

Product	Agricultural Inter-Cultivator	KisanKraft Invoice Date	
Brand	KisanKraft	KisanKraft Invoice No.	
Model	<input type="checkbox"/> KK-IC-406D <input type="checkbox"/> KK-IC-406D (Electric Start)		
WARRANTY PERIOD	6 MONTHS	FOR THE SPECIFIED PERIOD FROM THE DATE OF SALE OR DELIVERY WHICHEVER IS EARLIER.	
Dealer's Invoice Date		Dealer's Invoice No.	
Buyer's Info (Name, Address, Phone, etc.):		Dealer's Stamp (Address, Phone, TIN, etc.):	
Buyer's Sign		Dealer's Sign	

Warranty Policy

What is covered: KisanKraft Limited and its manufacturers warrant this product to be free from defects in material or workmanship. All parts defective in material and workmanship are covered.

This warranty will only cover defects arising under normal usage.

This warranty is limited to repair or replacement by KisanKraft Limited or its manufacturers of such parts as appear to KisanKraft or its manufacturers, upon inspection, to be defective in material and/or workmanship. KisanKraft or its manufacturers make no warranty with respect to items not manufactured or sold by them. No onsite warranty is provided by KisanKraft Limited or its manufacturers. Defective items must be brought/sent to our Authorized Dealer or KisanKraft Limited's office for service.

What is not covered: The *warranty shall become null and void* and neither KisanKraft Limited nor any of its manufacturers, nor its authorized dealers assume any responsibility, if the failure was caused by the following:

(1) Operation of product with incorrect fuel or lubricants, (2) Incorrect usage of machine or misuse, (3) Lack of maintenance, (4) Negligence, (5) Accident or physical damage, (6) Repairs made by unauthorized parties and/or with unauthorized parts, (7) Improper set up, adjustments, tampering or altered products (8) Any modification to the product what-so-ever.

Important: (1) Normal maintenance and adjustments to the product is the responsibility of the customer. (2) Normal wear and tear are not covered under warranty. (3) Rubber/plastic parts and consumables such as blades, clutch and clutch-bell, sparkplugs, nylon line, air-filters, fuel-filters, oil seals and gaskets etc. are not covered under the warranty. (4) Electrical Motor, Electrical Parts, Battery Etc. are not covered under the warranty.

Incidental / Consequential Loss: KisanKraft Limited or its manufacturers will not be liable for general damages, including bodily injuries, or for incidental or consequential damages

including, but not limited to, loss of use, loss of profits, loss of production, expense of substitute equipment or other commercial loss or damage.

Limitation of Liability: This limited warranty is in lieu of all other express warranties, obligations, or liabilities. Any implied warranties, obligations, or liabilities, including, but not limited to, any implied warranty of merchantability shall be limited in duration to the applicable warranty period. Any action for breach of any warranties hereunder, including, but not limited to, any implied warranty of merchantability must be brought within the applicable warranty period.

Modifications of Warranty: No agent, representative, dealer, or employee of KisanKraft Limited or any of its manufacturers has the authority to increase or alter the obligations of this warranty.

Assignment / Transfer of warranty: The warranty cannot be assigned and shall not transfer if the product is resold by the first buyer. The above warranties are extended to the first end user (original purchaser), and no warranty is made, nor authorized to be made assignable on resale by the first end user.

What you must do to obtain limited warranty service: To obtain performance of any obligation under this warranty for failure during the applicable warranty period, you must deliver the defective product, to the nearest Authorized Dealer, along with proof-of-purchase (invoice/receipt). KisanKraft Limited, its manufacturers and its dealers reserve the right to inspect the claimed defective part(s) to determine if the malfunction is the result of a defect covered by this warranty. Please note that the decision of KisanKraft Limited with respect to any warranty claim is final.

After-sales Service (Including Warranty): KisanKraft Limited does not sell directly to consumers. All sales or supplies are made through Authorized Dealers. It is the responsibility of the Authorized Dealer to provide all after-sales service to consumers. Any warranty claim should be raised by dealer to KisanKraft Limited as per warranty policy.

Jurisdiction: All disputes are subject to Bangalore court's jurisdiction.

Notes:

- This purchase is not contingent upon a product demonstration. The purchaser shall satisfy himself with the product, including any product demonstration or verification of any function, before buying. KisanKraft Limited or its authorized dealers, including online sellers, shall not be liable to give any on-site demonstration after purchase of any of the product.
- Any product once used will not be taken back by KisanKraft Limited.
- Warranty and After Sale Services (including but not limited to installation, Demonstration, Repair, Routine Maintenance etc.), should be done through the Authorized Dealer selling this product.
- Dealers should have their own technician to provide After Sales Services to their Customers. KisanKraft Limited provides free training to Authorized Dealer's technicians at KisanKraft Limited's head office, on request from Authorized Dealer.

User Manual



KisanKraft Limited

Warehouse: 818 3B1 to 818 3B18, Podalakur - Sangam Road, Prabagiripatnam, Podalakur, Nellore - 524345, Andhra Pradesh, INDIA

Head Office: Sri Huchhanna Tower, #4, 1st Main, 7-A Cross, Maruthi Layout, Dasarahalli, HAF Post, Hebbal, Bangalore 560024, Karnataka, INDIA

- ◆ Bangalore (HO) ◆ Ahmedabad ◆ Bhopal ◆ Bhubaneswar ◆ Coimbatore
- ◆ Guwahati ◆ Hubli ◆ Hyderabad ◆ Jaipur ◆ Karnal
- ◆ Kolkata ◆ Lucknow ◆ Nellore ◆ Pune ◆ Raipur



Scan the QR code to download
KisanKraft App

App is available on



Scan the QR code for
KisanKraft Youtube Channel



CONTENTS

Before Getting Started	7
Application	7
Safety Instructions	7
Overview	9
Scope.....	10
Assembly Instructions	11
Assembly drawing of safety protection guard installation.	12
Installation and Adjustment for cable:.....	12
Checks and Refueling:	14
Connection of Auxiliary Devices & Tools.....	15
Before Operating an Engine.....	17
Starting the Engine.....	17
Operation	18
Maintenance & Service	21
Troubleshooting.....	23
Technical Specifications	31
Parts Diagram & List- ENGINE	33
Parts Diagram - Gearbox	41

Product	Agricultural Inter-Cultivator	KisanKraft Invoice Date	
Brand	KisanKraft	KisanKraft Invoice No.	
Model	<input type="checkbox"/> KK-IC-406D <input type="checkbox"/> KK-IC-406D (Electric Start)		
WARRANTY PERIOD	6 MONTHS	FOR THE SPECIFIED PERIOD FROM THE DATE OF SALE OR DELIVERY WHICHEVER IS EARLIER.	
Dealer's Invoice Date		Dealer's Invoice No.	
Buyer's Info (Name, Address, Phone, etc.):		Dealer's Stamp (Address, Phone, TIN, etc.):	
Buyer's Sign		Dealer's Sign	

Warranty Policy

What is covered: KisanKraft Limited and its manufacturers warrant this product to be free from defects in material or workmanship. All parts defective in material and workmanship are covered.

This warranty will only cover defects arising under normal usage.

This warranty is limited to repair or replacement by KisanKraft Limited or its manufacturers of such parts as appear to KisanKraft or its manufacturers, upon inspection, to be defective in material and/or workmanship. KisanKraft or its manufacturers make no warranty with respect to items not manufactured or sold by them. No onsite warranty is provided by KisanKraft Limited or its manufacturers. Defective items must be brought/sent to our Authorized Dealer or KisanKraft Limited's office for service.

What is not covered: The *warranty shall become null and void* and neither KisanKraft Limited nor any of its manufacturers, nor its authorized dealers assume any responsibility, if the failure was caused by the following:

(1) Operation of product with incorrect fuel or lubricants, (2) Incorrect usage of machine or misuse, (3) Lack of maintenance, (4) Negligence, (5) Accident or physical damage, (6) Repairs made by unauthorized parties and/or with unauthorized parts, (7) Improper set up, adjustments, tampering or altered products (8) Any modification to the product whatsoever.

Important: (1) Normal maintenance and adjustments to the product is the responsibility of the customer. (2) Normal wear and tear are not covered under warranty. (3) Rubber/plastic parts and consumables such as blades, clutch and clutch-bell, sparkplugs, nylon line, air-filters, fuel-filters, oil seals and gaskets etc. are not covered under the warranty. (4) Electrical Motor, Electrical Parts, Battery Etc. are not covered under the warranty.

Incidental / Consequential Loss: KisanKraft Limited or its manufacturers will not be liable for general damages, including bodily injuries, or for incidental or consequential damages

This warranty is null & void, if you fail to register the warranty with KisanKraft by sending the KisanKraft Copy with dealer's stamp.

including, but not limited to, loss of use, loss of profits, loss of production, expense of substitute equipment or other commercial loss or damage.

Limitation of Liability: This limited warranty is in lieu of all other express warranties, obligations, or liabilities. Any implied warranties, obligations, or liabilities, including, but not limited to, any implied warranty of merchantability shall be limited in duration to the applicable warranty period. Any action for breach of any warranties hereunder, including, but not limited to, any implied warranty of merchantability must be brought within the applicable warranty period.

Modifications of Warranty: No agent, representative, dealer, or employee of KisanKraft Limited or any of its manufacturers has the authority to increase or alter the obligations of this warranty.

Assignment / Transfer of warranty: The warranty cannot be assigned and shall not transfer if the product is resold by the first buyer. The above warranties are extended to the first end user (original purchaser), and no warranty is made, nor authorized to be made assignable on resale by the first end user.

What you must do to obtain limited warranty service: To obtain performance of any obligation under this warranty for failure during the applicable warranty period, you must deliver the defective product, to the nearest Authorized Dealer, along with proof-of-purchase (invoice/receipt). KisanKraft Limited, its manufacturers and its dealers reserve the right to inspect the claimed defective part(s) to determine if the malfunction is the result of a defect covered by this warranty. Please note that the decision of KisanKraft Limited with respect to any warranty claim is final.

After-sales Service (Including Warranty): KisanKraft Limited does not sell directly to consumers. All sales or supplies are made through Authorized Dealers. It is the responsibility of the Authorized Dealer to provide all after-sales service to consumers. Any warranty claim should be raised by dealer to KisanKraft Limited as per warranty policy.

Jurisdiction: All disputes are subject to Bangalore court's jurisdiction.

Notes:

- This purchase is not contingent upon a product demonstration. The purchaser shall satisfy himself with the product, including any product demonstration or verification of any function, before buying. KisanKraft Limited or its authorized dealers, including online sellers, shall not be liable to give any on-site demonstration after purchase of any of the product.
- Any product once used will not be taken back by KisanKraft Limited.
- Warranty and After Sale Services (including but not limited to installation, Demonstration, Repair, Routine Maintenance etc.), should be done through the Authorized Dealer selling this product.
- Dealers should have their own technician to provide After Sales Services to their Customers. KisanKraft Limited provides free training to Authorized Dealer's technicians at KisanKraft Limited's head office, on request from Authorized Dealer.

This warranty is null & void, if you fail to register the warranty with KisanKraft by sending the KisanKraft Copy with dealer's stamp.

Before Getting Started

Thank you for purchasing our Inter-cultivator.

- This manual can guide you to solve the problems when you are installing, manipulating, and repairing the machine. With the continuous innovation and improvement of the products, the contents in the instruction manual may differ slightly from the actual situations, your understanding and pardon is highly appreciated. If you find some problems or have some good suggestions, please do not hesitate to contact your dealer.
- No part of this publication may be reproduced without written permission.
- This manual should be considered a permanent part of the intercultivator and remain with it if it is resold.

Application

This machine is small, lightweight, multi-functional, and with a high efficiency for Intercultural/Weeding Operations. It can climb hills, run in water, walk over the field ridges and ditches, move freely and change the directions easily, and it is especially applicable to various works in hilly area, dry land, paddy field, orchard, vegetable garden and greenhouse, etc. Intercultural/Weeding Operations, ditching & ridging, and transport are the machine's basic functions. Moreover, after being equipped with relative devices and tools, it may be used to pump water, spray water and pesticide, reap the crops, generate electricity, fertilizer, implant seeds, threshing, cut tendrils, grind something, etc. The machine has a simple structure, can be easily repaired and its fuel consumption is less. It is your ideal micro agricultural machine.

Safety Instructions

- Read the instructions carefully. Be familiar with the controls and the proper use of the equipment.
- Never allow children or people unfamiliar with these instructions to use the machine.
- Never work while people, especially children, or pets are nearby.
- Operator or owner is responsible for accidents or hazards to other people or their property.

Before starting the machine:

- Ensure sufficient engine oil.
- Press clutch during gear shifting.
- Load after idling the machine for 5 minutes.
- Close the choke for cold start
- Keep the choke half open for hot start.
- Before starting the machine, set shifting bar to the neutral position.
- When the machine is working, pay attention to the safety!
- Be careful not to be hurt by the rotary blades!
- While grasping the reverse handle, the shifting bar must be set to the neutral position.
- Fuel and lubricant must be clean.
- Clutch must be broken off when changing the shift.
- Please read the contents of nameplate on the handlebar carefully before using the machine.
- Must install the safety protecting board on the machine before using machine or after maintenance.

This warranty is null & void, if you fail to register the warranty with KisanKraft by sending the KisanKraft Copy with dealer's stamp.

- Muffler is a high temperature spare part, do not touch the Inter-cultivator in work or out of work freshly.
- When the Inter-cultivator is working, keep an eye on the rotary parts, do not be too close to the machine to avoid being hurt by the rotary blades.
- Keep the components of oil box away from fire and smoke.
- Keep this machine stable before use and read the instruction carefully
- Please refuel on time
- Please pay attention to warning signs

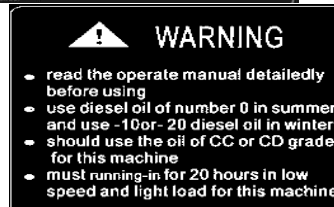
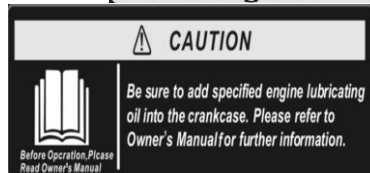
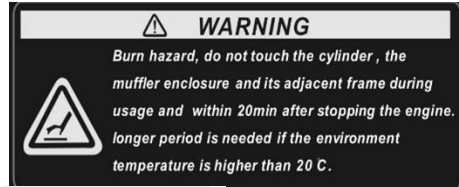

This warranty is null & void, if you fail to register the warranty with KisanKraft by sending the KisanKraft Copy with dealer's stamp.

Overview

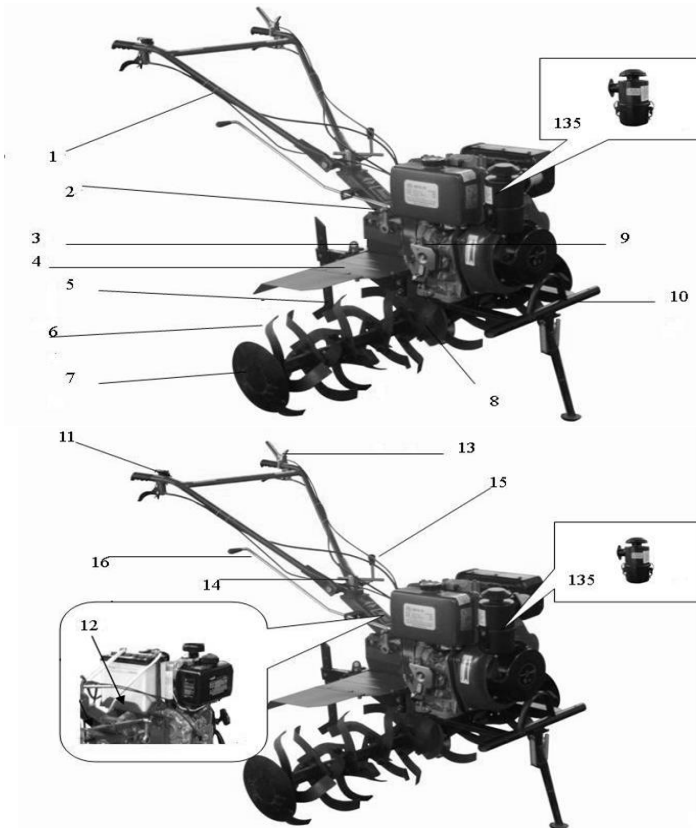

- | | |
|------------------------------------|-------------------------------------|
| 1. Handle Bar | 9. Diesel Engine |
| 2. Gearbox Assy. | 10. Bumper |
| 3. Adjustment Screw | 11. Throttle Switch |
| 4. Fender | 12. Battery base |
| 5. Deep Furrowing Resistance Stick | 13. Safety Device (Dead-man Handle) |
| 6. Rotary Blade | 14. Locked Handle (Up & Down) |
| 7. Side Disc | 15. Locked handle (left & right) |
| 8. Stepped Box Assy. | 16. Shifting Bar |

This warranty is null & void, if you fail to register the warranty with KisanKraft by sending the KisanKraft Copy with dealer's stamp.

Scope

Intercultural/Weeding Operations: Applicable to garden, tea plantation, orchard, sugarcane, corn land, vegetables land, greenhouse etc., for rotary assignments.

Fix the tines onto the left and right side of the transmission shaft of the running part of the Inter-cultivator, then use two M8x55 screw bolts for axial positioning. After that, the machine can start Intercultural/Weeding Operations. (See following table 2 and figures 2, 3)

Form of Tines	Four groups		Five groups	
	3 blades	4 blades	3 blades	4 blades
No. of blades	3x8	4x8	3x10	4x10
Width of Intercultural/Weeding Operations (mm)	1050	1050	1350	1350
Applicable Soil	Paddy field without too much water and with Earth of high moisture	Hard earth	Wet earth after rain	Dry land or with long stump from long-stem. Crop.

Figure 2. Inter-cultivator



Figure 3. Ditching device



Ditching & Ridging: Knock down the adjustment screw before the ditcher is fixed. Subject to the adjustment of the width and height for ditcher, the ditching can be conducted. (See figure 3)

Short Distance Transport: When fixing the forearm of the wagon box on the trailer and wheels on the transmission shaft of the running part, the machine can be used for transportation. The rated load is 250kg, under normal rotation speed of the diesel engine, speed of the fast shift is about 10km/h and that of the slow shift is about 5 km/h.

Multi-Functional Working: Dismount protection cover of the gearbox (No.2 in Figure 1), unscrew the bolts away from the rear part of the main shaft, and take the cover for keys out of the shaft, fasten the self-contained belt pulley or coupling onto the gearbox's main shaft's rear part with screws. Type A of common V belt is adopted for belt pulley's cross section. Rated rpm of the belt pulley is 3000 rpm. When the corresponding devices are equipped, pumping water, spraying, threshing, reaping, generating electricity, etc. are realized. (Above additional implements are in exploration process.)

This warranty is null & void, if you fail to register the warranty with KisanKraft by sending the KisanKraft Copy with dealer's stamp.

Assembly Instructions

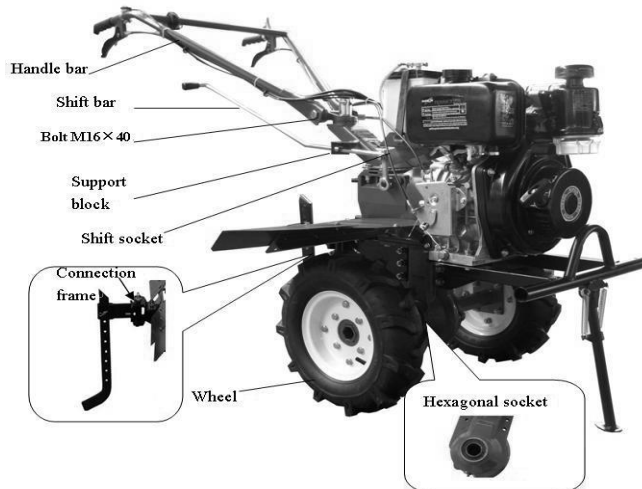

1. Fix the main machine; insert the hexagonal output shaft onto stepped box's output casing's hexagonal hole.
2. Fix the hexagonal stop casing onto the hexagonal output shaft with M6×6 socket head screws, and make sure the hexagonal shaft does not move axially.
3. **Wheel fixing:** fix the wheels at the two sides of the hexagonal output shaft and fix them with two M8×55 bolts and M8 nuts.
4. **Trailer fixing:** Fix the link group onto the trailer, use the link shaft assembly for connection, insert the split pin $\phi 3 \times 26$ and insert the velocity adjustment screw into square groove of the link group, and fix it with M8×55 bolts and nuts.
5. **Handlebar fixing:** Two gear discs of the handlebar support aim at the discs of the handlebar support base and adjust the positions. Fix them with M16×140 bolts, flat gasket 16 and spring gasket 16.
6. **Shifting bar assembly:** Get the shifting bar through the groove of shift support in the handlebar support base and insert it into the hole of the shift casing, then fix it with split pin $\phi 3.2 \times 16$. Set the shifting bar in neutral position.

Note: This picture shows **KK-IC-406D**. The output of the PTO shaft is connected to the gearbox of the Inter-cultivator. This feature results in improved engine performance

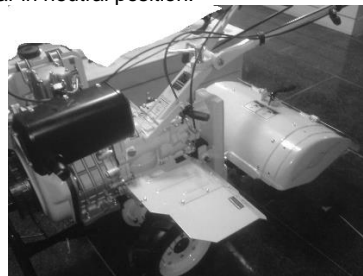

This warranty is null & void, if you fail to register the warranty with KisanKraft by sending the KisanKraft Copy with dealer's stamp.

Assembly drawing of safety protection guard installation.

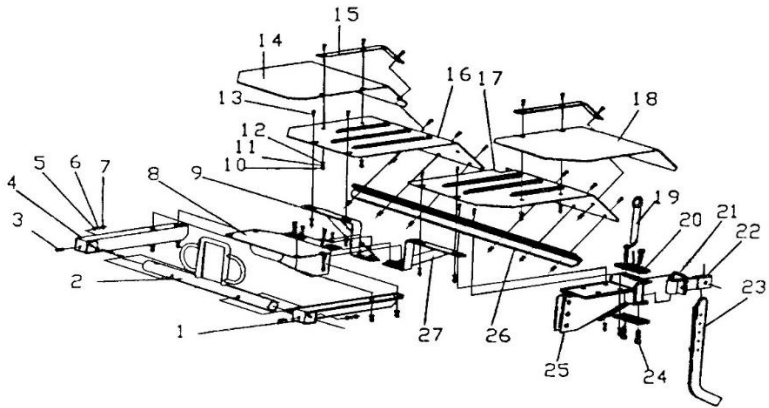

- | | |
|---|--------------------------------------|
| 1. Bracket of collision bumper(left) | 15. Fifty of safety protection guard |
| 2. Bracket of collision bumper(front) | 16. Safety protection guard(right) |
| 3. Bolt m8 (bg5781-86) | 17. Safety protection guard(left) |
| 4. Bracket of collision bumper(right) | 18. Fender for paddy field(left) |
| 5. Nut m8(gb41-86) | 19. Dowel |
| 6. Spring washer $\varnothing 8$ (gb93-87) | 20. Connecting plate |
| 7. Washer $\varnothing 8$ (gb95-85) | 21. Bolt m8x50(gb5781-86) |
| 8. Stand (diesel) | 22. Connector jointing assembly |
| 9. Bracket(right) | 23. Deep furrowing resistance stick |
| 10. Nut m6(gb41-86) | 24. Bolt m8x25(gb5781-86) |
| 11. Spring washer $\varnothing 6$ (gb93-87) | 25. Bulling set (trough comp 16mm) |
| 12. Washer $\varnothing 6$ (gb95-85) | 26. Bracket of fender comp |
| 13. Bolt m6x10(gb5781-86) | 27. Bracket (left) |
| 14. Fender for paddy field (right) | |

ATTENTION: After maintenance the safety protection guard installment must be fixed on the Inter-cultivator wholly.

Installation and Adjustment for cable:

(Please See Figure 5 and 6 below.)

1. Unscrew the locknut of the tie rod.
2. Spin the tie rod clockwise until the exposed handle support is the shortest.
3. Get the joint of cable into the clutch wire socket of rear part of the gearbox assembly and ensure the joint of cable goes into the hole of the socket.
4. Get the wire into the M8 hole on base of the clutch fork arm, properly press the fork arm of the clutch, and put the joint of cable into the wire socket.
5. Unscrew the tie rod, grasp and loosen the clutch handle until the spring force in the clutch can reset the handle, then screw the locknut.

Figure 5

This warranty is null & void, if you fail to register the warranty with KisanKraft by sending the KisanKraft Copy with dealer's stamp.

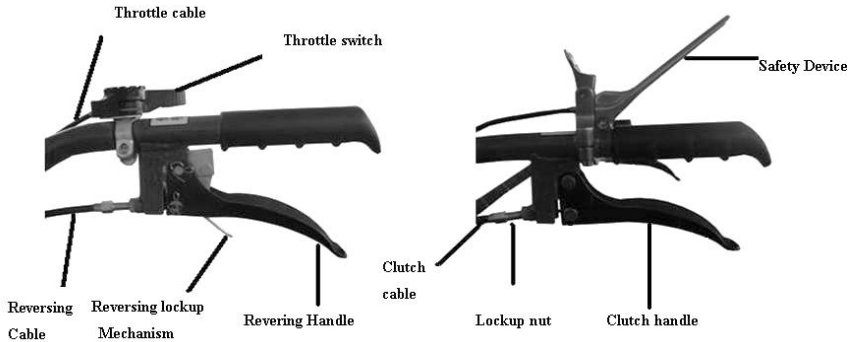
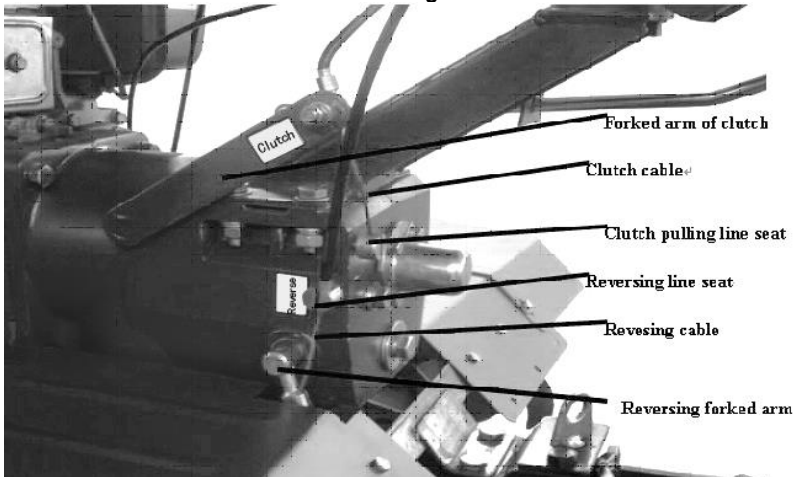

Figure 6



Adjustment of the reversing gear cable: (See Figure 5 and 6)

1. Unscrew the locknut of the tie rod.
2. Spin the tie rod clockwise until the bare handle support is the shortest.
3. Get the cable into the reversing fork shaft besides the gearbox and ensure the joint of cable goes into the hole of the fork shaft.
4. Properly pull the reversing fork shaft counterclockwise, get the cable into the narrow gap of the reversing wire socket besides the gearbox, and ensure the pipe head goes into the hole of the wire socket.
5. Unscrew the tie rod, grasp and loosen the clutch handle until the spring force in the clutch can reset the handle, then screw the locknut.

This warranty is null & void, if you fail to register the warranty with KisanKraft by sending the KisanKraft Copy with dealer's stamp.

Adjustment of the throttle cable: (See Figure 7)

- Shift the throttle switch clockwise to minimum positioning.
- Get wire of the throttle cable into the threading base and firm base on
- Top of the throttle adjustment board of the diesel engine.
- Tighten the wire, screw the binding bolts on the firm base.
- Adjust the throttle switch repeatedly until the throttle handle on the oil valve adjustment board can reach the maximum and minimum position.

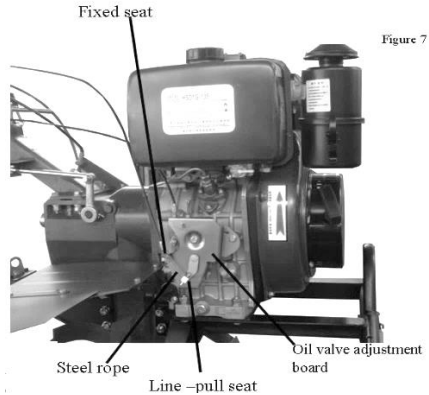

Checks and Refueling:

1. Check whether all the connection bolts are tight or not, and fix the connection bolts according to the moment of force listed in table 3. (Refer to the instruction manual for diesel engine for the screwing moment of force bolt and nut respectively)

Name of parts	Moment of force (N.M)
Flange and the diesel engine	20-25
Flange and the gearbox	35-40
Binding bolts of end of driving shaft of gearbox	10-12
Binding bolts of reversing gear shaft of gearbox	26-40
Binding bolts between engine support and traveling mechanism	35-40
Binding bolts of cover of the traveling mechanism	10.6-15
Binding bolts of trailer of the traveling mechanism	50-60
Connection bolts between traveling mechanism and gearbox	35-40
Trailer unit	45-60
Set bolts of the diesel engine base	35-40
Set bolts of the handle support base	35-40

2. Check each handle of the manipulation system (throttle switch, clutch, shifting bar and reversing bar) to see whether they can move freely or not. If they are out of the right positions, make them at the right positions.
3. Pull shift bar of the gearbox to the neutral position.
4. Refilling the engine oil:
 - Refill the SAE10W-40 lubricant into the crankcase of
 - The diesel engine. See Figure 9 for details Make the whole machine stable and horizontal, and refilling 20 # lubricant engine oil into the gearbox from oil hole at the top of the gearbox. when check the oil level, put the oil dipstick into the oil. (Note: not to turn the dipstick around), the oil level should be between the two limits of the oil dipstick. (Refer to figure 8)

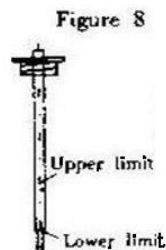

This warranty is null & void, if you fail to register the warranty with KisanKraft by sending the KisanKraft Copy with dealer's stamp.

Select the appropriate lubricant for the diesel engine according to the environmental temperature. (See figure 9).

Fill in machine oil when diesel engine is placed level, and checking the oil level only needs a poke by dipstick rather than a rotation of dipstick.

Lubricant Oil grade shall be grade CC or CD.

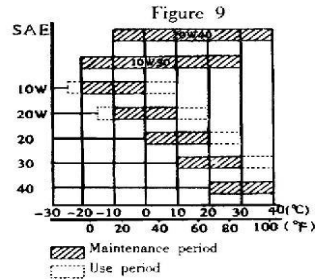
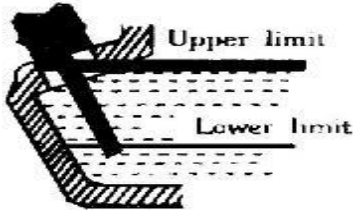

5. Knock down the lower cover of the air cleaner, refill about 0.1 liter 20# engine oil into the air cleaner.

Important Note: Do not exceed the mark when refilling.

Connection of Auxiliary Devices & Tools

1. **When Intercultural/Weeding Operations is needed:** Knock down the wheels, fix the hexagonal union of the Inter-cultivator onto two ends of the hexagonal shaft of the running part, and axially fix them with M8x55 bolt. Note: Intercultural/Weeding Operations blades are divided into two groups, namely, the left and the right. Fixing the blades should guarantee that when the machine is running, the blade edge should work first. After fixing the blades, also fix the left and right protection board for safety purpose. Depth of the Intercultural/Weeding Operations can be realized by adjusting height of the velocity adjustment screw and angles between the lever and the ground (refer to table 4).
2. **Intercultural/Weeding Operations of paddy field:** When the submerged depth of human's feet in the paddy field is less than 25cm, bent blades for wet land can be directly used for the Intercultural/Weeding Operations of paddy field.
3. **When ditching is needed:** Unlade the Deep Furrowing Resistance Stick, fix the ditcher, adjust width & height of the ditcher, and then ditching can be conducted.
 - Width scope of ditching: 14cm-40cm
 - Depth scope of ditching: 11cm-25cm
4. **Short distance transport:** Fix forearm of the wagon box on the trailer and wheels on the transmission shaft of the running part, the machine can do a transportation job. The rated load is 250kg, under normal rotated speed of the diesel engine, speed of the fast shift is about 10 km/h and that of the slow shift is about 5km/h.
5. **Multi-functional working:** Knock down protection over of the gearbox (No.2 in Figure 1), unscrew the bolts away from the rear part of the main shaft, and take the cover for keys out of the shaft. Fasten the self-contained belt pulley or coupling onto the gearbox's main shaft's rear part with screws. Type



Hookup, Electric Starter:

This warranty is null & void, if you fail to register the warranty with KisanKraft by sending the KisanKraft Copy with dealer's stamp.

A of common V belt is adopted for belt pulley's cross section. Rated rpm of the belt pulley is 3000 rpm. When the corresponding devices are equipped, pumping water, spraying, threshing, reaping, generating electricity, etc. are realized.

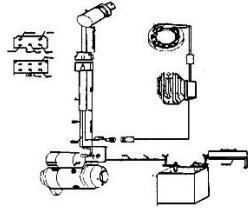

Preparation:

1. The safety protection guard must be attached to the machine before using.
2. Check that the blade and fender are correctly assembled and securely fastened.
3. While working, always wear substantial footwear and long trousers. Do not operate the equipment barefoot or wearing open sandals.
4. Thoroughly inspect the area where the equipment is to be used and remove all objects which can be thrown out by the machine.
5. **WARNING**-Diesel is highly flammable:
 - a. Store fuel in containers specifically designed for this purpose
 - b. Refuel outdoor only and do not smoke while refueling.
 - c. Add fuel before starting the engine. Never remove the cap of the fuel tank or add diesel while the engine is running or when the engine is hot.
 - d. If diesel is spilled, do not attempt to start the engine but move the machine away from the area of spillage and avoid creating any source of ignition until diesel vapors have dissipated.
 - e. Replace all fuel tank and container caps securely
6. Replace faulty silencers
7. Before using, always visually inspect to see that tools are not worn or damaged. Replace worn or damaged elements and bolts in sets to preserve balance.

This warranty is null & void, if you fail to register the warranty with KisanKraft by sending the KisanKraft Copy with dealer's stamp.

Before Operating an Engine

Break-in of new engine:

- Refer to the Engine's instruction manual for the breaking-in of the diesel engine
- As for a new or overhauled Inter-cultivator, it should be working for 1 hour under no load or 5 hours under light load, then drain all the lubricant from the gearbox and crankcase of the diesel engine, refill appropriate fix of clean diesel, and clean them at a slow speed for 3-5 minutes, then drain the diesel off. Refill engine oil into them according to instructions to enter four hours breaking-in, then the machine can work.
- If your engine is not breaking in yet, improper usage will shorten the life of engine. The initial 20 hrs. is the break-in-period. The operator must obey the following rules:

Running in for 5 minutes after first start: Running with low speed and low load before the engine gets hot. Avoid running with high speed and full load, or low speed and no load.

Avoid running with overload: During break-in period, the engine can't run with full load, but can run with 3000rpm and 50% load.

Change engine oil regularly: After working for 20hrs, change the oil when engine is still warm, otherwise it will be difficult to drain the residual oil in the engine.

Oil Bath Type Air Filter:

- Check the oil level before operating.
- Fill oil up to upper limit. If oil is dirty, change it. Please use diesel to clean oil bath element frequently, then dip the element in the oil and squeeze out extra.

Starting the Engine

Note: The shift bar must be in the neutral position

1. Start the diesel engine according to the procedures stipulated in the instruction manual for the diesel engine.
2. The diesel engine should run at a low speed (1500-2000 rpm) under no load for 2-3 minutes.
3. Check whether the diesel engine runs normally or not. If it is abnormal, stop the engine and have a check.

Warning:

- Be sure to operate the engine in a good, ventilated place in order to avoid exhaust poisoning.
- Avoid letting hands, body & clothes entangle in output shaft, belt pulley, V-type belt pulley and other moving parts, so as to prevent from getting injury.
- Stop the engine first and then maintain the movable parts and other parts around it. Make sure there are no tools and sundries in the body of the engine before operating.

Run engine for 5mins to warm up

Note:

- The muffler becomes very hot during and immediately after operation. Don't touch it.
- The air filter will inhale the air around itself when the engine works.
- Don't let the hands, body and clothes approach the air filter to avoid injury.

After the engine becomes warm, put the speed lever on necessary position to run the engine.

Note:

- Be sure to use the speed lever to adjust the speed of engine.
- Do not loosen the speed limit screw and fuel control screw; otherwise, the speed and output of engine will be abnormal.

While the engine is running

This warranty is null & void, if you fail to register the warranty with KisanKraft by sending the KisanKraft Copy with dealer's stamp.

- If the engine gives out black smoke continuously, it is because the engine is overloaded. The belt pulley of the engine or that of the powered equipment must be adjusted.
- Pay attention to the following points when the engine is running:
 - i. Whether there is abnormal sound and vibration?
 - ii. Whether the exhaust is normal?
 - iii. Whether the engine gives out white or black smoke continuously?

If any of the above phenomena is detected, stop the engine immediately and contact the nearby dealer.

Methods of Starting the Agricultural Inter-cultivator

Starting by Hand:

1. Open fuel switch.
2. Put engine speed lever in the start position
3. Lock Auto-cut off switch.
4. Hold recoil starter handle.
5. Pull the starting handle slowly until you feel the resistance, then release it slowly.
6. Push the decompression lever down by hand to no compression position. It will get back automatically by itself after the engine gets started.
7. Starting: hold the starting handle with two hands, pull the rope lightly until you feel the resistance, then pull the rope fast with strength.
8. If it is not easy to start the engine when the weather gets cold.

You could take down the refuel screw on the cylinder cover and fill in 2ml oil before starting.

Note: Tighten the refuel screw on the cylinder cover except filling oil in order to avoid rain and dust from getting into the engine and wearing causing damage to the engine.

Operation

(Note: breaking-in must be performed before the using the Inter-cultivator)

1. Using a slow shift:
 - The left hand should grasp the clutch handle tightly making the clutch separated.
 - The right hand should pull the shift bar backwards, make sure the shift casing is in the slow shift position, and observe whether it reaches the right position or not. Then the right hand should grasp the right handle.
(Note: Do not grasp the reversing bar)
 - i. Loosen the clutch handle gradually, the clutch will combine, and the Inter-cultivator can run at a slow speed.
 - ii. The right hand should increase the throttle properly so that the motor can run at a speed of 5 km/h
2. Using a fast shift:
 - The left hand should grasp the clutch handle tightly making the clutch separated.
 - The right hand pushes the shift bar forwards, make sure the shift casing is located in the fast shift position, and observe whether it reaches the right position or not. Then the right hand should grasp the right handle.
(Note: Do not grasp the reversing bar)
 - Loosen the clutch handle gradually, the clutch will combine, and the Inter-cultivator can run at a fast speed.
 - The right hand should increase the throttle properly so that the motor can run at a speed of 10 km/h.
3. Using a reversing shift:
 - The left hand should grasp the clutch handle tightly making the clutch separated.

This warranty is null & void, if you fail to register the warranty with KisanKraft by sending the KisanKraft Copy with dealer's stamp.

- The right hand should pull or push the shift bar to the neutral shift and observe whether it reaches the right position or not. The fore finger of right hand should grasp the trigger of the reversing shift first, then the right hand should grasp the reversing handle.
 - Loosen the clutch handle gradually, the clutch will combine, and the Inter-cultivator can run backwards.
(Note: Do not loosen the reversing handle)
 - When the backward running of the machine is not needed, the left hand should hold the clutch handle gradually, and the right hand should loosen the reversing handle.
4. **Shift:**
When the machine is running, reduce the oil valve of the diesel engine (but subject to the diesel engine's not quenching), then the clutch is made separated. When the machine stops running, then shift.
5. **Change directions:**
Pull the handle to left or right to make the machine turn left or right.
(Note: pulling the wrong handle may damage the gears)
6. **The operation method of recoil/electric starter and safety device:**
- Left hand close upon the red emergency stop lever in the handlebar; draw back the clutch handle with your middle finger and ring finger at a time. The above mutual locking will make the engine ready to start. And now, the operator can recoil –start the engine with hand according to the instructions given in the manual.
 - If the engine is of electric-starting model, carry out the following two steps. (step2, 3 are not suitable for recoil start engine) connecting well the power supply and control switch as the electric start hookup (or connect it beforehand). If the Inter-cultivator is without power supply, you should prepare a lead-acid battery accord with direct current 12V, 36AH.
 - Turn the starting-key Clockwise to the start position after inspecting clearly, and then release the key after the engine has started, it will return to the primary position automatically.
 - Adjust the throttling cock to the right position after the engine has started.
 - Press the red emergency lever in the handlebar (Grasp the emergency stop handle and the handlebar with your left hand) and buckle the trigger of emergency stop lock come out from the clutch handle gently by your middle finger. Restore the clutch handle down, then the clutch switch on, and the machine start to work. You should grasp the emergency stop handle and handlebar all the while in whole working course.
 - In case of any emergency, release the emergency stop handle and handlebar, the engine will flameout and the machine will stop working immediately.
7. **Stopping the machine:**
- Grasp the clutch handle, and separate the clutch.
 - Pull the shift bar to the neutral position, loosen the clutch handle, and turn the oil switch clockwise to the minimum position, now the machine will stop.
 - When stopping of the diesel engine is needed, it should be conducted according to relative contents in the instruction manual.
(Note: Stopping the machine is generally conducted on the flat ground)

Safety Instructions during operation:

DO'S

- Do visual check every time before starting,
- Keep Agricultural Inter-Cultivator Clean

This warranty is null & void, if you fail to register the warranty with KisanKraft by sending the KisanKraft Copy with dealer's stamp.

- Do use recommended Fuel and Lubricants only
- Do check the fuel level
- Do check air intake filter oil level
- Do check engine oil and gear oil levels
- Do check for any leakage
- Do check decompress knob before starting
- Do check if the gear is in neutral position before starting
- Do use recommended attachments only
- Do maintain distance (1ft) from buildings and other equipment's when operating, to avoid any accidents
- Keep the machine away from flammable materials
- Keep the machine away from children and pets to avoid any injuries or accidents.
- Only operator with knowledge of machine and its operations must be permitted to operate Agricultural Inter-Cultivator
- Must stop the engine before refueling, and refuel in a place with good ventilation.
- Must clean and spilled or over flown fuel of the Agricultural Inter-cultivator
- Let Agricultural Inter-Cultivator cool down before storing indoors.
- Work only in daylight or in good artificial light.
- Always be sure of your footing on slopes
- Walk, never run with the machine.
- Exercise extreme caution when changing direction on slopes
- Use extreme caution when reversing or pulling the machine towards you
- Start the engine carefully according to instructions and with feet well away from the tool(s).
- Never pick up or carry a machine while the engine is running
- Stop the engine:
 - Whenever you leave the machine
 - Before refueling
 - Reduce the throttle setting during engine shut down and, if the engine is provided with a shut-off valve, turn the fuel off at the conclusion of working

DON'TS...

- Don't overfill the tank with fuel, but also never let fuel tank run out empty
- Don't use adulterated fuel
- Do not work on excessively steep slopes
- Do not change the engine governor setting or over speed the engine
- Do not put hands or feet near or under rotating parts.
- Don't smoke or allow flame or spark where Agricultural Inter-cultivator is refueled or where fuel is stored
- Don't inhale exhaust for it can contain poisonous carbon monoxide
- Don't run Agricultural Inter-cultivator in a place without adequate ventilation
- Don't lean/tilt Diesel tank more than 20°, otherwise fuel may spill
- Don't cover Agricultural Inter-cultivator top so as to avoid fire
- Don't touch muffler/exhaust, as it gets hot during operating and stays hot for some time even after stopping
- Don't delay on service schedules
- Don't Operate Diesel Hal continuously more than 2hrs.30mins for any given operation (Give a break of 20mins)

This warranty is null & void, if you fail to register the warranty with KisanKraft by sending the KisanKraft Copy with dealer's stamp.

- Don't make any alterations in Design, Operations and Functioning of Agricultural Inter-cultivator other than Company's recommendation
- Do not operate the engine in a confined space where dangerous carbon monoxide fumes can collect.

Important Cautions during Operation

1. Pay attention to working situations and sound of each part during the work, check whether the connection between different parts is ok or not, loose connections are not allowed. If abnormalities are found, stop the machine and solve the problem immediately.
2. A cold machine should not be used to do heavy load work immediately after the machine is started, especially for the new machines or the ones after overhaul.
3. Pay attention to checking the oil levels of the diesel engine and gearbox. Refill the engine oil when it is not enough
4. Do not cool the diesel engine by pouring water.
5. Be cautious about the machine's tilting while farming.
6. Machine fixed with Intercultural/Weeding Operations blades should not be used on sandy or stony place.
7. After using the machine for farming, pay attention to cleaning dirt, weeds and smear on the surface of the machine and keep the machine clean.
8. Clean the air cleaner with sponge or the wire mesh frequently, and change the engine oil. (Keep an eye on the marking on the empty air cleaner oil level)

Maintenance & Service

During the working period of the Inter-cultivator, due to the changing running speeds, abrasion and varying loads, phenomena of bolts loosening and parts wearing are inevitable which in turn may lead to the malfunction of the system, abnormalities of clearances, declination of engine power, more oil consumption, malfunction of each part, more failures of the machine, and the problems affect the normal use of the Inter-cultivator. To reduce chances of troubles, it is better to do a strict and regular maintenance job which emphasizes precautionary measures to keep a good performance and extend the machine's working life.

1. Keep all nuts, bolts and screw tight to ensure the equipment is in safe working condition.
2. Never store the equipment with diesel in the tank inside a building where fumes can reach an open flame or spark.
3. Allow the engine to cool before storing in any enclosed place.
4. To reduce the fire hazard, keep the engine, muffler, battery compartment and diesel storage area free of inflammable material and excessive grease.
5. Replace worn or damaged parts for safety.
6. If the fuel tank has to be drained, this shall be done outdoors
7. After adjustment or maintenance, the safety protection guard must be attached to the machine.

Technical Service of Intercultivator

1. MAINTENANCE AFTER EACH WORK SHIFT (conducted before and after each shift)
 - Listen and observe if there are any abnormalities of each part (such as abnormal sound, overheating and bolt loosening)
 - Check if there is oil leakage in diesel engine, gearbox and Traveling box.

This warranty is null & void, if you fail to register the warranty with KisanKraft by sending the KisanKraft Copy with dealer's stamp.

- Check if the oil levels of the diesel engine and gearbox are between the two extremes of the dipstick.
 - Timely clean the mud, weeds and smear on the machine and its parts.
 - Keep a good record.
2. **FIRST LEVEL SERVICE (EVERY 150 WORKING HOURS)**
 - Do all the things listed for each work shift maintenance.
 - Clean the gearbox and Traveling box and change the engine oil.
 - Check and adjust the clutch, shift system and reversing gear system.
 3. **SECOND LEVEL SERVICE (EVERY 600 WORKING HOURS)**
 - Do all the things listed every 150 hours for service.
 - Check all the gears and bearing, replace with new ones if serious abrasion is found.
 - Other parts of the Inter-cultivator, like Intercultural/Weeding Operations blade or connection bolts. if damaged, replace with new ones.
 4. **TECHNICAL OVERHAUL (EVERY 1800-2000 WORKING HOURS)**
 - Take the machine apart in the local special service center, clean and check the machine, then replace or repair the seriously- worn out parts.
 - Specialized service men are invited to check the friction piece and clutch.
 5. **MAINTENANCE OF DIESEL ENGINE:**
 - Refer to the instruction manual of the diesel engine

Technical Service List of Intercultivator

Interval →→	Daily	8-Hrs	20-Hrs Or 1-Month	150-Hrs Or 3- Months	1000 Hrs Or 1-Year	2000 Hrs Or 2-Years
Check and screw bolts and nuts	✓					
Check and refill engine oil	✓					
Clean and change the diesel		✓	✓	✓		
Check oil leakage	✓					
Clean dirt, weeds and smear	✓					
Troubleshooting	✓					
Adjust the control parts	✓					
Friction piece of the clutch						✓
Gears and bearings					✓	

Note: The mark ✓ means service required.

Long-Term Storage of Inter-cultivator

When the Inter-cultivator needs a long-term storage, the following measures should be adopted to avoid rust.

1. The instruction manual of diesel engine requires sealing the diesel engine up for keeping purpose.
2. Clean dust and dirt away from the surface of the machine.

This warranty is null & void, if you fail to register the warranty with KisanKraft by sending the KisanKraft Copy with dealer's stamp.

3. Drain the lubricant from the gearbox and add new lubricant into it.
4. Paint anti-rust oil on the non-painted area of the non-aluminum surface
5. The machine should be kept in a well-ventilated, dry and soft place.
6. Keep well the self-contained tools, conformity certificate of product and instruction manual

Troubleshooting

Troubleshooting of Reversing Gears and Cables:

When the Inter-cultivator's running backwards is not normal, it is necessary to adjust the reversing gears and Cables, see the instructions below.

1. Grasp and loosen the reversing handle for 2-3 minutes to confirm the putting into gear. If it is abnormal, adjust it until it is qualified.
2. When the Inter-cultivator is running, loosen the reversing handle, the reversing gears should return to its original position and ensure that there is no abnormal sound made by gears colliding in the gearbox, otherwise, it may cause damage to the gear.

Troubleshooting of Clutch Cables:

After some time, use, the clutch does not perform well any more due to the weariness of friction piece and fork of clutch. As for how to adjust cable of the clutch, refer to instructions below.

1. Grasp and loosen the clutch handle for 2-3 times to confirm the clutch status. If abnormal, readjust it.
2. If repeated adjustment cannot solve the problem, excess abrasion of fork or friction piece of the clutch can be confirmed. The machine should be sent to special service center for replacing with a new fork of friction piece of the clutch.
3. Dismounting the clutch by unspecialized person, which may cause damage to the clutch and the machine is forbidden.

Troubleshooting of Accelerator Cables:

When spinning the throttle switch, check if the acceleration or deceleration performance of the diesel engine is good or not, adjust the throttle switch if necessary. Refer to instructions for measures.

1. Repeatedly spin the throttle switch for 2-3 times and confirm whether the acceleration or deceleration performance of the diesel engine is ok.
2. Joint of the cable must be firmly connected to the throttle cable.

Use & troubleshooting of Handlebar Frame:

According to your height, farming and other special requirements, the handlebar connection can be adjusted up and down, left and right appropriately as following: (see figure below)

This warranty is null & void, if you fail to register the warranty with KisanKraft by sending the KisanKraft Copy with dealer's stamp.

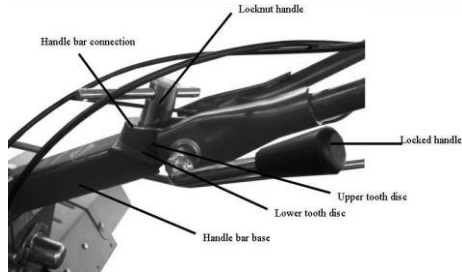

1. The up and down debugging for the handlebar connection
 - a) Unscrew the Locked handle of the handlebar connection and make the terminal tooth between the handlebar connection and the handlebar base separated.
 - b) Select the best position for the handlebar connection according to your height and comfort.
 - c) Then spin the handle to make the terminal teeth between the handlebar connection and handlebar base engage well with each other.
2. The left and right debugging for the handlebar connection.
 - a) Unscrew the locknut handle of the handlebar base and the upper and lower terminal teeth.
 - b) Spin the handlebar left or right to the desired position.
 - c) Then screw the locknut handle to make the higher and lower terminal teeth of the handlebar base engage well with each other.

Troubleshooting of Clutch:

NOTE: Please do not dismantle the clutch assembly yourself. You should contact our dealers for such repairs

Symptom	Cause	Remedy
Clutch fails	Failure of the clutch handle	Repair or replace the clutch handle
	Damage of the clutch Cables	Replace the clutch cables
	Fork not in the right position	Re-adjust the cable or replace the fork
	Welding points between fork shaft and arm base break off	Repair or replace the clutch cables
	Fork pin is bent or broken	Replace the fork pin
	Malfuction of the friction piece	Replace the friction piece
	Malfuction of spring	Replace the spring
	The friction piece fails to touch the bearing face of the clutch cover	Add some adjustment pads to the back of the bearing
Bearing is burnt in the clutch	Replace the bearing Pay attention to refilling engine oil into the gearbox	
Skidding/Slipping	The spring does not function due to tiredness	Replace the spring

This warranty is null & void, if you fail to register the warranty with KisanKraft by sending the KisanKraft Copy with dealer's stamp.

Symptom	Cause	Remedy
(After loosening the clutch, the diesel engine runs normally, but the main shaft of the transmission shaft stops running or runs slowly)	Fork shaft's failure to turn around freely makes the fork fail to reset completely	Clean the combined face between positioning shaft and pushing plate to make the fork move freely.
	Cable adjustment is not right	Re-adjust the clutch Cables.

Troubleshooting of Gearbox:

Symptom	Cause	Remedy
Failure of fast, slow and neutral shift	Bolts and nuts for the main shaft are loose	Dismount the bolts, keys cover at the back of the main shaft, screw the round nuts tight, then fix back the bolts and keys cover and screw them tight.
Failure to shift to the right position	Excess abrasion of puller	Replace the puller
	Driving angle gear is loose	Tighten the round nuts
	Excess abrasion of the upper hole in the connection piece of support arm	Replace the support arm assembly
	Positioning spring inside the main shaft does not function	Replace the shaft
	Main shaft is moving, the bolts for tightening the cover for the rear of the gearbox body are loose.	Screw the bolts tight
	Deformation of shift bar brings about interference when you shift	Adjust the shift bar or replace it
Failure to shift the reversing shift to the right position	Abrasion of reversing fork	Re-adjust the cable of reversing shift Replace the reversing fork
	Malfunction of reversing cable	Re-adjust the cable Replace the cable
	The reversing shaft is loose	Screw the bolts tight at the back of the reversing shaft
	The reversing fork is blocked to a standstill	Clean the combined face between reversing fork and reversing pushing plate to make the fork move freely
The reversing gears do not reset	The loosening of reversing shaft makes the gear be blocked to a standstill	Screw the bolts tight at the back of the reversing shaft.

This warranty is null & void, if you fail to register the warranty with KisanKraft by sending the KisanKraft Copy with dealer's stamp.

Symptom	Cause	Remedy
	Malfuction of spring of the reversing shaft	Replace the spring
	The reversing shaft is bent and deformed	Replace the reversing shaft
The reversing shaft is loose	Rear bolts of reversing shaft are loose	Screw the reversing shaft
	The matching between reversing shaft and gearbox body is too loose	Replace the shaft
Too much noise from the gears	Deformation and bend of the angle gear and reversing shaft	Replace the shaft
	Too much lateral clearance due to excess abrasion of gears	Replace the gears
	The matching between bevel gear and reversing shaft and gearbox body is too loose	Replace the shaft
Oil leakage of the main shaft's rear cover	Malfuction of O-shaped ring for the main shaft	Replace with O-shaped ring $\phi 17 \times 1.8$
	Malfuction of lip-shaped oil seal in the main shaft	Replace with lip-shaped oil seal B25407
	Malfuction of O-shaped ring for the cover	Replace with O-shaped ring $\phi 46 \times 1.8$
Oil leakage of the reversing shaft	Loosening of bolts at the back of reversing shaft	Screw the bolts tight
	Malfuction of O-shaped ring of the reversing shaft	Replace with O-shaped ring $\phi 18 \times 1.8$
Oil leakage of the fork shaft of the reversing shaft	Malfuction of O-shaped ring	Replace with O-shaped ring $\phi 1.2 \times 1.8$
Oil leakage of the fork shaft of the clutch	Malfuction of O-shaped ring	Replace with O-shaped ring $\phi 1.2 \times 1.8$
Oil leakage of the shift shaft	Malfuction of O-shaped ring	Replace with O-shaped ring $\phi 1.2 \times 1.8$
Oil leakage of the flange connection	The bolts are loose there	Screw the bolts tight
	The vulcanized paper board is damaged there	Replace the paper board
Leakage of the gearbox body	The gearbox body has tiny hidden holes	Re-welding or brush base paint to stop the leaking
Oil leakage of the fork shaft of the clutch	Malfuction of O-shaped ring	Replace with O-shaped ring $\phi 1.2 \times 1.8$
Oil leakage of the shift shaft	Malfuction of O-shaped ring	Replace with O-shaped ring $\phi 1.2 \times 1.8$
Oil leakage of the flange connection	The bolts are loose there	Screw the bolts tight
	The vulcanized paper is damaged	Replace the paper board

This warranty is null & void, if you fail to register the warranty with KisanKraft by sending the KisanKraft Copy with dealer's stamp.

Symptom	Cause	Remedy
Leakage of the gearbox body	The gearbox body has tiny hidden holes	Re-welding or brush base paint to stop the leaking

Troubleshooting of Traveling Mechanism

Symptom	Cause	Remedy
Too much noise from the gear	Excess abrasion or error repairing of the gear	Re-fix and re-adjust or replace the gear
Gears are blocked to standstill when running	Error in fixing	Re-fix the gears.
Overheating	Not enough lubricant in the box	Re-fill oil according to the request
	The lateral clearance of gear is too small	Re-fix
	The axial clearance is too small	Re-adjust the clearance value
Oil leakage of the gearbox connection	The connection bolt is loose	Screw the bolt tight
	The seal gasket is damaged	Replace with lip-shaped oil seal B45628
The oil leakage of the output shaft casing	The lip-shaped oil seal there is damaged	Replace with lip-shaped oil seal B45628
Serious oil leakage of the hexagonal hole in the output shaft casing	The shaft casing there is broken	Replace the shaft
Oil leakage of oil hole	The O-shaped ring there is damaged	Replace with O-shaped ring $\phi 10 \times 1.8$
	The bolts are loose	Screw the bolts tight
Leakage of the Traveling box body	The Traveling box body has tiny hidden holes	Re-welding or brush base paint to stop the leaking

Troubleshooting Bevel Gears Mesh:

When the abnormal transmission of mesh of bevel gear of sound is confirmed, stop the machine and check as follows:

This warranty is null & void, if you fail to register the warranty with KisanKraft by sending the KisanKraft Copy with dealer's stamp.

1. Clearance adjustment of mesh of angel gear in gearbox (See Figure 10)

- a) When lateral clearance of mesh of the gear $\Delta < 0.05\text{mm}$, we should put some vulcanized paper to enlarge the clearance between the gearbox and the traveling box.
- b) When lateral clearance of mesh of the gear $\Delta > 0.3\text{mm}$, we should reduce the clearance to 0.05-0.10 mm between the bearings and gear II shaft

2. Clearance adjustment of mesh of the gear in the running case. (See Figure 11)

- a) When lateral clearance of mesh of the gear $\Delta < 0.05\text{mm}$, we should increase adjustment pad I by 0.2-0.3mm to enlarge the clearance, and change vulcanized paper board II and adjustment pad. To ensure the axial clearance of the gear is 0.05-0.15mm.
- b) When lateral clearance of mesh of the gear $\Delta > 0.3\text{mm}$, we should reduce adjustment pad I, meanwhile the axial clearance of gear II is 0.05-0.15mm, or increase the adjustment pad II, meanwhile ensure the axial clearance of gear I is 0.05-0.15mm.

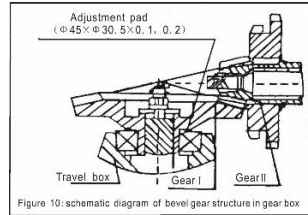

Figure 10: schematic diagram of bevel gear structure in gear box

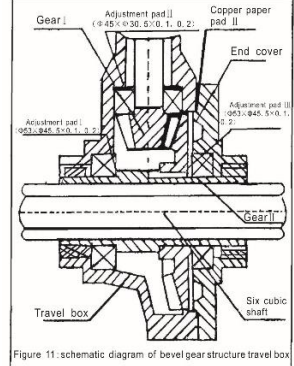

Figure 11: schematic diagram of bevel gear structure travel box

Engine Troubleshooting:

Difficulty in starting or failure to start:

Cause	Remedy
A. Extremely cold weather	Pour in 3-5g engine oil in air intake pipe or spray hot water at the top of the cylinder head.
B. Failure of fuel system	
1. Fuel is frozen	Replace the fuel, apply proper fuel type.
2. Water in fuel	Clean oil tank and replace fuel
3. Failure of injector	Adjust pressure or clean up carbon deposit, grind or replace parts
4. Injector doesn't work or bad fuel supply of oil pump	Fasten type T bolt of oil supply pipe, evacuate air in the pipe.
C. Insufficient compression force	
1. Nuts of cylinder head is loosened, or cylinder gasket is damaged	Fasten nuts or replace gasket
2. Piston ring, piston, or cylinder liner is worn out.	Repair or replace the part whichever is necessary.
3. Piston ring is banded or broken	Clean or replace the piston ring

This warranty is null & void, if you fail to register the warranty with KisanKraft by sending the KisanKraft Copy with dealer's stamp.

Cause	Remedy
4. Bad sealing of throttle and throttle seat causes gas leakage.	Grind throttle.
5. Improper clearance of air intake and exhaust valve.	Adjust as per relevant requirements
6. Throttle stem is seized in duct	Remove throttle and clean it
7. Too much drop of compression ratio even after adjusting throttle seat several times.	Replace throttle seat.
D. Improper oil supply advance angle	Adjust as per relevant requirements
E. Viscosity of engine oil is too large	Fill engine oil of right type and right grade.

Insufficient Engine Power:

Cause	Remedy
A. Failure of oil passage system	
1. Oil passage is blocked, unsmooth oil supply	Check the oil passage
2. Bad oil supply of injection pump	Repair or replace the necessary parts
3. Failure of injector	Refer to "difficulty in starting"
B. Insufficient compression force	Refer to "difficulty in starting"
C. Air filter is blocked	Clean or replace filter element
D. Rotary speed is too low	Throttle up
E. Improper oil supply advance angle	Adjust as per the requirements
F. Improper clearance of air intake and exhaust valve.	Adjust as per the requirements
G. Parts of injection pump or injector is worn out or injection pressure is insufficient	Replace parts and adjust injection pressure.

Unstable working or discontinuous eruption noise

Cause	Remedy
A. Failure of fuel system	
1. Air mixing in fuel system	Evacuate the air
2. Bad fuel quality or water mixing in fuel	Check the fuel and replace it if necessary
3. Injector parts are jammed or excessive injection pressure	Check injector and adjust injection pressure
4. Needle valve parts of injector is worn out or parts are blocked by injector stem	Check the parts and replace if necessary.
B. Speed regulating system is seized	Check, repair or replace the regulating valve.

Self-Shutdown of Diesel Engine:

This warranty is null & void, if you fail to register the warranty with KisanKraft by sending the KisanKraft Copy with dealer's stamp.

Cause	Remedy
A. Failure of fuel system	
1. Insufficient fuel in oil tank	Refill the fuel
2. Diesel oil filter and oil supply duct are blocked or gas leakage	Clean or evacuate the air
3. Injector parts are seized	Clean or grind parts and replace if necessary
B. Failure of lubrication system	
1. Insufficient engine oil in crank case causes damages of mechanical parts	Fill engine oil, repair damaged parts and replace if necessary
2. Bad lubrication of crank journal damages the bushing	Clean oil passage, repair damaged parts

Other Failures:

Cause	Remedy
A. Injector is seized often	
1. High temperature crash stop	Crash stop is not allowed.
2. Unclean fuel or damaged fuel filter.	Clean oil tank, replace fuel filter
B. Engine oil overflows from exhaust	
1. Piston or cylinder head is worn out	Check, repair and replace the piston or cylinder if necessary
2. Throttle duct is worn out	Check, repair and replace the throttle duct if necessary.
3. Piston ring is bonded or damaged	Clean or replace the piston ring
4. Excessive engine oil	Discharge engine oil until normal level is reached
C. Fluctuating rotary speed	
1. Gas leakage at the joint of oil supply pipe	Fasten the joint or replace gasket
2. Adjusting bolt on speed regulating spring is loosened.	Adjust and fasten
D. Black smoke in exhaust	
1. Overload	Reduce load
2. Improper power	Select proper power
3. Improper oil supply advance angle	Adjust as per relevant requirements
4. Incomplete combustion	Check injector quality and if compression force is sufficient

This warranty is null & void, if you fail to register the warranty with KisanKraft by sending the KisanKraft Copy with dealer's stamp.

E. Stop the engine immediately in case of any of the following circumstances:	
1. Fluctuating rotary speed	Check speed regulating system, air mixing in fuel passage and evacuate the air.
2. Abnormal noise suddenly	Check each moving part for any damage
3. Black smoke in exhaust	Check the fuel system for normal oil supply, particularly the injector.

Other Troubleshooting:

Symptom	Cause	Remedy
The Intercultural/Weeding Operations blade is broken	Collision with the hard things like stones when working	Replace the blade. Avoid colliding with hard things like stones in the earth when working
The manipulation cable is broken	Long-time abrasion in work	Replace the cable

Technical Specifications

Parameter		KK-IC-406D (With Differential Gear Box)	KK-IC-406D (Electric Start)	
Type		Diesel engine, 4 stroke	Electric Start	
Type of cooling		4-Stroke/Diesel	4-Stroke/ Electric	
Rated Power		5.5 kW (7.5 hp)		
Rated rotating speed		3600 RPM		
Rotate speed of power output shaft		3600 RPM		
Displacement		406 cc		
Ignition mode		Compression ignition		
Bore/Stroke		86/72		
Start mode		Recoil		
Fuel tank capacity		5.0 L		
Fuel consumption		0.77L/hr		
Engine oil capacity		1.65 Ltr		
Inter-cultivator	Machine's dimension (lengthxwidthxheight)		1030x570x880 Mm	
	Transmission System		Full Gear Transmission	
	Connection mode		Direct Connection	
	Speed	Running speed	Fast	10 Km/h
			Slow	5 Km/h
		Working Speed	Intercultural/Weeding Operations	0.5-1.3 Km/h
	Reversing speed		2(2 Fwd,1 Rev)	
	Blades	Rotate speed		129.78 R/min
		Max. Radius of gyration		180 Mm
		Total blades quantity		40 Pcs

This warranty is null & void, if you fail to register the warranty with KisanKraft by sending the KisanKraft Copy with dealer's stamp.

Parameter		KK-IC-406D (With Differential Gear Box)	KK-IC-406D (Electric Start)
	Total groups of blades	10	
	Blades for each group	4	
	Distance between 2 neighboring faces are cut	150 Mm	
	Diameter of the farming blades	36 Cm	
	Rotary blade type	Bent blade for dry land	
	Clutch mode	Wet multiple disc clutch land manual control	
	Intercultural/Weeding Operations Depth	≥10 Cm	
	Intercultural/Weeding Operations Width	135 Cm	
	Working efficiency	0.066-0.133 H m ² /h	
	Specific fuel consumption	320 g/kWh	
	Gearbox's oil capacity	2.4 Ltr	
	Sound pressure level	≤86 Db(A)	
Sound power level	≤93 Db(A)		
Intercultural/Weeding Operations Width	1.123 to 1.247 m		
Intercultural/Weeding Operations Depth	8 to 10 cm		

Note: KK-IC-406D has same specifications as KK-IC-400D. (same engine)
The only difference is that KK-IC-400D has 3 gears whereas KK-IC-406D has 6 shift gears. i.e., 3 gears in HIGH and 3 gears in Low as shown in the picture. (Circled part)

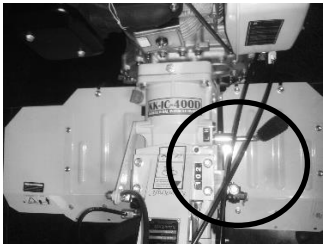

Note: **FREE HEADLIGHT** included

This warranty is null & void, if you fail to register the warranty with KisanKraft by sending the KisanKraft Copy with dealer's stamp.

Parts Diagram & List- ENGINE

CYLINDER BLOCK ASSEMBLY

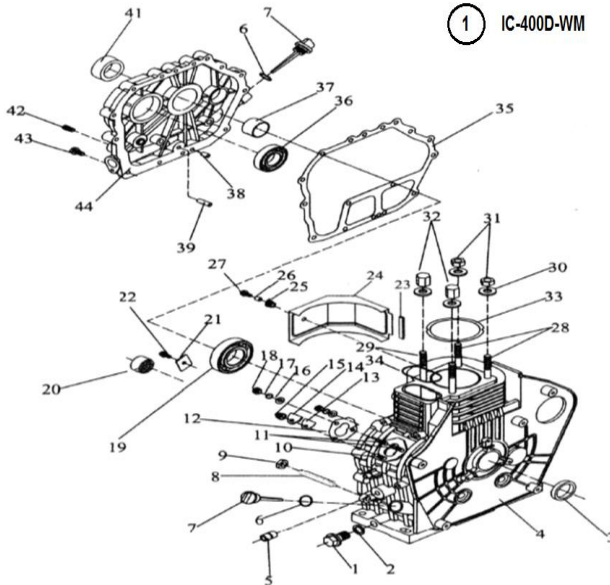

Part No	Part Name	Part No	Part Name
E1-01	Drain Plug	E1-23	Cushion Blocking
E1-02	Washer (Drain Plug)	E1-24	Governor
E1-03	Oil Seal Sg35*50*8	E1-25	Vibration Isolation Cushion Block
E1-04	Cylinder Block.	E1-26	Sheath
E1-05	Needle Bearing/Hk081410	E1-27	Bolt M6*20
E1-06	O-Ring 24*2.4(Oil Cap)	E1-28	Cylinder Head Stud / M10*105
E1-07	Oil Filler Cap	E1-29	Cylinder Head Stud / M10*118
E1-08-09	Fuel Controller	E1-30	Washer (Head Nut)
E1-10	Stud AM6*30	E1-31	Cylinder Head Nut (Short)
E1-11	Stud AM6*40	E1-32	Cylinder Head Nut (Long)

This warranty is null & void, if you fail to register the warranty with KisanKraft by sending the KisanKraft Copy with dealer's stamp.

Part No	Part Name	Part No	Part Name
E1-12	Fuel Injection Pump Gasket	E1-33	Cylinder Head Shim
E1-13	Seal Gasket (Fuel Pump)	E1-34	Cylinder Rubber Ring
E1-14	Seal Plate (Fuel Pump)	E1-35	Crank Case Gasket
E1-15	Nut M6	E1-36	Ball Bearing 6206/P5
E1-16	Washer 6	E1-37	Main Bearing
E1-17	Spring Washer 6	E1-38	Pin 8*12
E1-18	Nut M6	E1-39	Oil Pipe
E1-19	Ball Bearing 6308/P5	E1-41	Oil Seal SG35*50*10
E1-20	Needle Bearing HM1512	E1-42	Hexagonal Internal Screw Plug
E1-21	Retainer (Bearing)	E1-43	Bolt M8 * 33.5
E1-22	Bolt M8*16	E1-44	Crank Case Cover

CYLINDER ASSEMBLY

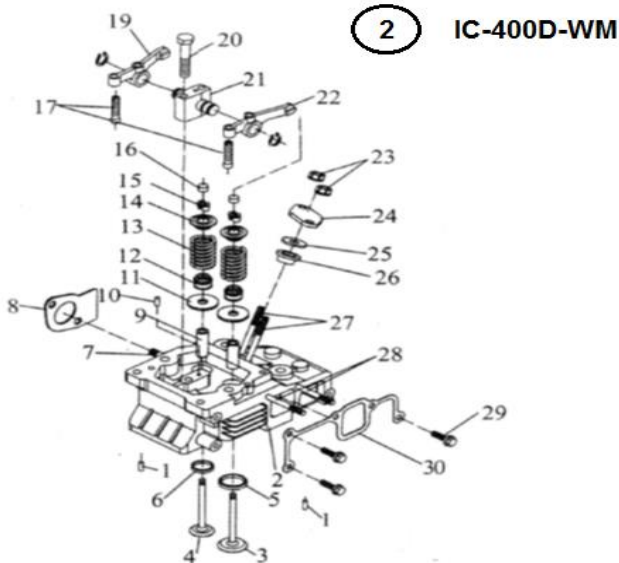

Part No	Part Name	Part No	Part Name
E2-01	Pin 4*8	E2-16	Valve Adjusting Plate

This warranty is null & void, if you fail to register the warranty with KisanKraft by sending the KisanKraft Copy with dealer's stamp.

E2-02/05/06/09	Cylinder Head	E2-17/18//9/21/22	Rocker Arm Assy
E2-03	Intake Valve	E2-20	Bolt M8*45
E2-04	Exhaust Valve	E2-23	Nut M6
E2-07	Stud AM8*32	E2-24	Injector Clamp
E2-08	Silencer Gasket	E2-25	Spacer Washer (Injector)
E2-10	Pin 4*8	E2-26	Insulation Sleeve
E2-11	Valve Spring Washer	E2-27	Stud AM6*67
E2-12	Valve Conduit Oil Seal	E2-28	Stud AM6*95
E2-13	Valve Spring	E2-29	Bolt M6*25
E2-14	Valve Spring Retainer	E2-30	Air Intake Gasket
E2-15	Cotter	E2-16	Valve Adjusting Plate

CYLINDER HEAD BONNET ASSEMBLY

Part No	Part Name	
E3-01	Bonnet Gasket	
E3-02	Bolt /M6*70	
E3-03	Bonnet Assy	

PISTON&CONNECTING ROD ASSEMBLY

Part No	Part Name	
E4-01	Piston Ring Set	
E4-02	Piston	
E4-03	Piston Pin	
E4-04	Circlip Piston Pin	
E4-05	Connecting Rod Assy	
E4-06	Crank Pin Bearing	

This warranty is null & void, if you fail to register the warranty with KisanKraft by sending the KisanKraft Copy with dealer's stamp.

CRANK SHAFT & FLYWHEEL ASSEMBLY

Part No	Part Name
E5-01	Ball Bearing 6203/P5
E5-02	Balancer Shaft
E5-03	Key 5x7
E5-04	Timing Gear Of Balance Shaft
E5-08	Crankshaft Timing Gear
E5-10	Crank Shaft
E5-11	Steel Ball
E5-12	Key 5x12
E5-13	Drive Gear Of Balance Shaft
E5-15	Fly Wheel
E5-16	Fly Wheel Nut Washer
E5-17	Fly Wheel Nut/ M18*1.5
E5-18	Starter Pulley
E5-19	Bolt M6*12
E5-20	Key 5x14

5 IC-400D - WM

CANSHAFT ASSEMBLY

Part No	Part Name
E6-01	Valve Rod Assy
E6-02	Valve Tappet
E6-03	Camshaft Timing Gear
E6-04	Key 5*14
E6-05	Camshaft

6 IC-400D-WM

This warranty is null & void, if you fail to register the warranty with KisanKraft by sending the KisanKraft Copy with dealer's stamp.

AIR CLEANER ASSEMBLY



Part No	Part Name	Part No	Part Name
E7-01	Shock Absorber Seat	E7-04	Collar10*10
E7-02	Fan Case Welded Assy	E7-05	Washer 6
E7-03	Shock Absorber	E7-06	Bolt M6*25

SILENCER /MUFFLER ASSEMBLY

Part No	Part Name	
E8-01	Silencer Assy	
E8-02	Nut 8	
E8-03	Spring Washer 6	
E8-04	Washer 8	
E8-05	Bolt M8*16	

LUBE OIL SYSTEM /Oil Pump Assy

Part No	Part Name	
E10-01	Bolt M6*12	
E10-02	Oil Pump Cover	
E10-03	O-Ring 34.8*1.8	
E10-04	Pin 3*16	
E10-05	Oil Pump Assy	
E10-06	Oil Pump Gear	
E10-09	O-Ring 242.4	
E10-10	Oil Filter Assy	
E10-11	Bolt M6*14	

This warranty is null & void, if you fail to register the warranty with KisanKraft by sending the KisanKraft Copy with dealer's stamp.

FUEL TANK & FUEL PIPE ASSEMBLY

Part No	Part Name
E11-01	Bolt M8x45
E11-02	Upper Stay Bolt
E11-03	Washer 8
E11-04	Upper Stay
E11-05	Fuel Tank Damper
E11-06	Fuel Return Pipe Assy
E11-08	Fuel Tank Plug Seat
E11-09	Fuel Tank Plug
E11-10	Lower Stay Assy
E11-11	Bolt M6*14
E11-12	Nut 6
E11-13	Fuel Tank Cock Assy
E11-14	O-Ring 13.2*1.8
E11-15	Fuel Pipe Assy
E11-17	Fuel Filter Gasket
E11-18	Fuel Filter Assy
E11-19	Fuel Injection Pipe Assy
E11-20	Fuel Tank Assy
E11-21	Fuel Tank Cap Assy

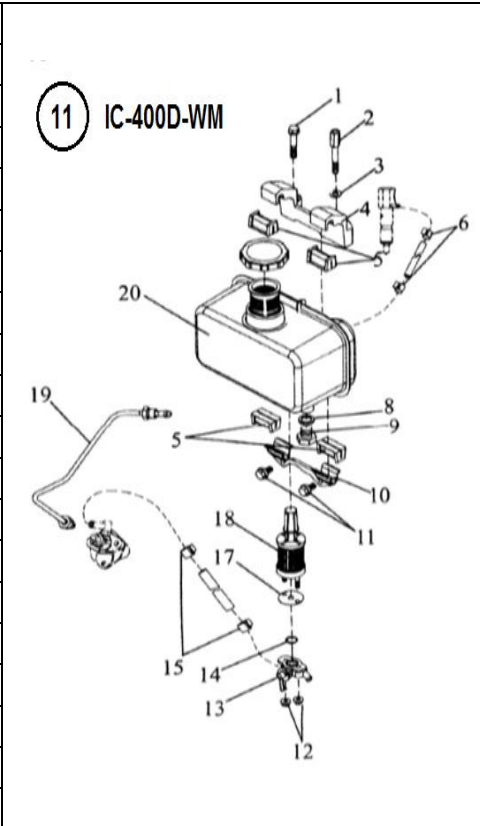

This warranty is null & void, if you fail to register the warranty with KisanKraft by sending the KisanKraft Copy with dealer's stamp.

GOVERNOR& CONTROL SYSTEM

Part No	Part Name	
E13-01	Tappet 25.5	
E13-02	Lever Fork	
E13-03	Oil Seal 8x14x4	
E13-04	Lever Washer	
E13-05	Return Spring	
E13-06	Governor Spring	
E13-07	Fine Spring	
E13-08-1	Control Lever Assy.	
E13-09	Nut M6x12	
E13-10	Nut M6x25	

AIR CLEANER ASSEMBLY

Part No	Part Name	
E14-00	Air Filter Assy(Oil Bath)	
E14-01	Air Filter Body	
E14-1-1	Air Filter Top Cover	
E14-1-2	Air Filter sponge (Big)	
E14-1-2	Air Filter sponge (Small)	
E14-02	Air Filter sponge (for sump)	
E14-2-1	Sump filter body (Big)	
E14-2-2	Sump filter body (Small)	
E14-03	Air Filter Sump	
E14-04	Bolt M8x16	
E14-05	Air Cleaner Gasket	
E14-06	Intake Pipe Bending	
E14-07	Bolt M6x25	
E14-08	Nut M6	
E14-09	Intake Pipe Bending Gasket	
E14-10	Intake Pipe	

FUEL NOZZLE ASSEMBLY

This warranty is null & void, if you fail to register the warranty with KisanKraft by sending the KisanKraft Copy with dealer's stamp.

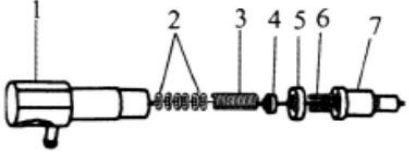
Part No	Part Name	
E15-00	Fuel Injector	
E15-07	Nozzle (Fuel Injector)	

FUEL INJECTION PUMP ASSEMBLY

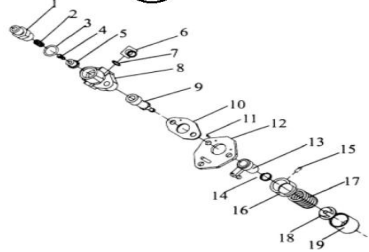
Part No	Part Name	
E16-00	Fuel Injector Pump Assy	
E16-08/9	Plunger Set	
E16-10	Gasket (Flip Block)	
E16-19	Tappet	

RECOIL STARTER ASSEMBLY

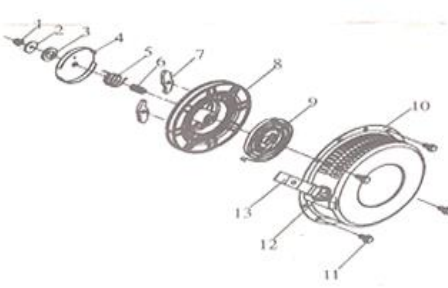
Part No	Part Name	
E17-00	Recoil Starter Assy	
E17-01	Nut M8	
E17-02	Washer (Starter)	
E17-03	Friction Plate	
E17-04	Starter Ratchet Reel	
E17-05	Return Spring	
E17-06	Compression Spring	
E17-07	Ratchet	
E17-08	Starter Reel	
E17-09	Spiral Spring	
E17-10	Outer Case Assy	
E17-11	Bolt M6 x 10	
E17-12	Starter Rope	
E17-13	Starter Handle	

This warranty is null & void, if you fail to register the warranty with KisanKraft by sending the KisanKraft Copy with dealer's stamp.

Parts Diagram - Gearbox

Intercultivator Exploded View

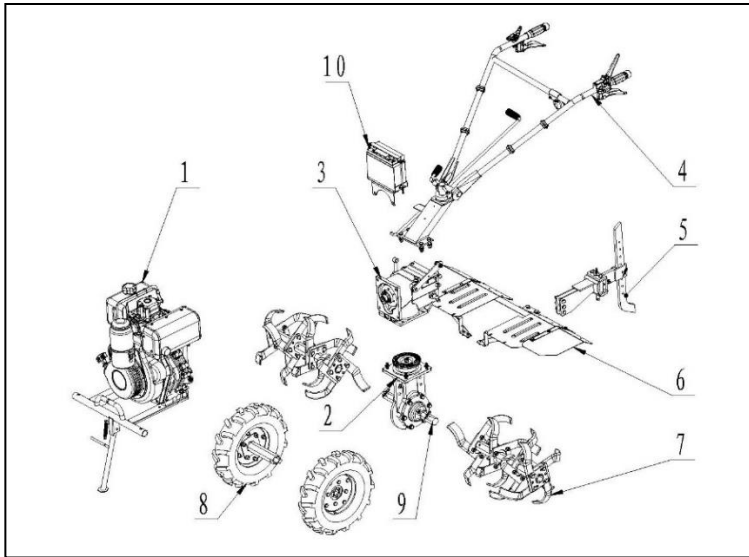

Ref No	Description	Ref No	Description
1	Handrail parts	6	Bumper, engine support frame and flange parts
2	Shifting Gearbox Assy	7	Fender parts
3	Walking case Assy	8	Dragging bar, connecting frame and resistance rod parts
4	Rotary blades parts	9	Output shaft parts
5	Wheels parts		

This warranty is null & void, if you fail to register the warranty with KisanKraft by sending the KisanKraft Copy with dealer's stamp.

Handrail Parts

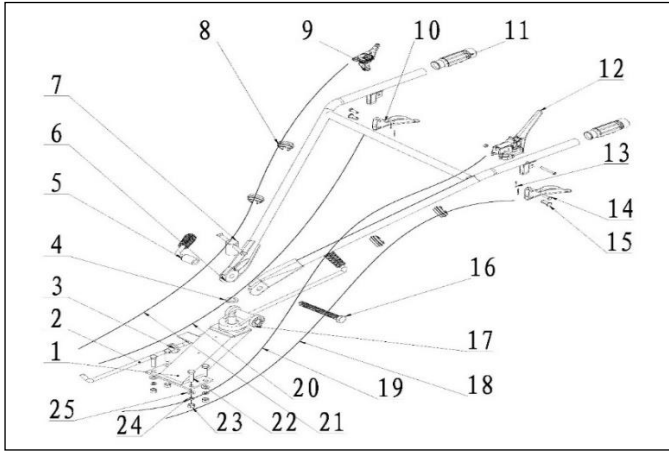

Ref No	KK Part No	KK Part Name	Ref No	KK Part No	KK Part Name
1	G/B 1-01	Handrail seat	14	G/B 1-14	Pin 8*24
2	G/B 1-02	Shift lever	15	G/B 1-15	Lacing cord connector
3	G/B 1-03	Scuff sleeve, handrail seat	16	G/B 1-16	Hexagon head bolts- M16*150
4	G/B 1-04	Spring washer20*5(st andard type)	17	G/B 1-17	Tray, gear
5	G/B 1-05	Locked lever	18	G/B 1-18	Clutch cable
6	G/B 1-06	Handrail	19	G/B 1-19	Flameout switch cable
7	G/B 1-07	T figure locked lever	20	G/B 1-20	Reverse cable
8	G/B 1-08	Cable clip	21	G/B 1-21	Throttle cable
9	G/B 1-09	Throttle switch Φ25(MF type)	22	G/B 1-22	Hexagon head bolts- M10*40
10	G/B 1-10	Reverse/clutch handlebar	23	G/B 1-23	Hex nut M10(C grade 1 type)
11	G/B 1-11	Handlebar rubber sleeve Φ25	24	G/B 1-24	Spring washer 10*2.6(standar d)

This warranty is null & void, if you fail to register the warranty with KisanKraft by sending the KisanKraft Copy with dealer's stamp.

Ref No	KK Part No	KK Part Name	Ref No	KK Part No	KK Part Name
12	G/B 1-12	Flameout switch	25	G/B 1-25	Washer 10*2(C grade)
13	G/B 1-13	Cotter pin 1.6*20(B type)			

Shifting Gearbox Assy

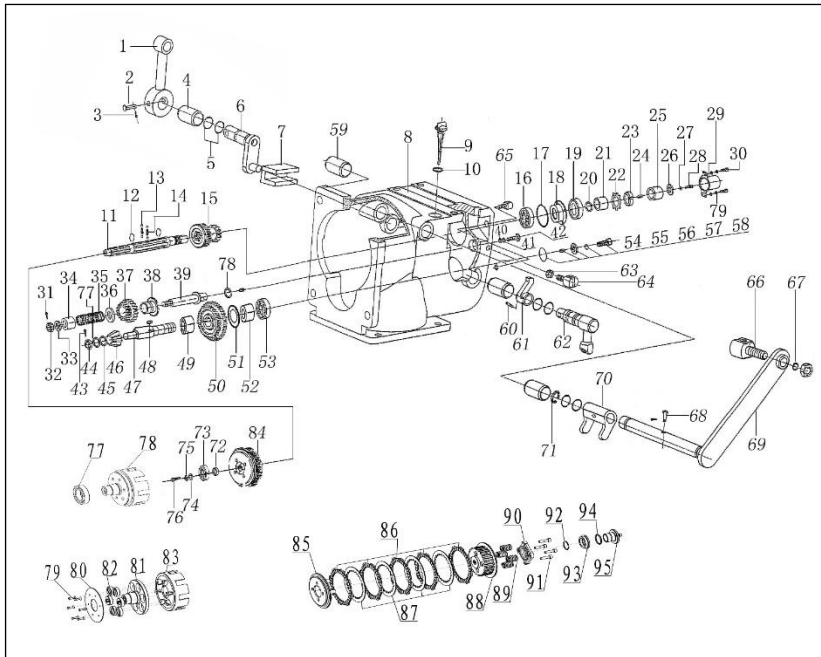

Ref No	KK Part No	KK Part Name	Ref No	KK Part No	KK Part Name
1	G/B 2-1	Sheath, Shift rod	49	G/B 2-48	needle bearing K182420
2	G/B 2-2	Pin 6x40, Shift rod	50	G/B 2-49	Double gear, countershaft
3	G/B 2-3	Clip A	51	G/B 2-50	adjusting Gasket, countershaft
4	G/B 2-4	shift shaft sleeve 20*16*35.5	52	G/B 2-51	Sheath, countershaft

This warranty is null & void, if you fail to register the warranty with KisanKraft by sending the KisanKraft Copy with dealer's stamp.

Ref No	KK Part No	KK Part Name	Ref No	KK Part No	KK Part Name
5	G/B 2-5	O-ring 11.2x2.65	53	G/B 2-52	Thrust ball bearing 51104
6	G/B 2-6	shift shaft/shift fork shaft	54	G/B 2-53	O-ring 25x1.8
7	G/B 2-7	Shift block	56	G/B 2-54	Gasket 41x12.5x4
8	G/B 2-8	gear box	57	G/B 2-55	Spring washer 12
9、 10	G/B 2-9	dipstick (with O- ring)	58	G/B 2-56	hexagon Bolt M12x1.25x25
11	G/B 2-10	Principal axes	59	G/B 2-57	reverse gear/clutch fork shaft sheath 20x16x31.5
12	G/B 2-11	steel wire retainer ring for axe	60	G/B 2-58	Worm column pin 5x30
13	G/B 2-12	Steel ball SΦ6	61	G/B 2-59	Reverse gear fork
14	G/B 2-13	Spring, Principal axes	62	G/B 2-60	Axes, reverse gear fork
15	G/B 2-14	Initiative gear	63	G/B 2-61	Nut M8
16	G/B 2-15	Bearing 6204	64	G/B 2-62	Seat, reverse gear cable
17	G/B 2-16	O-ring 45x1.8	65	G/B 2-63	Seat, clutch cable
18	G/B 2-17	Pushing panel	66	G/B 2-64	Seat, clutch cable
19	G/B 2-18	lip Oil seal B25x40x7(prop ylene)	67	G/B 2-65	Spring washer 8
20	G/B 2-19	O-ring 17x2	68	G/B 2-66	Pin 6x20, clutch fork
21	G/B 2-20	Sheath, principal axes	69	G/B 2-67	Axes, clutch fork
22	G/B 2-21	thrust-washer 20	70	G/B 2-68	Clutch fork
23	G/B 2-22	Round Nut M20x1.5	71	G/B 2-69	Ring 16
24	G/B 2-23	Key A6x6x20	72	G/B 2-70	Clutch washer 26*15.3*2.7

This warranty is null & void, if you fail to register the warranty with KisanKraft by sending the KisanKraft Copy with dealer's stamp.

Ref No	KK Part No	KK Part Name	Ref No	KK Part No	KK Part Name
25	G/B 2-24	Sheath, Key	73	G/B 2-71	deep groove ball bearing 6202
26	G/B 2-25	Gasket 8x28x3	74	G/B 2-72	Gasket 8
27	G/B 2-26	Spring washer 6	75	G/B 2-73	External teeth serrated lock washer
28	G/B 2-27	Hex bolts M6x20	76	G/B 2-74	Hexagon bolt M8x20
29	G/B 2-28	Protect cover, principal axes	77	G/B 2-75	deep groove ball bearing 6007
30	G/B 2-29	Inner hexagon Screw M6x20	78	G/B 2-76	clutch cover assy
31	G/B 2-30	Cotter pin 2.5x30	79	G/B 2-77	Countersunk rivet 6
32	G/B 2-31	Hexagon slotted nut M12	80	G/B 2-78	Cover, cushion
33	G/B 2-32	Washer 12	81	G/B 2-79	Spline plate, clutch
34	G/B 2-33	Restrict cover, reverse gear	82	G/B 2-80	Cushion
35	G/B 2-34	Reverse gear Spring	83	G/B 2-81	Cover, clutch
36	G/B 2-35	Spring seat, reverse gear	84	G/B 2-82	Core comp, clutch
37	G/B 2-36	Double gear, reverse gear	85	N/A	
38	G/B 2-37	Pushing plate, reverse gear	86	G/B 2-83	Friction piece
39	G/B 2-38	Axes, reverse gear	87	G/B 2-84	steel piece
40	G/B 2-39	counter shaft adjusting washer/counter shaft washer	88	N/A	
41	G/B 2-40	Spring washer 10	89	N/A	
42	G/B 2-41	Bolt M10x25	90	N/A	
43	G/B 2-42	cotter pin 2x30	91	N/A	Inner hexagon screw M5x20

This warranty is null & void, if you fail to register the warranty with KisanKraft by sending the KisanKraft Copy with dealer's stamp.

Ref No	KK Part No	KK Part Name	Ref No	KK Part No	KK Part Name
44	G/B 2-43	Hexagon slotted nut M10	92	N/A	steel wire retainer ring for axe
45	G/B 2-44	Adjusting gasket	93	N/A	Hexagon Fixed sheath
46	G/B 2-45	Initiative umbrella gear	94	N/A	Ball bearing S ϕ 3.5
47	G/B 2-46	Countershaft	95	N/A	Active Pushing cover
48	G/B 2-47	Key A6x6x20			

Walking Case Assy

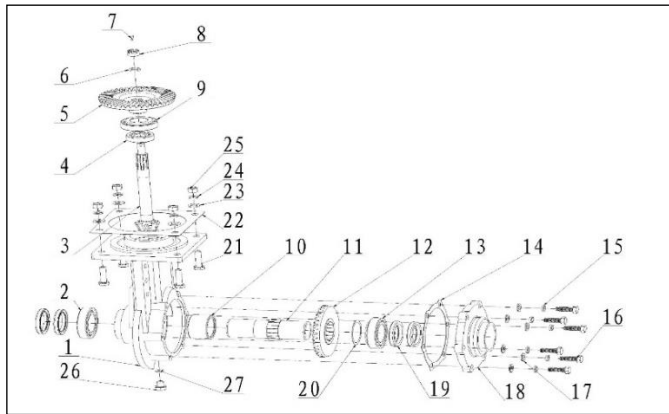

Ref No	KK Part No	KK Part Name	Ref No	KK Part No	KK Part Name
1	G/B 3-1	Walking case	15	G/B 3-15	spring washer 10*2.6
2	G/B 3-2	Deep groove ball bearing 6009	16	G/B 3-16	Hexagon bolt M10*30
3	G/B 3-3	Umbrella gear axes	17	G/B 3-17	gasket 10*2
4	G/B 3-4	Taper roller bearing 30204	18	G/B 3-18	walking case cover
5	G/B 3-5	Driven umbrella gear	19	G/B 3-19	lip seal 45*62*8

This warranty is null & void, if you fail to register the warranty with KisanKraft by sending the KisanKraft Copy with dealer's stamp.

Ref No	KK Part No	KK Part Name	Ref No	KK Part No	KK Part Name
6	G/B 3-6	Spring washer 12*3.1	20	G/B 3-20	adjusting gasket 0.1 for umbrella gear
7	G/B 3-7	Cotter pin 2*30			adjusting gasket 0.5 for umbrella gear
8	G/B 3-8	Thin slotted nut M12	21	G/B 3-21	gasket of walking case
9	G/B 3-9	Taper roller bearing 30206	22	G/B 3-22	Hexagon head bolts M10*40
10	G/B 3-10	Output shaft bush	23	G/B 3-23	washer 10*2
11	G/B 3-11	hexagonal output shaft sleeve	24	G/B 3-24	standard spring washer 10*2.6
12	G/B 3-12	Walking umbrella gear	25	G/B 3-25	hexagon nut M10
13	G/B 3-13	Taper roller bearing 32009	26	G/B 3-26	hexagon bolt M12*1.25*12
14	G/B 3-14	gasket of walking case cover	27	G/B 3-27	O-ring 10.2*2.65

Rotary Blades Parts

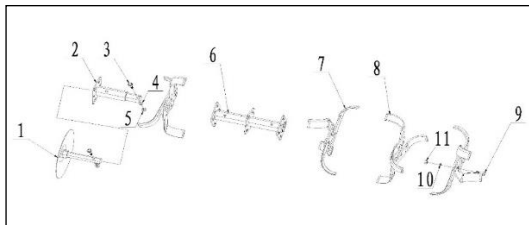

Ref No	KK Part No	KK Part Name	Ref No	KK Part No	KK Part Name
1	G/B 4-1	Side Disk	7	G/B 4-7	Dry land Blade(L)
2	G/B 4-2	Counter tube	8	G/B 4-8	Dry land Blade(R)
3	G/B 4-3	Bolt M8x55	9	G/B 4-9	Hex bolt M10x35
4	G/B 4-4	Spring washer 8	10	G/B 4-10	Nut M10
5	G/B 4-5	Nut M8	11	G/B 4-11	Spring washer 10

This warranty is null & void, if you fail to register the warranty with KisanKraft by sending the KisanKraft Copy with dealer's stamp.

6	G/B 4-6	Main tube			
---	---------	-----------	--	--	--

Wheels Parts

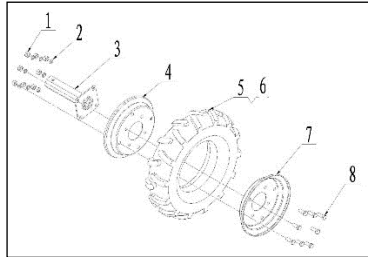

Ref No	KK Part No	KK Part Name	Ref No	KK Part No	KK Part Name
1	G/B 5-1	Hex Nut M10	5	G/B 5-5	Inner tube
2	G/B 5-2	Spring washer 10	6	G/B 5-6	Outer rubber tyre 4.00-8
3	G/B 5-3	Wheel axle/black	7	G/B 5-7	Spoke (outer side with hole)
4	G/B 5-4	Spoke (inner side)	8	G/B 5-8	Hex bolt M10x30
Note	Ref no: 4.5.6.7. will be new type Tyre without inner tube in latest models				

This warranty is null & void, if you fail to register the warranty with KisanKraft by sending the KisanKraft Copy with dealer's stamp.

Bumper, Engine Support Frame and Flange Parts

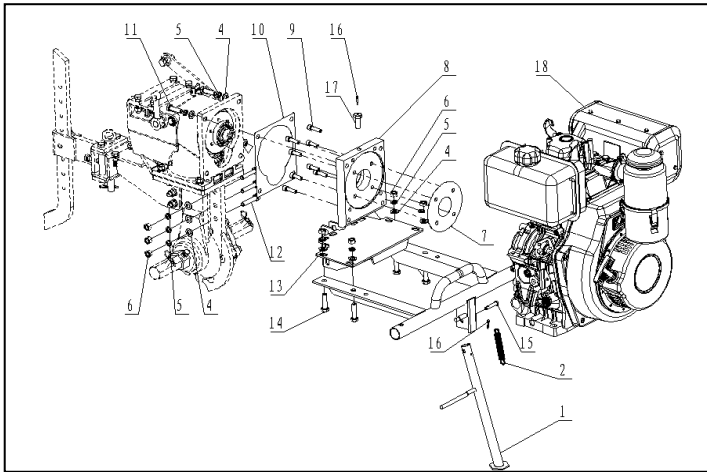

Ref No	KK Part No	KK Part Name	Ref No	KK Part No	KK Part Name
1	G/B 6-1	Support bar of bumper	11	G/B 6-12	Hexagon head bolts-full thread M10*40
2	G/B 6-2	Draw spring, support bar of bumper	12	G/B 6-13	Hexagon head bolts-full thread M10*40
3	G/B 6-3	bumper (WM1100A)	13	G/B 6-14	Engine support frame (WM1100A)
	G/B 6-4	bumper (WM1100B)		G/B 6-15	Engine support frame (WM1100B)
4	G/B 6-5	washer 10*2 (C grade)	14	G/B 6-16	Hexagon head bolts-full thread M10*50
5	G/B 6-6	gasket 10*2.6(Standard type)	15	G/B 6-17	Pin 8*43(B type)
6	G/B 6-7	hex nut M10(A and B grade)	16	G/B 6-18	Cotter pin 2*30(B type)
7	G/B 6-8	flange gasket	17	G/B 6-19	Hexagon bolt M12*1.25*25
8	G/B 6-9	flange (WM1100A/B)	18	N/A	Diesel engine (WM178F)

This warranty is null & void, if you fail to register the warranty with KisanKraft by sending the KisanKraft Copy with dealer's stamp.

Ref No	KK Part No	KK Part Name	Ref No	KK Part No	KK Part Name
9	G/B 6-10	Hexagon socket head cap screw M8*35		N/A	Diesel engine (WM186FB)
10	G/B 6-11	Gear box gasket		N/A	Diesel engine (WM186FBE)

Fender Parts

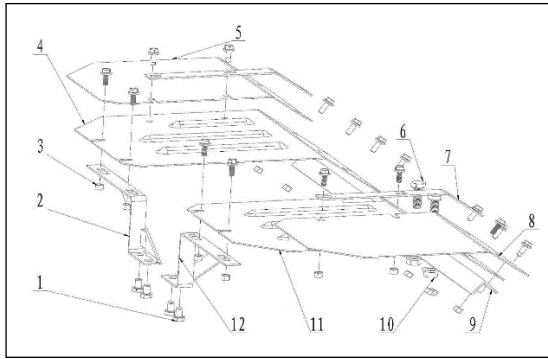

Ref No	KK Part No	KK Part Name	Ref No	KK Part No	KK Part Name
1	G/B 7-1	Hexagon head bolts- M8*12	7	G/B 7-8	batten
2	G/B 7-2	Fender support(right)	8	G/B 7-9	vice fender(left)
3	G/B 7-3	Hexagon nut M6	11	G/B 7-10	fender (left)
	G/B 7-4	Hexagon head bolts- M6*16	9	G/B 7-11	fender back support
4	G/B 7-5	fender(right)	10	G/B 7-12	Hexagon nut M10
5	G/B 7-6	vice fender (right)	12	G/B 7-13	fender support(left)
6	G/B 7-7	Hexagon bolt M10*25			

This warranty is null & void, if you fail to register the warranty with KisanKraft by sending the KisanKraft Copy with dealer's stamp.

Trailer Body, Connecting Frame and Resistance Rod Parts

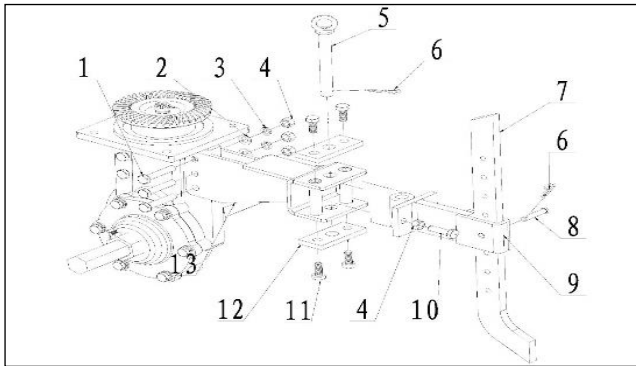

Ref No	KK Part No	KK Part Name	Ref No	KK Part No	KK Part Name
1	G/B 8-1	Hexagon head bolts-M10*50	8	G/B 8-8	Pin 8*43
2	G/B 8-2	washer 10*2	9	G/B 8-9	connecting frame
3	G/B 8-3	spring washer 10*2.6	10	G/B 8-10	Hexagon head bolts-M10*30
4	G/B 8-4	Hexagon not M10	11	G/B 8-11	Hexagon head bolts-M10*20
5	G/B 8-5	Pin with hoop	12	G/B 8-12	Strengthen plate, trailer body
6	G/B 8-6	Clip B	13	G/B 8-13	Dragging bar
7	G/B 8-7	resistance rod			

This warranty is null & void, if you fail to register the warranty with KisanKraft by sending the KisanKraft Copy with dealer's stamp.

Output Shaft Parts

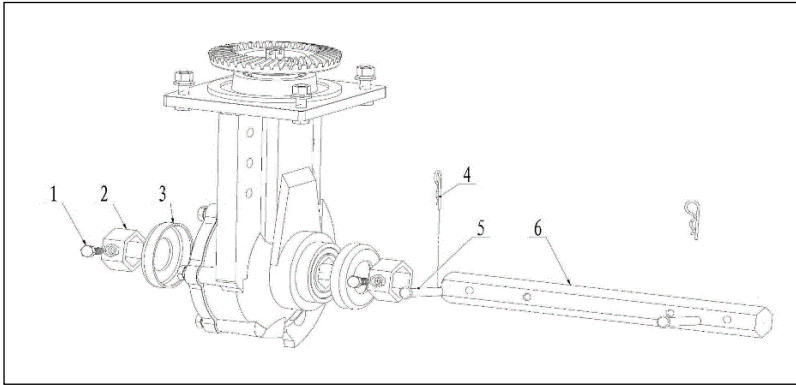

Ref No	KK Part No	KK Part Name	Ref No	KK Part No	KK Part Name
1	G/B 9-1	Hexagon head bolts- M8*16	4	G/B 9-4	clip B
2	G/B 9-2	hexagon retainer sleeve	5	G/B 9-5	Pin 8*50
3	G/B 9-3	dust cover	6	G/B 9-6	Hexagon output shaft

This warranty is null & void, if you fail to register the warranty with KisanKraft by sending the KisanKraft Copy with dealer's stamp.



KisanKraft has a large range of products to serve the farmers. A list of our products is given below:

<p>Brush Cutters and Accessories</p> <ul style="list-style-type: none"> Brush Cutter/Power Weeder Backpack Brush Cutter Tea Pruner Pole pruner with Engine Reaper Attachment Blades-Circular Blades (2 & 3 points) Baffle Nylon Rope Tap & Go <p>Chainsaws</p> <ul style="list-style-type: none"> Petrol Chainsaw Electric Chainsaw Chain Sharpening Machine <p>Engines and Water Pumps</p> <ul style="list-style-type: none"> Engine –Diesel-(Horizontal) Engine –Diesel (Vertical) Engine-Kerosene Water Pump with Petrol Engine Water Pump with Kerosene Engine Water Pump with Diesel Engine <p>Hand Tools</p> <ul style="list-style-type: none"> Secateurs Folding Saw Garden Rake Garden Shovel Hedge Shear Lopper Telescopic Hedge Shear Telescopic Lopping Shear Tree Pruner Telescopic Steel Pipe & Fruit Picker Bag Sheep Shear <p>Garden Tools</p> <ul style="list-style-type: none"> Electric Pressure Washer Hedge Trimmer Lawn Mower (Electric, Petrol & Manual) Leaf Blower 	<p>Cultivators and Accessories</p> <ul style="list-style-type: none"> Petrol and Diesel <p>Sprayers and Accessories</p> <ul style="list-style-type: none"> Battery Sprayer Portable Power Sprayer Trolley Sprayer Manual Knapsack Sprayer Manual Pressure Sprayer Rose Cans Hose Crimping Machine HTP Sprayer HTP Delivery Hose HTP Hose Reel HTP Stand HTP Gun / Lance (Brass Rod) Knapsack Power Sprayer Mister / Duster / Granule Spreader HTP Sprayer Set with Diesel Engine HTP Sprayer Set with Kerosene Engine Fogging Machine <p>Milking Machine</p> <ul style="list-style-type: none"> Wood Shredder Fodder Ensiling Chaff Cutter Fodder Grinder Chaff Cutter Fodder Mini Chaff Cutter <p>Harvester</p> <ul style="list-style-type: none"> Maize Sheller Maize Sheller + Dehusker Maize Combine Harvester Onion Digger Carlotta Italy Tea Leaf Harvester Sugarcane Combine Harvester Sugarcane Leaf Stripper <p>Transplanter and Post Hole Digger</p> <ul style="list-style-type: none"> Paddy Transplanter (2 & 8 Rows) Transplanter-Vegetable & Tobacco Post Hole Digger (4" to 14" Augers)
---	--

This warranty is null & void, if you fail to register the warranty with KisanKraft by sending the KisanKraft Copy with dealer's stamp.



Wide Range of Products for Every Need



For more information give **MISSED CALL: 07676065555**



Many of our products have BIS: ISI certification.



This warranty is null & void, if you fail to register the warranty with KisanKraft by sending the KisanKraft Copy with dealer's stamp.

Product	Agricultural Inter-Cultivator	KisanKraft Invoice Date	
Brand	KisanKraft	KisanKraft Invoice No.	
Model	<input type="checkbox"/> KK-IC-406D <input type="checkbox"/> KK-IC-406D (Electric Start)		
WARRANTY PERIOD	6 MONTHS	FOR THE SPECIFIED PERIOD FROM THE DATE OF SALE OR DELIVERY WHICHEVER IS EARLIER.	
Dealer's Invoice Date		Dealer's Invoice No.	
Buyer's Info (Name, Address, Phone, etc.):		Dealer's Stamp (Address, Phone, TIN, etc.):	
Buyer's Sign		Dealer's Sign	

Warranty Policy

What is covered: KisanKraft Limited and its manufacturers warrant this product to be free from defects in material or workmanship. All parts defective in material and workmanship are covered.

This warranty will only cover defects arising under normal usage.

This warranty is limited to repair or replacement by KisanKraft Limited or its manufacturers of such parts as appear to KisanKraft or its manufacturers, upon inspection, to be defective in material and/or workmanship. KisanKraft or its manufacturers make no warranty with respect to items not manufactured or sold by them. No onsite warranty is provided by KisanKraft Limited or its manufacturers. Defective items must be brought/sent to our Authorized Dealer or KisanKraft Limited's office for service.

What is not covered: The *warranty shall become null and void* and neither KisanKraft Limited nor any of its manufacturers, nor its authorized dealers assume any responsibility, if the failure was caused by the following:

(1) Operation of product with incorrect fuel or lubricants, (2) Incorrect usage of machine or misuse, (3) Lack of maintenance, (4) Negligence, (5) Accident or physical damage, (6) Repairs made by unauthorized parties and/or with unauthorized parts, (7) Improper set up, adjustments, tampering or altered products (8) Any modification to the product what-so-ever.

Important: (1) Normal maintenance and adjustments to the product is the responsibility of the customer. (2) Normal wear and tear are not covered under warranty. (3) Rubber/plastic parts and consumables such as blades, clutch and clutch-bell, sparkplugs, nylon line, air-filters, fuel-filters, oil seals and gaskets etc. are not covered under the warranty. (4) Electrical Motor, Electrical Parts, Battery Etc. are not covered under the warranty.

Incidental / Consequential Loss: KisanKraft Limited or its manufacturers will not be liable for general damages, including bodily injuries, or for incidental or consequential damages

This warranty is null & void, if you fail to register the warranty with KisanKraft by sending the KisanKraft Copy with dealer's stamp.

including, but not limited to, loss of use, loss of profits, loss of production, expense of substitute equipment or other commercial loss or damage.

Limitation of Liability: This limited warranty is in lieu of all other express warranties, obligations, or liabilities. Any implied warranties, obligations or liabilities, including, but not limited to, any implied warranty of merchantability shall be limited in duration to the applicable warranty period. Any action for breach of any warranties hereunder, including, but not limited to, any implied warranty of merchantability must be brought within the applicable warranty period.

Modifications of Warranty: No agent, representative, dealer, or employee of KisanKraft Limited or any of its manufacturers has the authority to increase or alter the obligations of this warranty.

Assignment / Transfer of warranty: The warranty cannot be assigned and shall not transfer if the product is resold by the first buyer. The above warranties are extended to the first end user (original purchaser), and no warranty is made, nor authorized to be made assignable on resale by the first end user.

What you must do to obtain limited warranty service: To obtain performance of any obligation under this warranty for failure during the applicable warranty period, you must deliver the defective product, to the nearest Authorized Dealer, along with proof-of-purchase (invoice/receipt). KisanKraft Limited, its manufacturers and its dealers reserve the right to inspect the claimed defective part(s) to determine if the malfunction is the result of a defect covered by this warranty. Please note that the decision of KisanKraft Limited with respect to any warranty claim is final.

After-sales Service (Including Warranty): KisanKraft Limited does not sell directly to consumers. All sales or supplies are made through Authorized Dealers. It is the responsibility of the Authorized Dealer to provide all after-sales service to consumers. Any warranty claim should be raised by dealer to KisanKraft Limited as per warranty policy.

Jurisdiction: All disputes are subject to Bangalore court's jurisdiction.

Notes:

- This purchase is not contingent upon a product demonstration. The purchaser shall satisfy himself with the product, including any product demonstration or verification of any function, before buying. KisanKraft Limited or its authorized dealers, including online sellers, shall not be liable to give any on-site demonstration after purchase of any of the product.
- Any product once used will not be taken back by KisanKraft Limited.
- Warranty and After Sale Services (including but not limited to installation, Demonstration, Repair, Routine Maintenance etc.), should be done through the Authorized Dealer selling this product.
- Dealers should have their own technician to provide After Sales Services to their Customers. KisanKraft Limited provides free training to Authorized Dealer's technicians at KisanKraft Limited's head office, on request from Authorized Dealer.

This warranty is null & void, if you fail to register the warranty with KisanKraft by sending the KisanKraft Copy with dealer's stamp.