

**Incidental / Consequential Loss:** KisanKraft Limited or its manufacturers will not be liable for general damages, including bodily injuries, or for incidental or consequential damages including, but not limited to, loss of use, loss of profits, loss of production, expense of substitute equipment or other commercial loss or damage.

**Limitation of Liability:** This limited warranty is in lieu of all other express warranties, obligations, or liabilities. Any implied warranties, obligations or liabilities, including, but not limited to, any implied warranty of merchantability shall be limited in duration to the applicable warranty period. Any action for breach of any warranties hereunder, including, but not limited to, any implied warranty of merchantability must be brought within the applicable warranty period.

**Modifications of Warranty:** No agent, representative, dealer, or employee of KisanKraft Limited or any of its manufacturers has the authority to increase or alter the obligations of this warranty.

**Assignment / Transfer of warranty:** The warranty cannot be assigned and shall not transfer if the product is resold by the first buyer. The above warranties are extended to the first end user (original purchaser), and no warranty is made, nor authorized to be made assignable on resale by the first end user.

**What you must do to obtain limited warranty service:** To obtain performance of any obligation under this warranty for failure during the applicable warranty period, you must deliver the defective product, to the nearest Authorized Dealer, along with proof-of-purchase (invoice/receipt). KisanKraft Limited, its manufacturers and its dealers reserve the right to inspect the claimed defective part(s) to determine if the malfunction is the result of a defect covered by this warranty. Please note that the decision of KisanKraft Limited with respect to any warranty claim is final.

**After-sales Service (Including Warranty):** KisanKraft Limited does not sell directly to consumers. All sales or supplies are made through Authorized Dealers. It is the responsibility of the Authorized Dealer to provide all after-sales service to consumers. Any warranty claim should be raised by dealer to KisanKraft Limited as per warranty policy.

**Jurisdiction:** All disputes are subject to Bangalore court's jurisdiction.

**Notes:**

- This purchase is not contingent upon a product demonstration. The purchaser shall satisfy himself with the product, including any product demonstration or verification of any function, before buying. KisanKraft Limited or its authorized dealers, including online sellers, shall not be liable to give any on-site demonstration after purchase of any of the product.
- Any product once used will not be taken back by KisanKraft Limited.
- Warranty and After Sale Services (including but not limited to installation, Demonstration, Repair, Routine Maintenance etc.), should be done through the Authorized Dealer selling this product.
- Dealers should have their own technician to provide After Sales Services to their Customers. KisanKraft Limited provides free training to Authorized Dealer's technicians at KisanKraft Limited's head office, on request from Authorized Dealer.

**This warranty is null & void, if you fail to register the warranty with KisanKraft by sending the KisanKraft Copy with dealer's stamp.**

🌐: [www.kisankraft.com](http://www.kisankraft.com)    ✉: [info@kisankraft.com](mailto:info@kisankraft.com)    ☎: +91.80. 6835 7800

Product	<b>Agricultural Knapsack Sprayer (Power) / Agricultural Portable Sprayer (Power) (4-Stroke)</b>	KisanKraft Invoice Date	
Brand	<b>KisanKraft</b>	KisanKraft Invoice No.	
Model	<input type="checkbox"/> KK-KPS-204, <input type="checkbox"/> KK-KPS-274, <input type="checkbox"/> KK-KPS-804, <input type="checkbox"/> KK-PPS-P764, <input type="checkbox"/> KK-PPS-P774		
<b>WARRANTY PERIOD</b>	<b>6-MONTHS</b>	FOR THE SPECIFIED PERIOD FROM THE DATE OF SALE OR DELIVERY WHICHEVER IS EARLIER.	
Dealer's Invoice Date		Dealer's Invoice No.	
Buyer's Info (Name, Address, Phone, etc.):		Dealer's Stamp (Address, Phone, TIN, etc.):	
Buyer's Sign		Dealer's Sign	

**Warranty Policy**

**What is covered:** KisanKraft Limited and its manufacturers warrant this product to be free from defects in material or workmanship. All parts defective in material and workmanship are covered.

This warranty will only cover defects arising under normal usage.

This warranty is limited to repair or replacement by KisanKraft Limited or its manufacturers of such parts as appear to KisanKraft or its manufacturers, upon inspection, to be defective in material and/or workmanship. KisanKraft or its manufacturers make no warranty with respect to items not manufactured or sold by them. No onsite warranty is provided by KisanKraft Limited or its manufacturers. Defective items must be brought/sent to our Authorized Dealer or KisanKraft Limited's office for service.

**What is not covered:** The *warranty shall become null and void* and neither KisanKraft Limited nor any of its manufacturers, nor its authorized dealers assume any responsibility, if the failure was caused by the following:

- (1) Operation of product with incorrect fuel or lubricants, (2) Incorrect usage of machine or misuse, (3) Lack of maintenance, (4) Negligence, (5) Accident or physical damage, (6) Repairs made by unauthorized parties and/or with unauthorized parts, (7) Improper set up, adjustments, tampering or altered products (8) Any modification to the product what-so-ever.

**Important:** (1) Normal maintenance and adjustments to the product is the responsibility of the customer. (2) Normal wear and tear are not covered under warranty. (3) Rubber/plastic parts and consumables such as blades, clutch and clutch-bell, sparkplugs, nylon line, air-filters, fuel-filters, oil seals and gaskets etc. are not covered under the warranty. (4) Electrical Motor, Electrical Parts, Battery Etc. are not covered under the warranty.

**This warranty is null & void, if you fail to register the warranty with KisanKraft by sending the KisanKraft Copy with dealer's stamp.**

🌐: [www.kisankraft.com](http://www.kisankraft.com)    ✉: [info@kisankraft.com](mailto:info@kisankraft.com)    ☎: +91.80. 6835 7800

**Incidental / Consequential Loss:** KisanKraft Limited or its manufacturers will not be liable for general damages, including bodily injuries, or for incidental or consequential damages including, but not limited to, loss of use, loss of profits, loss of production, expense of substitute equipment or other commercial loss or damage.

**Limitation of Liability:** This limited warranty is in lieu of all other express warranties, obligations, or liabilities. Any implied warranties, obligations, or liabilities, including, but not limited to, any implied warranty of merchantability shall be limited in duration to the applicable warranty period. Any action for breach of any warranties hereunder, including, but not limited to, any implied warranty of merchantability must be brought within the applicable warranty period.

**Modifications of Warranty:** No agent, representative, dealer, or employee of KisanKraft Limited or any of its manufacturers has the authority to increase or alter the obligations of this warranty.

**Assignment / Transfer of warranty:** The warranty cannot be assigned and shall not transfer if the product is resold by the first buyer. The above warranties are extended to the first end user (original purchaser), and no warranty is made, nor authorized to be made assignable on resale by the first end user.

**What you must do to obtain limited warranty service:** To obtain performance of any obligation under this warranty for failure during the applicable warranty period, you must deliver the defective product, to the nearest Authorized Dealer, along with proof-of-purchase (invoice/receipt). KisanKraft Limited, its manufacturers and its dealers reserve the right to inspect the claimed defective part(s) to determine if the malfunction is the result of a defect covered by this warranty. Please note that the decision of KisanKraft Limited with respect to any warranty claim is final.

**After-sales Service (Including Warranty):** KisanKraft Limited does not sell directly to consumers. All sales or supplies are made through Authorized Dealers. It is the responsibility of the Authorized Dealer to provide all after-sales service to consumers. Any warranty claim should be raised by dealer to KisanKraft Limited as per warranty policy.

**Jurisdiction:** All disputes are subject to Bangalore court's jurisdiction.

### Notes:

- This purchase is not contingent upon a product demonstration. The purchaser shall satisfy himself with the product, including any product demonstration or verification of any function, before buying. KisanKraft Limited or its authorized dealers, including online sellers, shall not be liable to give any on-site demonstration after purchase of any of the product.
- Any product once used will not be taken back by KisanKraft Limited.
- Warranty and After Sale Services (including but not limited to installation, Demonstration, Repair, Routine Maintenance etc.), should be done through the Authorized Dealer selling this product.
- Dealers should have their own technician to provide After Sales Services to their Customers. KisanKraft Limited provides free training to Authorized Dealer's technicians at KisanKraft Limited's head office, on request from Authorized Dealer.

**This warranty is null & void, if you fail to register the warranty with KisanKraft by sending the KisanKraft Copy with dealer's stamp.**

Product	Agricultural Knapsack Sprayer (Power) / Agricultural Portable Sprayer (Power) (4-Stroke)	KisanKraft Invoice Date	
Brand	<b>KisanKraft</b>	KisanKraft Invoice No.	
Model	<input type="checkbox"/> KK-KPS-204, <input type="checkbox"/> KK-KPS-274, <input type="checkbox"/> KK-KPS-804 <input type="checkbox"/> KK-PPS-P764, <input type="checkbox"/> KK-PPS-P774		
WARRANTY PERIOD	6-Months	FOR THE SPECIFIED PERIOD FROM THE DATE OF SALE OR DELIVERY WHICHEVER IS EARLIER.	
Dealer's Invoice Date		Dealer's Invoice No.	
Buyer's Info (Name, Address, Phone, etc.):		Dealer's Stamp (Address, Phone, TIN, etc.):	
Buyer's Sign		Dealer's Sign	

### Warranty Policy

**What is covered:** KisanKraft Limited and its manufacturers warrant this product to be free from defects in material or workmanship. All parts defective in material and workmanship are covered.

This warranty will only cover defects arising under normal usage.

This warranty is limited to repair or replacement by KisanKraft Limited or its manufacturers of such parts as appear to KisanKraft or its manufacturers, upon inspection, to be defective in material and/or workmanship. KisanKraft or its manufacturers make no warranty with respect to items not manufactured or sold by them. No onsite warranty is provided by KisanKraft Limited or its manufacturers. Defective items must be brought/sent to our Authorized Dealer or KisanKraft Limited's office for service.

**What is not covered:** The warranty shall become null and void and neither KisanKraft Limited nor any of its manufacturers, nor its authorized dealers assumes any responsibility, if the failure was caused by the following:

- (1) Operation of product with incorrect fuel or lubricants, (2) Incorrect usage of machine or misuse, (3) Lack of maintenance, (4) Negligence, (5) Accident or physical damage, (6) Repairs made by unauthorized parties and/or with unauthorized parts, (7) Improper set up, adjustments, tampering or altered products (8) Any modification to the product what-so-ever.

**Important:** (1) Normal maintenance and adjustments to the product is the responsibility of the customer. (2) Normal wear and tear are not covered under warranty. (3) Rubber/plastic parts and consumables such as blades, clutch and clutch-bell, sparkplugs, nylon line, air-filters, fuel-filters, oil seals and gaskets etc. are not covered under the warranty. (4) Electrical Motor, Electrical Parts, Battery Etc. are not covered under the warranty.

**This warranty is null & void, if you fail to register the warranty with KisanKraft by sending the KisanKraft Copy with dealer's stamp.**



**Wide Range of Products for Every Need**



**User Manual**

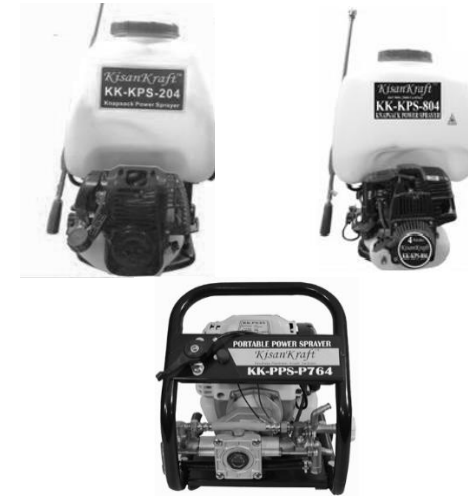

**KisanKraft Limited**

**Warehouse:** 818 3B1 to 818 3B18, Podalakur - Sangam Road, Prabagiripatnam, Podalakur, Nellore - 524345, Andhra Pradesh, INDIA

**Head Office:** Sri Huchhanna Tower, #4, 1<sup>st</sup> Main, 7-A Cross, Maruthi Layout, Dasarahalli, HAF Post, Hebbal, Bangalore 560024, Karnataka, INDIA

- ◆ Bangalore (HO) ◆ Ahmedabad ◆ Bhopal ◆ Bhubaneswar ◆ Coimbatore
- ◆ Guwahati ◆ Hubli ◆ Hyderabad ◆ Jaipur ◆ Karnal
- ◆ Kolkata ◆ Lucknow ◆ Nellore ◆ Pune ◆ Raipur

For more information give **MISSED CALL: 07676065555**



Many of our products have BIS: ISI certification.



Scan the QR code to download **KisanKraft App**

App is available on **Google Play**



Scan the QR code for **KisanKraft Youtube Channel**

**YouTube**

**CONTENTS**

BEFORE GETTING STARTED .....7

SAFETY INSTRUCTIONS.....7

OVERVIEW OF COMPONENTS.....8

ASSEMBLY .....9

OPERATING INSTRUCTIONS ..... 10

MAINTENANCE AND STORAGE ..... 15

TECHNICAL SPECIFICATIONS ..... 16

TROUBLESHOOTING..... 17

POWER SPRAYER- DIAGRAM ..... 19

POWER SPRAYER - PARTS-LIST..... 20

PRESSURE PUMP PARTS - DIAGRAM..... 22

PRESSURE PUMP PARTS-LIST ..... 23

USER MANUAL-4 STROKE PETROL ENGINE..... 25

KisanKraft has a large range of products to serve the farmers. A list of our products is given below:

<p><b>Brush Cutters and Accessories</b></p> <ul style="list-style-type: none"> <li>Brush Cutter/Power Weeder</li> <li>Backpack Brush Cutter</li> <li>Tea Pruner</li> <li>Pole pruner with Engine</li> <li>Reaper Attachment</li> <li>Blades-Circular</li> <li>Blades (2 &amp;3 points)</li> <li>Baffle</li> <li>Nylon Rope</li> <li>Tap &amp; Go</li> </ul> <p><b>Chainsaws</b></p> <ul style="list-style-type: none"> <li>Petrol Chainsaw</li> <li>Electric Chainsaw</li> <li>Chain Sharpening Machine</li> </ul> <p><b>Engines and Water Pumps</b></p> <ul style="list-style-type: none"> <li>Engine –Diesel(Horizontal)</li> <li>Engine –Diesel(Vertical)</li> <li>Engine-Kerosene</li> <li>Water Pump with Petrol Engine</li> <li>Water Pump with Kerosene Engine</li> <li>Water Pump with Diesel Engine</li> </ul> <p><b>Hand Tools</b></p> <ul style="list-style-type: none"> <li>Secateurs</li> <li>Folding Saw</li> <li>Garden Rake</li> <li>Garden Shovel</li> <li>Hedge Shear</li> <li>Lopper</li> <li>Telescopic Hedge Shear</li> <li>Telescopic Lopping Shear</li> <li>Tree Pruner</li> <li>Telescopic Steel Pipe &amp; Fruit Picker Bag</li> <li>Sheep Shear</li> </ul> <p><b>Garden Tools</b></p> <ul style="list-style-type: none"> <li>Electric Pressure Washer</li> <li>Hedge Trimmer</li> <li>Lawn Mower (Electric, Petrol &amp; Manual)</li> <li>Leaf Blower</li> </ul>	<p><b>Cultivators and Accessories</b></p> <ul style="list-style-type: none"> <li>Petrol and Diesel</li> </ul> <p><b>Sprayers and Accessories</b></p> <ul style="list-style-type: none"> <li>Battery Sprayer</li> <li>Portable Power Sprayer</li> <li>Trolley Sprayer</li> <li>Manual Knapsack Sprayer</li> <li>Manual Pressure Sprayer</li> <li>Rose Cans</li> <li>Hose Crimping Machine</li> <li>HTP Sprayer</li> <li>HTP Delivery Hose</li> <li>HTP Hose Reel</li> <li>HTP Stand</li> <li>HTP Gun / Lance( Brass Rod)</li> <li>Knapsack Power Sprayer</li> <li>Mister / Duster / Granule Spreader</li> <li>HTP Sprayer Set with Diesel Engine</li> <li>HTP Sprayer Set with Kerosene Engine</li> <li>Fogging Machine</li> </ul> <p><b>Milking Machine</b></p> <ul style="list-style-type: none"> <li>Wood Shredder</li> <li>Fodder Ensiling Chaff Cutter</li> <li>Fodder Grinder Chaff Cutter</li> <li>Fodder Mini Chaff Cutter</li> </ul> <p><b>Harvester</b></p> <ul style="list-style-type: none"> <li>Maize Sheller</li> <li>Maize Sheller + Dehusker</li> <li>Maize Combine Harvester</li> <li>Onion Digger Carlotta Italy</li> <li>Tea Leaf Harvester</li> <li>Sugarcane Combine Harvester</li> <li>Sugarcane Leaf Stripper</li> </ul> <p><b>Transplanter and Post Hole Digger</b></p> <ul style="list-style-type: none"> <li>Paddy Transplanter (2 &amp; 8 Rows)</li> <li>Transplanter-Vegetable &amp; Tobacco</li> <li>Post Hole Digger(4” to 14” Augers)</li> </ul>
--	--

Sl. No	Description	Qty	Sl. No	Description	Qty
32	Gasket, Valve Cover	1	74	Fuel Cap	1
33	Pin	1	75	Fuel Hose, φ2.38×φ4.75×90	1
34	Rocker Arm Assembly	2	76	Fuel Tube Joint	1
35	Valve Spring Seat	2	77	Fuel Hose, φ2.38×φ4.75×180	2
36	Valve Spring	2	78	Plug	1
37	Push Rod	2	79	Float	1
38	Spark Plug	1	80	Washer, φ5×1.5×φ15	4
39	Cylinder Head	1	81	Float Filter	1
40	Pin	1	82	Damping Pad	3
41	Washer, φ6×1×φ12	1	83	Fuel Tank	1
42	Bolt, M6×10	1			

Product	<b>Agricultural Knapsack Sprayer (Power)/ Agricultural Portable Sprayer (Power) (4-Stroke)</b>	KisanKraft Invoice Date	
Brand	<b>KisanKraft</b>	KisanKraft Invoice No.	
Model	<input type="checkbox"/> KK-KPS-204, <input type="checkbox"/> KK-KPS-274, <input type="checkbox"/> KK-KPS-804 <input type="checkbox"/> KK-PPS-P764, <input type="checkbox"/> KK-PPS-P774		
<b>WARRANTY PERIOD</b>	<b>6-MONTHS</b>	FOR THE SPECIFIED PERIOD FROM THE DATE OF SALE OR DELIVERY WHICHEVER IS EARLIER.	
Dealer's Invoice Date		Dealer's Invoice No.	
Buyer's Info (Name, Address, Phone, etc.):		Dealer's Stamp (Address, Phone, TIN, etc.):	
Buyer's Sign		Dealer's Sign	

**Warranty Policy**

**What is covered:** KisanKraft Limited and its manufacturers warrant this product to be free from defects in material or workmanship. All parts defective in material and workmanship are covered.

This warranty will only cover defects arising under normal usage.

This warranty is limited to repair or replacement by KisanKraft Limited or its manufacturers of such parts as appear to KisanKraft or its manufacturers, upon inspection, to be defective in material and/or workmanship. KisanKraft or its manufacturers make no warranty with respect to items not manufactured or sold by them. No onsite warranty is provided by KisanKraft Limited or its manufacturers. Defective items must be brought/sent to our Authorized Dealer or KisanKraft Limited's office for service.

**What is not covered:** The *warranty shall become null and void* and neither KisanKraft Limited nor any of its manufacturers, nor its authorized dealers assume any responsibility, if the failure was caused by the following:

- (1) Operation of product with incorrect fuel or lubricants, (2) Incorrect usage of machine or misuse, (3) Lack of maintenance, (4) Negligence, (5) Accident or physical damage, (6) Repairs made by unauthorized parties and/or with unauthorized parts, (7) Improper set up, adjustments, tampering or altered products (8) Any modification to the product what-so-ever.

**Important:** (1) Normal maintenance and adjustments to the product is the responsibility of the customer. (2) Normal wear and tear are not covered under warranty. (3) Rubber/plastic parts and consumables such as blades, clutch and clutch-bell, sparkplugs, nylon line, air-filters, fuel-filters, oil seals and gaskets etc. are not covered under the warranty. (4) Electrical Motor, Electrical Parts, Battery Etc. are not covered under the warranty.

**This warranty is null & void, if you fail to register the warranty with KisanKraft by sending the KisanKraft Copy with dealer's stamp.**

**This warranty is null & void, if you fail to register the warranty with KisanKraft by sending the KisanKraft Copy with dealer's stamp.**

**Incidental / Consequential Loss:** KisanKraft Limited or its manufacturers will not be liable for general damages, including bodily injuries, or for incidental or consequential damages including, but not limited to, loss of use, loss of profits, loss of production, expense of substitute equipment or other commercial loss or damage.

**Limitation of Liability:** This limited warranty is in lieu of all other express warranties, obligations, or liabilities. Any implied warranties, obligations, or liabilities, including, but not limited to, any implied warranty of merchantability shall be limited in duration to the applicable warranty period. Any action for breach of any warranties hereunder, including, but not limited to, any implied warranty of merchantability must be brought within the applicable warranty period.

**Modifications of Warranty:** No agent, representative, dealer, or employee of KisanKraft Limited or any of its manufacturers has the authority to increase or alter the obligations of this warranty.

**Assignment / Transfer of warranty:** The warranty cannot be assigned and shall not transfer if the product is resold by the first buyer. The above warranties are extended to the first end user (original purchaser), and no warranty is made, nor authorized to be made assignable on resale by the first end user.

**What you must do to obtain limited warranty service:** To obtain performance of any obligation under this warranty for failure during the applicable warranty period, you must deliver the defective product, to the nearest Authorized Dealer, along with proof-of-purchase (invoice/receipt). KisanKraft Limited, its manufacturers and its dealers reserve the right to inspect the claimed defective part(s) to determine if the malfunction is the result of a defect covered by this warranty. Please note that the decision of KisanKraft Limited with respect to any warranty claim is final.

**After-sales Service (Including Warranty):** KisanKraft Limited does not sell directly to consumers. All sales or supplies are made through Authorized Dealers. It is the responsibility of the Authorized Dealer to provide all after-sales service to consumers. Any warranty claim should be raised by dealer to KisanKraft Limited as per warranty policy.

**Jurisdiction:** All disputes are subject to Bangalore court's jurisdiction.

**Notes:**

- This purchase is not contingent upon a product demonstration. The purchaser shall satisfy himself with the product, including any product demonstration or verification of any function, before buying. KisanKraft Limited or its authorized dealers, including online sellers, shall not be liable to give any on-site demonstration after purchase of any of the product.
- Any product once used will not be taken back by KisanKraft Limited.
- Warranty and After Sale Services (including but not limited to installation, Demonstration, Repair, Routine Maintenance etc.), should be done through the Authorized Dealer selling this product.
- Dealers should have their own technician to provide After Sales Services to their Customers. KisanKraft Limited provides free training to Authorized Dealer's technicians at KisanKraft Limited's head office, on request from Authorized Deale

Sl. No	Description	Qty	Sl. No	Description	Qty
16	Camshaft	1	58	Intake Vavle	1
17	Circlip	2	59	Gasket, Crankcase	1
18	Piston	1	60	Camshaft Pin	1
19	Piston Pin	1	61	Stud, M5x30	4
20	Piston Ring Set	1	62	Crankcase	1
21	Nut, M5	8	63	Flywheel	1
22	Muffler	1	64	Flywheel Cover	1
23	Gasket, Muffler	2	65	Nut, M10x1.25	1
24	Screw, M5x10	1	66	Shroud	1
25	Gasket, Muffler	1	67	Clutch	1
26	Stud, M5x54	2	68	Washer	2
27	Breather Hose	1	69	Clutch Flyweight	2
28	Spray Head Washer	1	70	Spring	1
29	Valve Cover	1	71	Washer	2
30	Oil Block	1	72	Bolt	2
31	Self-tapping Screw, ST4.2x10	1	73	Fuel Tank	1

**This warranty is null & void, if you fail to register the warranty with KisanKraft by sending the KisanKraft Copy with dealer's stamp.**

**This warranty is null & void, if you fail to register the warranty with KisanKraft by sending the KisanKraft Copy with dealer's stamp.**

**ENGINE PARTS-LIST**

Sl. No	Description	Qty	Sl. No	Description	Qty
1	Self-tapping Screw, 4.2x19	3	43	Ignition Module	1
2	Screw, M5x15	12	44	Screw, M5x20	6
3	Recoil Starter	1	45	Gasket, Carburetor Insulator	1
4	Starter Cup	1	46	Bolt, M5x55	2
5	Washer, φ8	1	47	Insulator	1
6	Oil Seal, φ15×φ26×5	2	48	Gasket, Carburetor Insulator	1
7	Screw, M5x28	1	49	Carburetor	1
8	Dipstick	1	50	Throttle Cable	1
9	O-Ring, φ16×3	1	51	Air Filter Assembly	1
10	Crankcase Cover	1	52	Air Filter Base	1
11	Gasket, Crankcase	1	53	Air Filter Element	1
12	Pin, φ4×8	4	54	Air Filter Cover	1
13	Bearing, 6002	1	55	Bolt	1
14	Connecting Rod	1	56	Lower Rocker Arm	2
15	Woodruff Key	1	57	Exhaust Valve	1

**BEFORE GETTING STARTED**

Please read and follow the instructions in this manual before using the machine. The user should be familiar with the safety notices, machine performance, and maintenance, etc. The operation manual will be used later in case of any repair, accessories replacement, and accessories procurement, so preserve it carefully.

**SAFETY INSTRUCTIONS**

- Using this machine with extra high pressure is prohibited ( $\leq 35\text{kgf/cm}^2$ ).
- The rotating parts should have a safety protective device.
- Protective Clothing:

- Wear flange cap.
- Wear dirt/fog-proof glasses.
- Wear gauze mask.
- Wear long gloves.
- Wear coat guarding against poisons.
- Wear boots.



- Spraying towards personnel and working at the downwind position are prohibited.
- Running the machine without water or lubricating oil is prohibited.
- Using special working solutions as strong acid, strong alkali, etc. is prohibited.
- Following personnel should not use the machine:
  - Mentally challenged.
  - Drunk.
  - Under the age of 18 or older people.
  - Person with no knowledge of the machine.
  - Tired person or patient and others who cannot operate the machine normally.
  - A person who has just exercised strenuously or has not slept enough. Women feeding breast milk to the baby or is pregnant.
- Spraying
  - It is fine to carry out an operation during cool weather with little wind. For example, early in the mornings or in the late afternoons as this can reduce the evaporation and drift of chemicals and improve the protective effect.
  - The operator should move windward.
  - If your mouth or eyes are spattered with chemicals, wash them with clean water and then visit a doctor.
  - If the operator has a headache or dizziness, should stop working at once and consult a doctor immediately.

**This warranty is null & void, if you fail to register the warranty with KisanKraft by sending the KisanKraft Copy with dealer's stamp.**

**This warranty is null & void, if you fail to register the warranty with KisanKraft by sending the KisanKraft Copy with dealer's stamp.**

- For the operator's safety, misting/dusting must be carried out strictly according to the instruction of the chemicals and agricultural requirements.
- Spray over, according to pesticide manual to clean out any residual spray mixture in chemical tank.
- After spraying always wash your hands and face thoroughly

## OVERVIEW OF COMPONENTS

### KK-KPS-204 / 274/ 804:

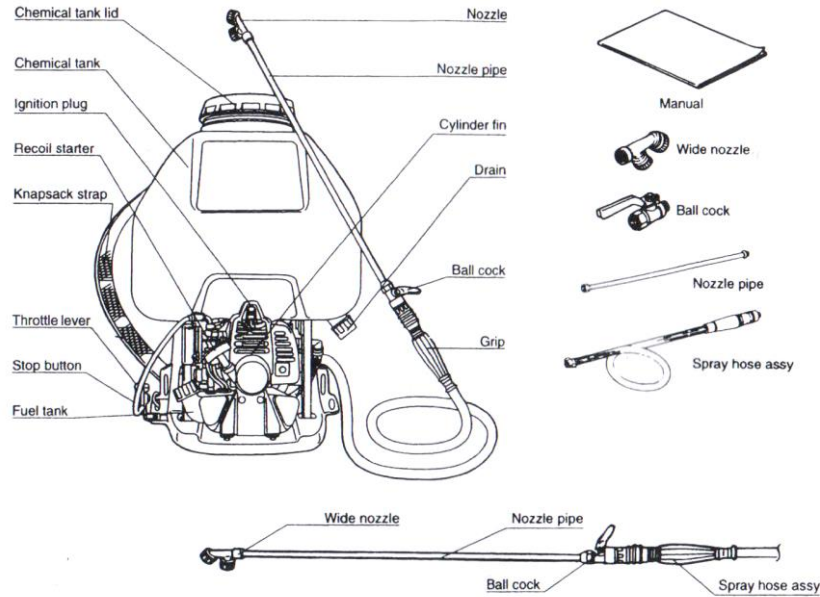

## ENGINE PARTS-DIAGRAM

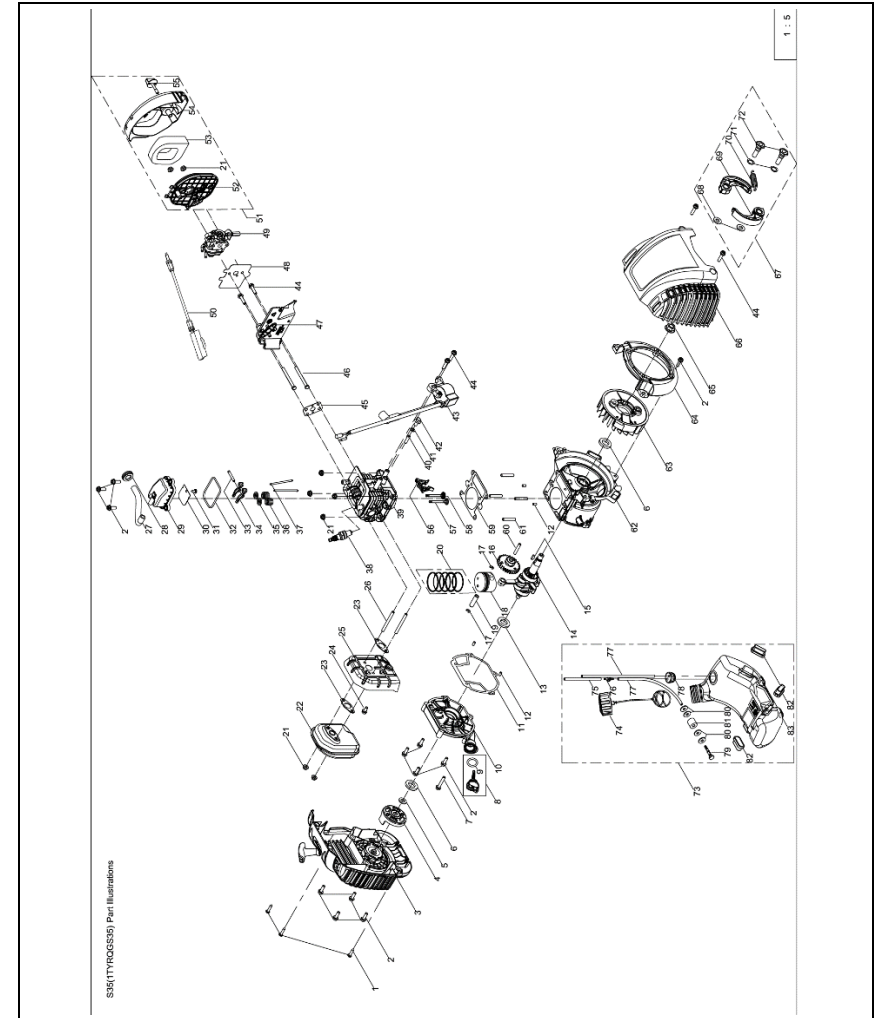

**This warranty is null & void, if you fail to register the warranty with KisanKraft by sending the KisanKraft Copy with dealer's stamp.**

🌐: [www.kisankraft.com](http://www.kisankraft.com)    ✉: [info@kisankraft.com](mailto:info@kisankraft.com)    ☎: +91.80. 6835 7800

**This warranty is null & void, if you fail to register the warranty with KisanKraft by sending the KisanKraft Copy with dealer's stamp.**

🌐: [www.kisankraft.com](http://www.kisankraft.com)    ✉: [info@kisankraft.com](mailto:info@kisankraft.com)    ☎: +91.80. 6835 7800



Situations	Causes	Remedy
insufficient power	The ignition energy is low.	Replace the igniter or the flywheel.
	The valve clearance is excessive	Adjust or replace relevant parts.
	Carbon is deposited on the cylinder head.	Remove the deposited carbon.
Spitting during operation	Blocked oil path of the carburetor	Replace the carburetor.
	Excessive or insufficient clearance of the spark plug	Adjust the clearance
Abnormal sound	Incorrect clearance of the throttle	Replace relevant parts.
	Damaged cam teeth	Replace the cam shaft
Oil leakage of carburetor	Failure of the non-return valve on fuel tank cap	Replace the non-return vent valve of the fuel tank cap.
	Damaged sealing elements of carburetor	Replace them.

Contact the dealer if the gasoline engine still has problems after inspection and repair based on the methods above.

**TRANSPORTATION AND STORAGE**

Handle with care during loading and unloading; laying upside down and inclined placing are strictly prohibited. The damage due to collision is strictly prohibited during transportation, and it is also required to prevent it from exposure to rain. If the engine is to be stored for a long time and will not be used,

1. Place it at a clean, ventilated, dry and damp-proof place;
2. Completely discharge the fuel in the engine (including the engine oil in the oil-bath type air filter);
3. The effective oil seal period should not be less than 6 months under normal conditions of packaging, transport and storage.

**INSTRUCTIONS FOR UNPACKING**

1. During unpacking, the gasoline engine shall be in the upright state; always handle with care!
2. After unpacking, firstly check for the Packing List, certificates, Warranty Card and Operation Manual. Carefully check and verify whether the real products are in compliance against the Packing List.
3. The gasoline engines provided by our company are of high-quality, environment-friendly and of high performance-price ratio. In case of any trouble encountered or any question during your operation, please contact the dealer.

**This warranty is null & void, if you fail to register the warranty with KisanKraft by sending the KisanKraft Copy with dealer's stamp.**

**KK- PPS-P764/P774:**

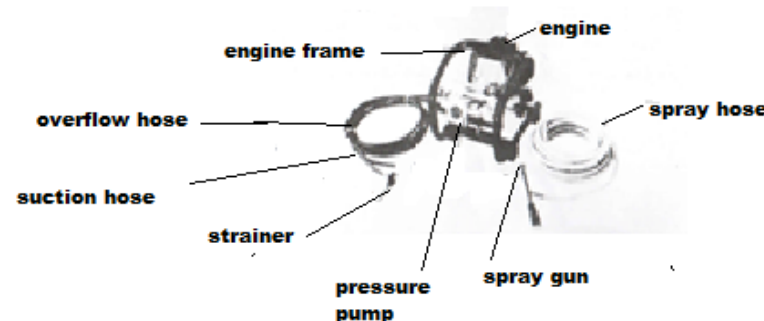

**ASSEMBLY**

**KK-KPS-204 /274/ 804:**

Attach the wide nozzle, the nozzle pipe, the bail cock in an order to the spray hose and connect the other end of the hose to the spray outlet.

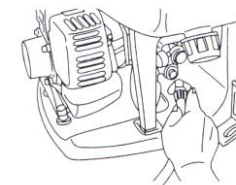

**This warranty is null & void, if you fail to register the warranty with KisanKraft by sending the KisanKraft Copy with dealer's stamp.**

## OPERATING INSTRUCTIONS

### Pre-Operation Preparation:

#### Oiling

1. Make sure that the engine is stopped and cooled.
2. Neither overfill nor spill the fuel on the engine

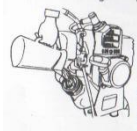

### Dilution of chemicals/Charging the chemical tank (Applicable for KK-KPS-204 / 274 / 804)

**Caution:** Agricultural chemicals are extremely dangerous and must be handled with utmost care. Read the manual for the specific chemical carefully before use.

Dissolve water dispersible powder in a separate container before filling, be sure not to get foreign material into chemicals.

Always fill the chemical tank through the strainer so that contaminants are not mixed into the chemicals.

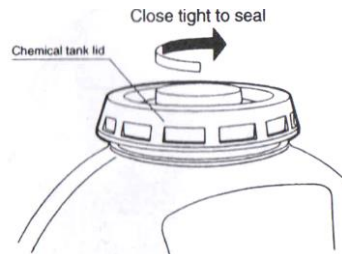
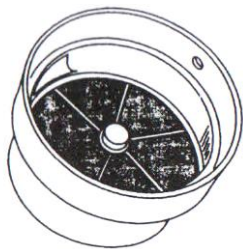

Open the air bleed nozzle, and bleed until the chemical is draining out, and then close the nozzle securely. Before spraying the agrochemical, be sure to put on suitable protective clothing to protect yourself against contact with and breathing it. Observe the following cautions for safe operation:

- a) Be sure to close the chemical tank cover securely.
- b) Check the spray hose and nozzle connections to make sure there are no leakage.
- c) Always stop the engine before refilling the fuel tank or changing the nozzle.
- d) When carrying a full chemical tank, be careful not to lose your balance.

### Starting the Engine (Applicable for both the models):

**Important:** When starting the engine, be sure to fill the chemical tank with pure water or chemical liquid. Never run the engine when the chemical tank is empty.

**This warranty is null & void, if you fail to register the warranty with KisanKraft by sending the KisanKraft Copy with dealer's stamp.**

## TROUBLESHOOTING

### Startup Failure or Difficulty in Startup

Situations	Causes	Remedy	
The spark plug is fireless.	Spark plug	Carbon deposition on the spark plug.	Remove the deposited carbon.
		Excessive or insufficient clearance of the spark plug.	Adjust it to 0.6~0.7mm.
		Damaged insulation of the spark plug	Replace the spark plug.
	Others	Damaged igniter	Replace the igniter.
Weak magnetic force of the flywheel		Replace the flywheel.	
The spark plug cannot generate spark.	Good compression	Too much fuel adsorbed in the cylinder	Screw out the spark plug, dry it and screw it in again.
		Poor fuel, containing water, too dirty	Replace the fuel
	The carburetor oil pump has (not) the ability to pump oil.	Blocked internal oil path	Clean or replace the carburetor.
	Normal oil supply but poor compression	Worn piston ring	Replace the piston ring
		Loose spark plug	Tighten the spark plug.
		Air leakage at the cylinder head, incorrect valve clearance or timing	Removal, re-adjustment or re-installation
	Normal ignition and oil supply	Poor contact between the high-tension line and the spark plug	Remove and reconnect the line properly
		Malfunction or short-circuit of shutdown switch	Replace the shutdown switch

### Abnormal Situations during Operation:

Situations	Causes	Remedy
Rotating speed cannot be increased;	Throttle is close.	Open the throttle.
	The ventilation of the muffler is not smooth	Replace the muffler.
	Moving members are worn	Inspect and replace them.

**This warranty is null & void, if you fail to register the warranty with KisanKraft by sending the KisanKraft Copy with dealer's stamp.**

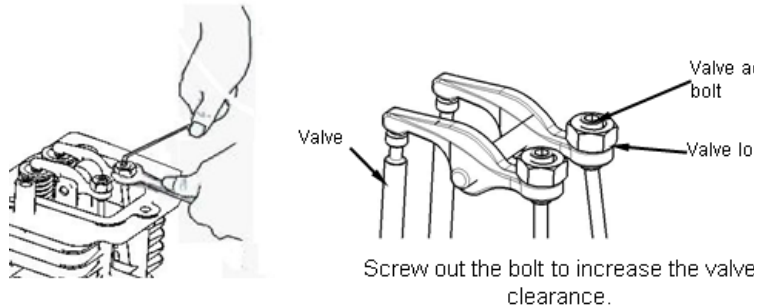

**Maintenance before the Long-Term Shutdown**

If the engine will not be used for a long period of time due to some reasons, one time of maintenance of the engine must be carried out before its shutdown:

1. Screw off the fuel tank cap and pour out the fuel in the fuel tank; actuate the carburetor oil pump to discharge the fuel in the carburetor; then, screw up the fuel tank cap.
2. Screw off the oil rule and discharge the lubricating oil in the gasoline engine based on operating methods
3. Rotate the crankshaft to stop the piston of the gasoline engine at the position of the top dead center, so as to prevent air from getting into the cylinder and rusting the cylinder.
4. Wipe off the oil stain and dust on the external surface with the clean cotton yarn and remove the dirt between the cooling fins, so as to keep the gasoline clean. After cleaning, put the gasoline engine at a clean, dry and ventilated place for storage.
5. Disposal of waste oil: Please store the waste oil in the gasoline engine with a container and deliver it to the local waste oil treatment station for treatment, and do not pour it anywhere.

1. Pump the primer bulb until fuel can be seen flowing through the fuel return line and pull the choke lever to full close. (During hot weather and when the engine is already warmed up, the choke lever may be set to either half open or full open).
2. Set the throttle lever to the middle speed position (not necessarily to maximum).

**KK-KPS-204 / 274 / 804:**

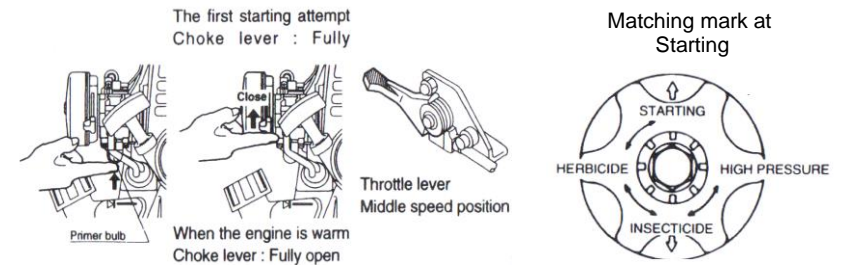

**KK-PPS-P764/P774:**

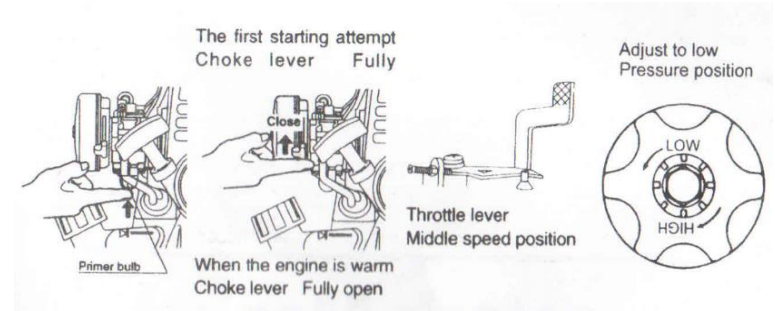

3. Pull the recoil starter lightly 2-3 times.
4. Pull the recoil starter strongly to start the engine.
5. If the engine stops after a few revolutions, set the choke to half open, and pull the recoil starter rope strongly again to restart it.

**Note:** If the engine does not catch even after the starter is pulled several times, set the choke lever to full open and pull the starter rope. Be sure not to pull the starter lever completely out. After the engine starts, open the choke lever slowly, move the throttle lever to the low –speed side, and let the sprayer warm up for 2-3 minutes.

**This warranty is null & void, if you fail to register the warranty with KisanKraft by sending the KisanKraft Copy with dealer’s stamp.**

**This warranty is null & void, if you fail to register the warranty with KisanKraft by sending the KisanKraft Copy with dealer’s stamp.**

**Pull briskly:**

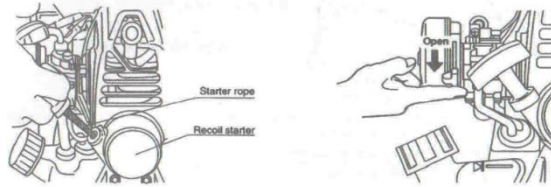

**Operation (KK-KPS-204 / 274/ 804):**

1. Turn the handle of the control valve, and set it to the position for HERBICIDE, INSECTICIDE or HIGH PRESSURE to match the pressure of the operating conditions.

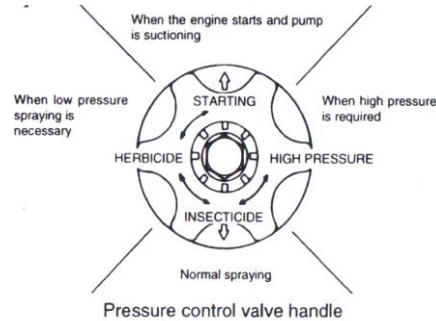

2. Check the spraying conditions and the status of the equipment, then shoulder the equipment and set the throttle lever to the high-speed position.

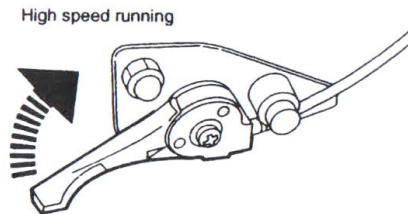

3. When the nozzle cock is opened, chemicals will be atomized as they come out of the nozzle.

**IMPORTANT**

1. When the pressure control valve is changed to INSECTICIDE or HERBICIDE, with the throttle being fully open at HIGH PRESSURE position of pressure control valve handle, the engine speed will become too high, corresponding to the extent of lowered pressure. Therefore, use the equipment with the throttle lever somewhat turned back from the fully opened condition when the equipment is used at the position for INSECTICIDE or HERBICIDE.
2. Be careful of the amount of fuel in the tank, and refill it when it becomes low.

**This warranty is null & void, if you fail to register the warranty with KisanKraft by sending the KisanKraft Copy with dealer's stamp.**



Removal of carbon deposition



Removal of spark plug

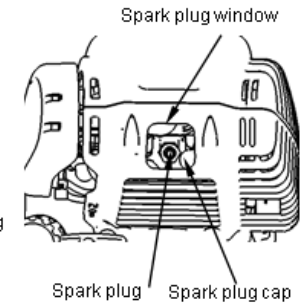

4. Adopt the feeler gauge to measure the clearance of the spark plug. If the adjustment is needed, carry out the adjustment by bending the side electrode.
5. Check whether the washer of the spark plug is in good condition when placing in the spark plug; manually screw it in for 2-3 turns, and then screw it up with the socket special for the spark plug.
6. Reinstall the spark plug cap.

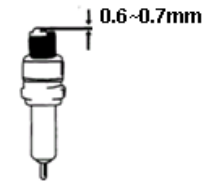

**Warning**

The spark plug must be screwed up, or it may become extremely hot and damage the gasoline engine.

**Adjustment of Valve Clearance:**

Each set of gasoline engine is strictly debugged and inspected by our company. Generally, the engine can get into the normal operation without any adjustment. After it is used for a period of time, you may adjust the gasoline engine based on the following steps:

It is suggested to adopt the standard valve clearance: Inlet valve clearance: 0.05~0.08mm; exhaust valve clearance: 0.08~0.10mm.

- a) Hold the valve clearance adjusting bolt and loose the valve locknut.
- b) Turn the valve clearance adjusting bolt to the specified clearance.
- c) Hold the valve clearance adjusting bolt and screw up the valve locknut.
- d) Re-inspect the valve clearance after screwing up the valve locknut.

**This warranty is null & void, if you fail to register the warranty with KisanKraft by sending the KisanKraft Copy with dealer's stamp.**



air from getting into the carburetor. To avoid any fault of the carburetor, it is required to carry out.

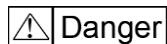

Do not use gasoline or cleaning agent with low ignition point to clean the filtering element of the air filter, or the fire disaster or explosion may occur.

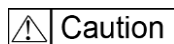

It is strictly prohibited to operate the gasoline engine in the case of not installing the filtering element of the air filter as it may accelerate the wear and damage of the gasoline engine.

1. Screw the bolt of the air filter anticlockwise at the position shown on the figure, so as to take off the air filter cap.  
Upper buckle

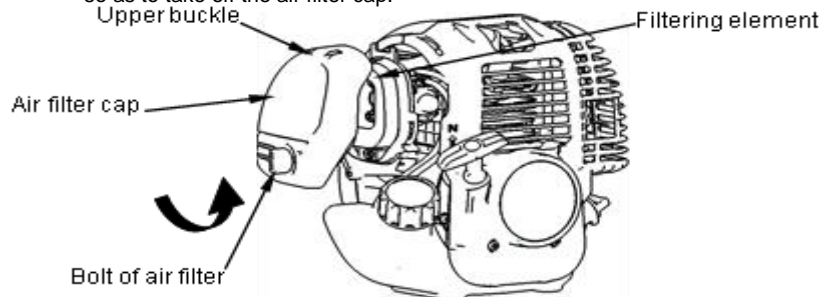

2. Use non-flammable solvent or dissolvent with a high ignition point to clean the filtering element and completely dry it.
3. Use the filtering element to adsorb the clean lubricating oil for the gasoline engine and squeeze out the excessive oil.
4. Reinstall the filtering element of air filter.
5. Install the air filter cap based on the sequence of firstly mounting the buckle and then screwing up the bolt of the air filter clockwise.

### Maintenance of Spark Plug:

To ensure the normal operation of the gasoline, the clearance of the spark plug shall be proper and free of deposit.

1. Dismount the spark cap in the spark plug window and put it aside.
2. Use the socket that is in proper size and special for the spark plug to dismount the spark plug.
3. Visually inspect the spark plug, which shall be replaced in case of obvious breakage and damage or crack or defects on the insulator. The excessive carbon deposition shall be also removed.

**This warranty is null & void, if you fail to register the warranty with KisanKraft by sending the KisanKraft Copy with dealer's stamp.**

### To Stop:

Temporary halt during operation:

1. Close the spray gun and return the throttle lever to low speed.
2. Press the engine stop button.
3. After the engine stops, set the sprayer down and close the fuel cock.

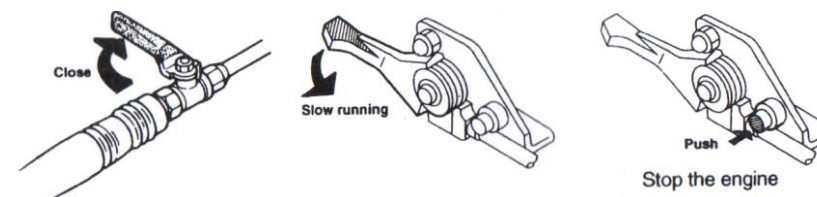

Stopping the sprayer after completing spraying:

1. Remove the chemical tank drain cap, drain off all the chemicals.
2. Fill the chemical tank with clean water, operate the engine, and clean the pump and hose interior by spraying the clean water. Drain off the remaining water through the drain.

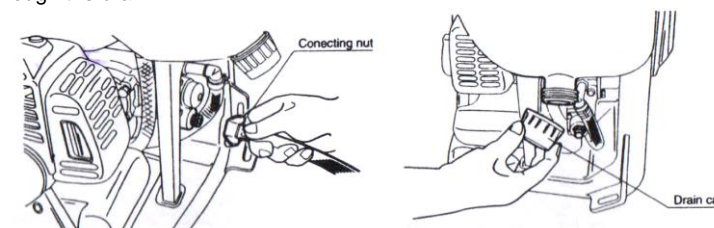

Start the engine at just less than high speed for 15-20 seconds to spray out the water in the spray hose and nozzle. When water stops coming from the nozzle, turn off the engine at once.

### Operation (KK-PPS-P764 / P774):

1. Turn the handle of the control valve to match the pressure of operating conditions.
2. Check spraying conditions and the status of the equipment and set the throttle lever to the high-speed position.

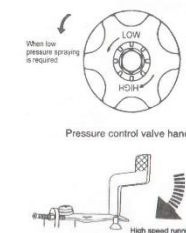

**This warranty is null & void, if you fail to register the warranty with KisanKraft by sending the KisanKraft Copy with dealer's stamp.**

- When the nozzle cock is opened, chemicals will be atomized as they come out of the nozzle.

**IMPORTANT**

- After each 4 continuous working hours, please turn the cap of grease cup for 1 or 2 rounds. This will lubricate the piston and prolong its life.
- After every 100 working hours, please inspect the engine oil level in the pressure pump (you can see it from the oil window of the pump). In case, the oil level is lower than 1/3 position, please remove the oil inlet bolt and add engine oil up to 2/3 position.
- Be careful of the amount of fuel in the tank, and refill it when it becomes low.

**To Stop:**

Temporary halt during operation:

- Close the spray gun and return the throttle lever to low speed.
- Press the engine stop button.
- After the engine stops, close the fuel cock.

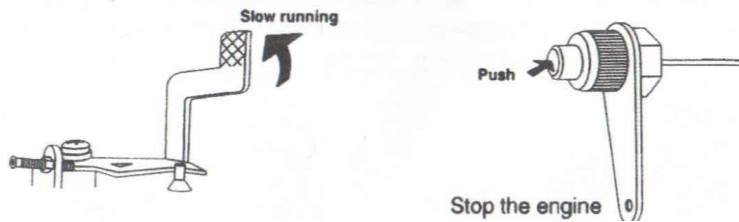

Stopping the sprayer after completing spraying:

- Drain off all the chemical from the chemical tank.
- Fill the chemical tank with clean water, operate the engine, and clean the pump and hose interior by spraying the clean water.  
 Start the engine at just less than high speed for 15-20 seconds to spray out the water in the spray hose and nozzle. When water stops coming from the nozzle, turn off the engine at once.

**This warranty is null & void, if you fail to register the warranty with KisanKraft by sending the KisanKraft Copy with dealer's stamp.**

Item \ Maintenance cycle		Each time of use	Every 1 month or 10 hours	Every 3 months or 25 hours	Every 6 months or 50 hours	Every 1 year or 100 hours	Every 2 years or 300 hours
		Idle speed	Check and adjustment				
Valve clearance	Check and adjustment					■b	
Combustion chamber	Cleaning	300 hours later					
Fuel screen	Check					■	
Fuel tank	Check					■	
Fuel pipe	Check	Every 2 years (replacement if necessary)					

**Note:**

- Increase the maintenance interval if it is used in the dusty area.
- The maintenance of these items shall be conducted by maintenance service stations specially authorized by our company, unless the users have appropriate tools and the maintenance ability.
- With respect to those gasoline engines for commercial purposes and under long-term operation, their maintenance intervals shall be correctly determined.

**Replacement of Lubricating Oil:**

It is suggested to release the oil when heating the engine, so as to ensure the quick and complete release of the lubricating oil.

- Check whether the fuel tank cap is screwed up.
- Dismount the oil rule and incline the gasoline engine to the neck where the lubricating oil is applied, so as to release the oil to an appropriate container.
- Fill in the recommended lubricating oil and check the oil level.
- Reinstall the oil rule:** In case of lubricating oil overflowing, make sure to wipe off the oil. Wash hands with soap water or detergent after contacting the lubricating oil, and then wash hands with clean water.

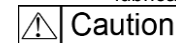

Please dispose the waste lubricating oil and containers with methods in compliance with environmental protection requirements. It is suggested to store the waste lubricating oil into a sealed container and deliver it to the local waste oil recycle bin for treatment. Do not throw it into the dustbin or pour it on the ground or into the drainage ditch.

**Maintenance of Air Filter**

The function of the air filter is to filtrate impurities and dust in the air so as to allow the clean air to flow into the combustion chamber for combustion. The dirty air filter will prevent the

**This warranty is null & void, if you fail to register the warranty with KisanKraft by sending the KisanKraft Copy with dealer's stamp.**

### ⚠ Caution

Under normal circumstances, it is strictly prohibited to directly shut the engine down in the case of no load off.

### ⚠ Warning

For the sake of your health, please be far away from the muffler and do not directly face the exhaust port during operation of the gasoline engine. Pay attention to the unusual change of the gasoline during its operation. Immediately shut down the engine in case of abnormal sound, severe vibration, unstable rotating speed, blasting and other adverse phenomena of the gasoline engine.

## REPAIR AND MAINTENANCE

### Maintenance Schedule:

The regular inspection and adjustment must be carried out to ensure the gasoline engine maintains its excellent performance. The regular maintenance also ensures a long-term service life. See the following table for regular maintenance cycle.

Item	Maintenance cycle	Maintenance cycle					
		Each time of use	Every 1 month or 10 hours	Every 3 months or 25 hours	Every 6 months or 50 hours	Every 1 year or 100 hours	Every 2 years or 300 hours
Lubricating oil	Check the oil level	■					
	Replacement		■		■		
Air filter	Check	■					
	Cleaning			■a			
Spark plug	Check and adjustment					■	
	Replacement						■
Spark extinguisher (optional)	Cleaning					■	
Cooling fin	Inspection				■		
Bolt, nut and other fasteners	Check (screwing up if necessary)						
Clutch	Inspection				■b		

## MAINTENANCE AND STORAGE

(Applicable for both the models)

### Cleaning the air cleaner:

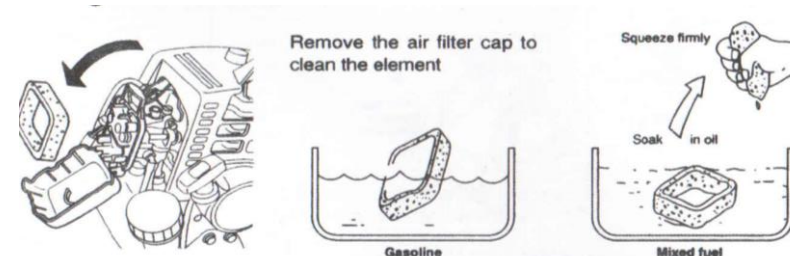

### Plug:

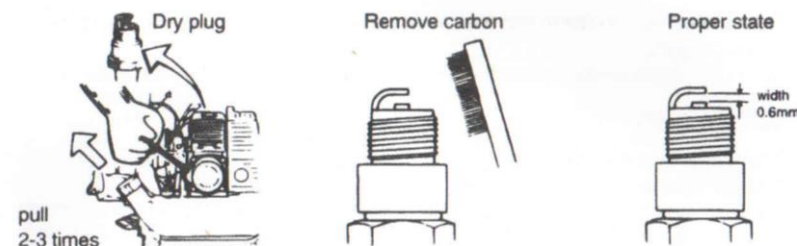

### Storage:

After using the sprayer for the season, store it until the next season of use as follows:

1. Drain off all fuel from the fuel tank and the carburetor.
2. Remove the spark plug and coat the cylinder with a small amount of oil. Pull the recoil starter lightly 2-3 times to spread the oil over the cylinder completely as shown in the figure below.

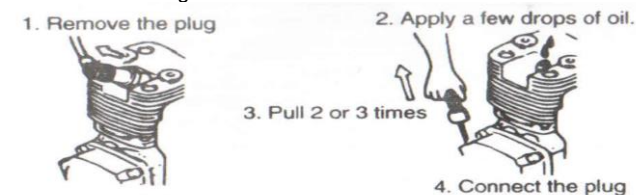

This warranty is null & void, if you fail to register the warranty with KisanKraft by sending the KisanKraft Copy with dealer's stamp.

This warranty is null & void, if you fail to register the warranty with KisanKraft by sending the KisanKraft Copy with dealer's stamp.

3. Pull the recoil starter out slightly and stop it in place where you feel the pull start (compression starts).
4. Clean the entire sprayer completely, cover it so it does not accumulate dirt and dust, and store it in a dry, cool location.

**TECHNICAL SPECIFICATIONS**

Model	KK-KPS-204	KK-KPS-274	KK-KPS-804	KK-PPS-P764	KK-PPS-P-P774
HP	0.7 kW (1 hp)				
CC	31.1	31	21	31	26
speed	6500	6500	6500	6500	6500
Engine Type	4 – stroke				
RPM/Output Pressure	1800 (Pump RPM)/ 20-35bar				
Fuel Used	Petrol				
Fuel Tank Capacity	600 ml			600 ml	
Fuel Consumption	650 ml/hr.			500 ml/hr.	
Liquid Output	7-8 L/min			9 L/min	8-9 L/min
Chemical tank capacity(L)	20		25	N/A	
Oil (Mixing)	For Engine 100 ml (20w 40 Grade)				
Weight of the Machine	10 kg	9.7 kg	11.5 kg	10 kg	
Consumption/Out Put Capacity	500-600 ml/hour (Engine) & 420 Liter/hour (Output)				

Note: Specification can be changed without notice.

6. In case of using the gasoline engine in the plateau region, the air and fuel mixture of the carburetor in the normal state will be too dense, which will reduce the running performance of the gasoline engine and increase the fuel consumption. Thus, the carburetor shall be replaced with a special one for use in the plateau region.
7. With the increase of the elevation, the power of the gasoline engine will have some decline.

Handle of choke valve

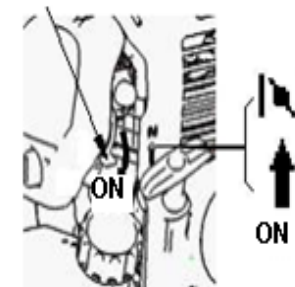

**Operation:**

When preheating the gasoline engine, gradually move the handle of the choke valve to the "OPEN" position. Then, adjust the handle of the throttle valve upward and set it at the position of the required running speed of the engine.

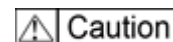
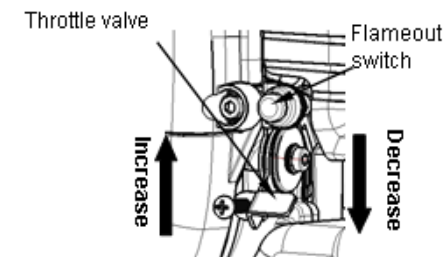

To give full play to the product performance, it is suggested to run the gasoline engine for about 15 minutes in the low-speed state if the engine is used for the first time. Heat the engine for 3-5 minutes and then get it into the working state every time when it is to be used.

**Shutdown**

Directly press down the stop switch or pull off the spark plug cap in case of shutdown in an emergency. Generally, conduct the operation based on the following steps:

1. Release the load firstly; then press down the handle of the throttle valve to reduce the rotating speed of the gasoline engine.
2. Press down the stop switch after 2-3 minutes of no-load running.

**This warranty is null & void, if you fail to register the warranty with KisanKraft by sending the KisanKraft Copy with dealer's stamp.**

**This warranty is null & void, if you fail to register the warranty with KisanKraft by sending the KisanKraft Copy with dealer's stamp.**



**Startup of Gasoline Engine**

1. Forcibly press the oil pump until the fuel in the fuel pipe (transparent oil pipe) can be seen

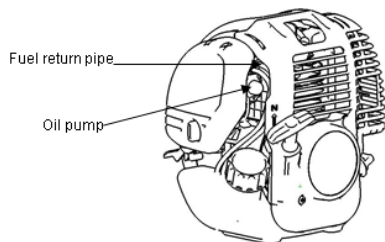

2. Pull the choke valve to the "OFF" position and return

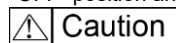

Do not use the choke valve when the gasoline engine is hot or in the high-temperature state.

**Handle of choke valve**

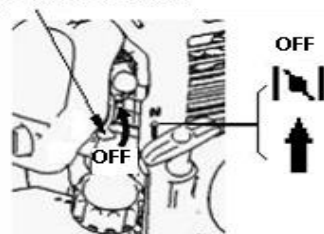

**Startup:**

3. Grasp the starter handle and slowly pull until you feel the resistance, then firmly pull it outwards.

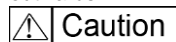

4. It is required to slowly lay back the handle along the resilience of the starter rope rather than abruptly release the handle and allow it to rebound and strike the gasoline engine, which will damage the starter.

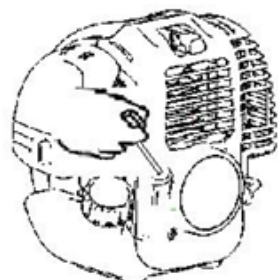

5. It is required to quickly pull the starter, or the electrode of the spark plug cannot spark, which will consequently result in the starting failure.

**TROUBLESHOOTING**

**Pump:**

Trouble	Cause	Remedy
No Suction	Hose is Loose	Tighten the hose carefully
	Suction hose is clogged with chemicals.	Disassemble and clean the hose.
	Worn piston packing.	Replace with a new piston
	Foreign object in valve parts.	Disassemble and clean the valve.
Poor spray quality	Worn piston packing	Replace with a new piston
	Flaw in cylinder inner surface	Replace with a new cylinder
	Flaw in exhaust valve	Replace with a new valve
	Worn pressure control valve handle	Replace with a new handle
	Foreign object in valve parts	Replace with a new
	Worn nozzle hole.	Replace with a new nozzle.
	Too many nozzles attached	Reduce number of nozzles or replace with nozzle of smaller holes.

**When engine fails to start:**

Trouble	Cause	Remedy	
There is fuel, but spark plugs fail to ignite.	Drawing too much fuel	Tuning the carburetor	
	There is power at the terminal.	Faulty spark plug gap.	Adjust the spark plug gap
		Faulty spark plug insulation.	Replace the spark plug
	No power at the terminal	Faulty TCI unit or broken wire	Replace the ignition coil.
A break or short in the ignition coil.			
There is fuel and spark plug ignite	Compression is good	Bad Mixture	Adjust the carburetor
	Compression is bad	Faulty packing	Tighten the spark plug
		Spark plugs not tightened properly	Tighten the spark plug
No fuel in the carburetor		Piston rings are sticking	Replace the piston ring
		No fuel in the tank	Fill the tank with fuel
		Fuel valve is faulty, or fuel tank air vent is plugged.	Clear air vent hole
	Lines are bent	Replace lines	

**This warranty is null & void, if you fail to register the warranty with KisanKraft by sending the KisanKraft Copy with dealer's stamp.**

**This warranty is null & void, if you fail to register the warranty with KisanKraft by sending the KisanKraft Copy with dealer's stamp.**

**Engine fails to run smooth:**

Trouble		Cause	Remedy
No power	Compression is good and there is no misfire	Air cleaner element is plugged up.	Clean or replace air cleaner if necessary
		Air has entered fuel line joints.	Clear the fuel line
		Faulty choke lever	Replace choke lever
	Compression is bad	Carbon builds up on cylinder muffler.	Clean the muffler
		Burnt spark plugs	Replace the spark plug
		Short in cable	Replace the cable
Engine overheated	Bad mixture or piston ring wear.	Replace the piston ring	
	Marks on cylinder. Cracks in the piston head	Replace the piston	
	Fuel is too low (mixture is too thin).	Engine over oiling.	
	Faulty mixture, not enough mixture.	Clear the lines	
	Carbon piled up, overloaded operation.	Clean the carbon	
Inaccurate explosion	Faulty spark plugs.	Replace the spark plugs	
	Plugged cylinder or coolant lines	Clean the coolant lines	
	Carburetor not adjusted properly.	Adjust the carburetor gap properly	
Engine doesn't sound right	Faulty spark plugs.	Replace the spark plug	
	Faulty magneto or internal short	Replace the magnet	
	Overheated cylinders	Replace the cylinder	
	Overload operation	Right quantities of petrol and oil should be mixed to enable proper lubrication	
Slow acceleration	Faulty mixture or incorrect ratio	Replace the necessary spares/contact service person	
	Internal engine damage	Adjust the carburetor gap properly	
	Carburetor not adjusted properly or faulty compression	Use good quality gasoline-oil mixture.	
	Poor gasoline oil quality	Clean the carbon	
	Carbon pile up		

**Recommended fuel**

It is recommended to use the unleaded gasoline with an octane value of 90# or higher, so as to reduce the carbon deposition in the combustion chamber. Do not use the out-of-date or polluted gasoline or the fuel mixture of engine oil and gasoline. It is also required to keep the water or dust from getting into the fuel tank. Sometimes, there will be spark knock sound or the bang-bang noise in case of overload operation, which is normal. If the continuous spark knock sound can still be heard when the gasoline engine operates under the normal load, it is suggested to replace the gasoline with other brands; after then, if the sound still exists, please consult the specially authorized service shop for solution

**Caution**

- Gasoline is highly flammable and can explode under some circumstance.
- Refill the gasoline in the well-ventilated environment and shut down the engine during refueling; no smoking at the refueling place and no open fire and spark at the gasoline storing place is permitted.
- The fuel tank shall not be overfilled (The fuel level shall not be higher than the neck of the oil filler); inspect whether the fuel tank cap is properly covered after the refueling is completed.
- Be careful not to spill fuel when adding the fuel. Spilled fuel or vapor of the overflowing fuel may result in fire. Wipe up any spilled fuel without delay.
- Do not allow children to touch it. Capacity of fuel tank:0.6L

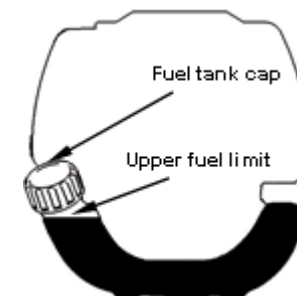

**Gasoline containing alcohol**

If the gasoline containing alcohol (alcoholic gasoline) is adopted, the ethanol content in the alcoholic gasoline shall not exceed 10%. Do not use the alcoholic gasoline where the methanol is free of combustion improver and corrosion inhibitor. Though the methanol does contain combustion improver and corrosion inhibitor, the methanol content in the alcoholic gasoline shall not exceed 5%.

**This warranty is null & void, if you fail to register the warranty with KisanKraft by sending the KisanKraft Copy with dealer's stamp.**

🌐: www.kisankraft.com    ✉: info@kisankraft.com    ☎: +91.80. 6835 7800

**This warranty is null & void, if you fail to register the warranty with KisanKraft by sending the KisanKraft Copy with dealer's stamp.**

🌐: www.kisankraft.com    ✉: info@kisankraft.com    ☎: +91.80. 6835 7800

**OPERATING INSTRUCTIONS**

**POWER SPRAYER- DIAGRAM**

**Preparation and Check Prior to Operation**

**Caution**

The gasoline engine is not filled with engine oil before it is delivered from the factory. Please fill it with engine oil firstly

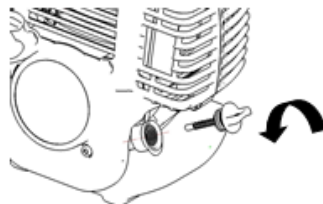

**Check the lubricating oil level**

1. Shut down the gasoline engine and place it at horizontal level.
2. Dismount the engine oil rule and check the oil level, which shall be up to the oil filler.
3. If the oil level is low, fill the recommended lubricating oil to the oil filler
4. Remount the oil rule.

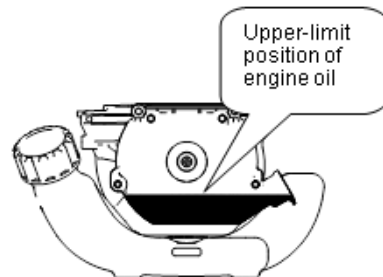

**Caution**

1. The filling volume of lubricating oil for the gasoline engine is 75ml. Due to the small capacity, it is required to slowly fill the oil to avoid overflow or spilling.
2. Check the lubricating oil level of the gasoline engine at intervals of 10 hours and fill it up to the oil filler if the gasoline engine is required to continuously operate for above 10 hours.
3. Users shall use engine oil of different brands under different ambient temperatures.
4. The use of the lubricating oil free of cleaning agent or the lubricating oil for the two-stroke engine will shorten the service life of the gasoline engine. The operating temperature range recommended for the gasoline engine is -5°C~40°C.

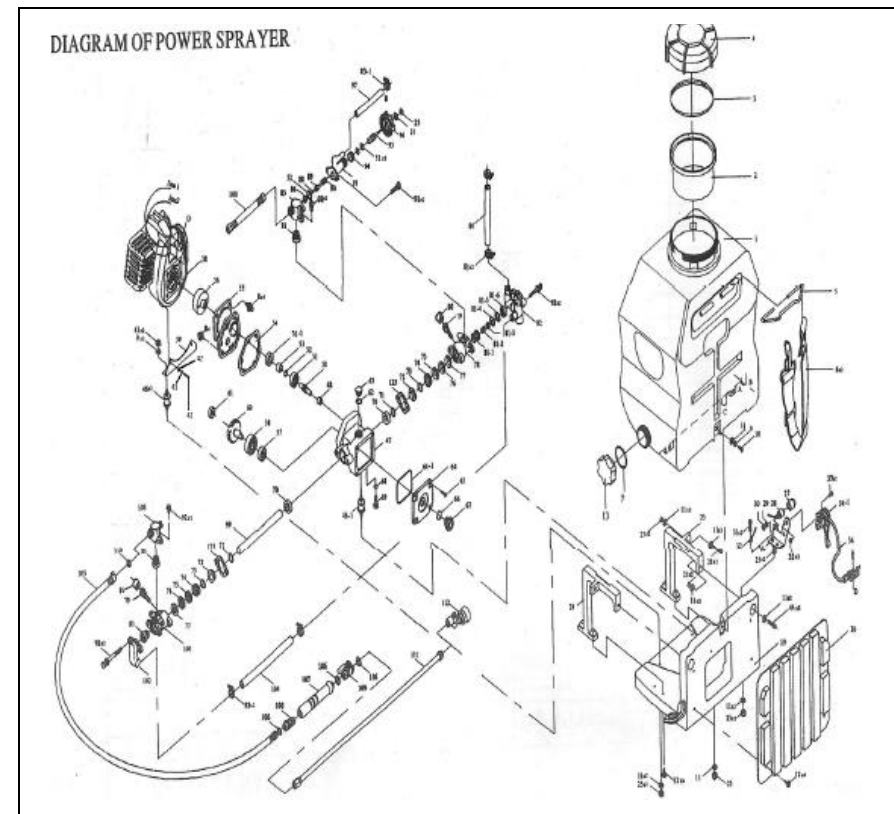
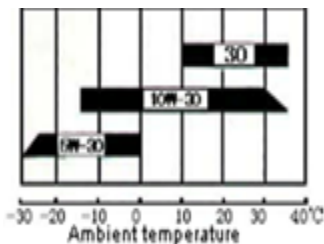

**This warranty is null & void, if you fail to register the warranty with KisanKraft by sending the KisanKraft Copy with dealer's stamp.**

**This warranty is null & void, if you fail to register the warranty with KisanKraft by sending the KisanKraft Copy with dealer's stamp.**

**POWER SPRAYER - PARTS-LIST**

Part no.	Part name (body)	Part no.	Part name (body)
1.	Chemical Tank	62	'O' Ring - Oil Inlet Bolt
2.	Strainer (Big)-Chemical Tank	63	Oil Inlet Bolt
3.	Gasket-Chemical Tank Lid	64	Crank Case Cover
4.	Chemical Tank Lid	64-1	'O' Ring - Crank Case Cover
5.	Belt Holder	65	Screw - Crank Case Cover
6.	Shoulder Belt	66	'O' Ring - Oil Glass
7.	Gasket -Drain Cap	67	Oil Glass
8.	Screw M6x18-Hex	68	'O' Ring - Oil Drain Bolt
9.	Washer 6-Spring	69	Oil Drain Bolt
10.	S T Screw	70	Oil Seal - 18x28x8
11.	Washer 6-Plain	70-1	Oil Seal - 18x28x8
12.	Screw M6x25-Star	71	'O' ring - Plunger
13.	Drain Cap-Chemical Tank	72	Adjusting Ring
19.	Frame	73	Grease Seal
20.	Rubber Pad	74	Grease Ring
21.	Screw M6x18-Hex	75	V - Packing
23.	Right Stand	76	N/A
24.	Left Stand	77	V - Packing Seat
25.	Nut M6-Nylon	78	Cylinder - Right
26.	Fixed Plate-Flex Accelerator	79+80	Grease Cup
28.	Switch On/Off	81	Valve Assembly
30.	Nut M8-Hex	82	Suction Chamber - Right
31.	Screw M6x18-Hex	83	Clip - L
32.	Cord Comp-Wire	83-1	Clip - S
33.	N/A	84	Suction Hose - 5"
34.	Throttle Cable	85	Outlet Chamber - Right

**TECHNICAL SPECIFICATIONS**

Name	Specification
Cylinder bore x stroke	39x26
Displacement: mL	31.1
Compression ratio	8.3:1
Fuel consumption: g/(kWh)	≤480
Lubricating oil consumption rate: g/(kWh)	≤6.8
Idle speed: (rpm)	2800±150
Valve clearance	Intake valve: 0.05—0.08mm Exhaust valve: 0.08—0.10mm
Noise limitation	The noise complies with requirements of GB15739-1995.
	The test shall be in accordance with GB/T1859-2000.
Maximum power and rotating speed: kW/(rpm)	0.7/6500
Maximum torque and rotating speed: Nm. /(rpm)	1.1/5000
Modes of ignition and startup	Inductive ignition, recoil-type startup

**This warranty is null & void, if you fail to register the warranty with KisanKraft by sending the KisanKraft Copy with dealer's stamp.**

 www.kisankraft.com   
  info@kisankraft.com   
  +91.80. 6835 7800

**This warranty is null & void, if you fail to register the warranty with KisanKraft by sending the KisanKraft Copy with dealer's stamp.**

 www.kisankraft.com   
  info@kisankraft.com   
  +91.80. 6835 7800



- If it is operated based on the operating manual, this gasoline engine can provide the safe and reliable operation as designed. Please carefully read and understand this instruction manual before operating the engine, or it may cause personal injury or equipment damage.



- Do not touch the muffler during operation and shutdown of the gasoline engine as it is very hot. Place the gasoline engine in a room after it cools down.



- As the exhaust system of the gasoline engine is very hot during its operation and at the time of shutdown. Please pay attention to the warning label on the gasoline engine to avoid being burnt.



- As the gasoline is inflammable and explosive, please make sure to refuel at a ventilated place, shut down the gasoline engine before refueling and be far away from cigarettes and spark; the overflowing gasoline shall be wiped off immediately.



- Do not use it indoors and make sure to have enough ventilation as the exhausted air contains carbon monoxide.

### INSTALLATION DIMENSION

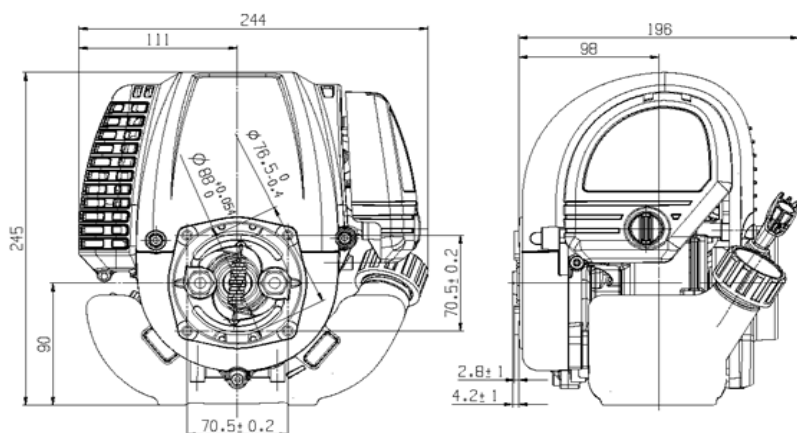

This warranty is null & void, if you fail to register the warranty with KisanKraft by sending the KisanKraft Copy with dealer's stamp.

Part no.	Part name (body)	Part no.	Part name (body)
34-1	Flex Accelerator	86	Steel Ball Seat
35	Nut M6-Nylon	88	Steel Ball
37	Screw M6x18-Hex	89	Pressure Valve Rod
38	N/A	90	Relief Valve Spring
39	Engine Stand	91	Screw M6x18-Hex
40	Washer 5-Plain	92	Screw M6x18-Hex
41	Washer 5-Spring	93	Relief valve Body
42	Screw M5x25-Allen	94	Brass Nut-Relief Valve
43	Nut M6-Nylon	95	Relief Valve Screw
46	Joint-S	96	Pressure Adjusting Knob
46-1	Joint - L	97	Overflow Hose-5"
47	Crank Case	98	Screw M6x75-Hex
48	Needle Bearing-For Shaft	99	Plunger
50	Shaft	100	High Pressure Hose -Small
51	Bearing - 6201	101	Cylinder-Left
52	'O' Ring - Steel Pipe	102	Suction Chamber-Left
53	Steel Pipe	103	Outlet Chamber-Left
54	Gasket - Drum Case	104	Suction Hose-9"
55	Drum Case	105	High Pressure Hose -Big
56	Clutch Drum	106	Packing -Handle/Spray Rod
57	Bearing - 6200	107	Hose Pipe Handle
58	Bearing - 6203	108	N/A
59	N/A	109	Ball Cock-One Way
60	Gear	110	Packing-High Pressure Hose
61	Bearing - 608	111	Spray Rod
123	Fixed Plane	115	Nozzle (4 Hole)

This warranty is null & void, if you fail to register the warranty with KisanKraft by sending the KisanKraft Copy with dealer's stamp.



**PRESSURE PUMP PARTS - DIAGRAM**

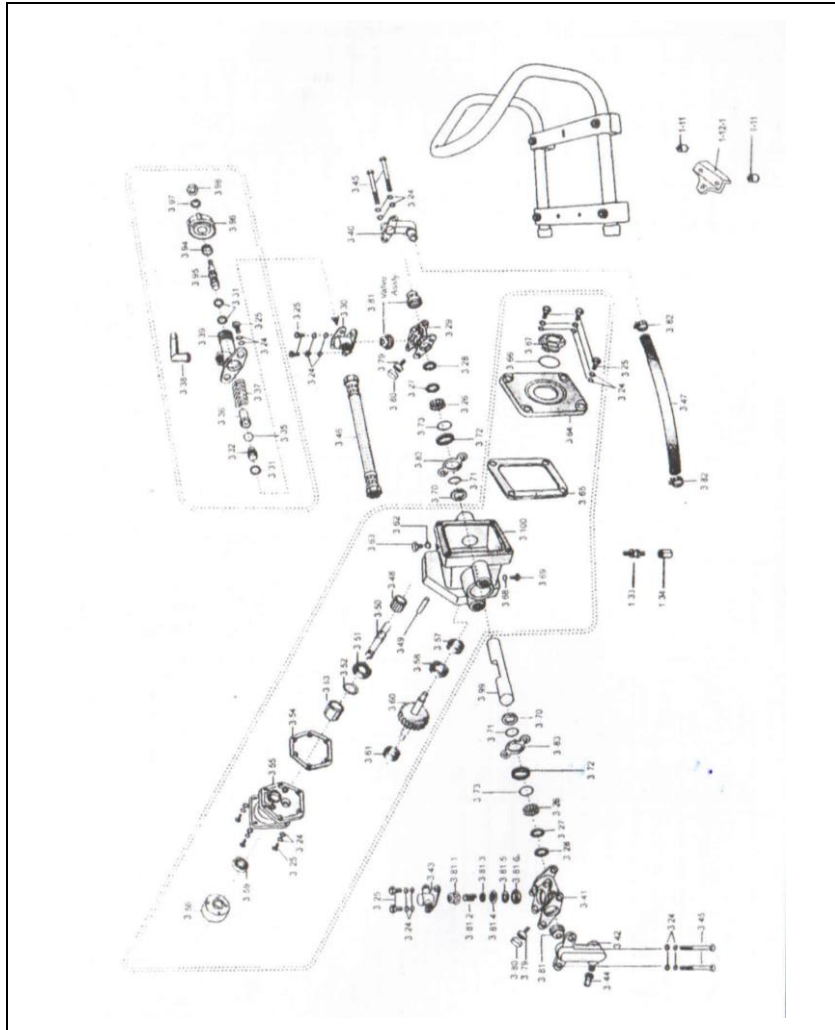

3. It is not allowed to place inflammable, explosive, and other dangerous articles around the gasoline, so as to avoid the fire hazard.
4. The workplace shall be of smooth ventilation and be above 10m away from the combustion source.
5. The engine must be shut down when adding fuel or lubricating oil.
6. Smoking is strictly prohibited in the course of refueling, and overflowing of gasoline is not allowed; if it overflows due to carelessness, the oil stain must be completely cleaned prior to the startup of the gasoline engine.
7. To prevent your gasoline engine from being damaged, please do not start up the engine when the lubricating oil is not applied or when the applied lubricating oil is insufficient.
8. Do not operate the gasoline engine when you are not quite sure or under the influence of alcohol. Otherwise injury may result.
9. **Caution** Prolonged or repeated exposure to gasoline or engine oil may cause skin carcinoma, even though this possibility is very low. Wash hand thoroughly with soap and water after handling gasoline and engine oil
10. **Caution** We recommend that the users place the used gasoline engine oil into closed containers and deliver containers to the waste treatment yard or reclamation depots.
11. Don not allow used gasoline and engine oil to spill on ground or be drained into waste water piping or sewers.
12. Keep the gasoline engine hot and in horizontal position to drain engine oil rapidly and completely.
13. For the sake of the safety of your own and the others, please pay special attention to the following safety signs.

**This warranty is null & void, if you fail to register the warranty with KisanKraft by sending the KisanKraft Copy with dealer's stamp.**

www.kisankraft.com    info@kisankraft.com    +91.80. 6835 7800

**This warranty is null & void, if you fail to register the warranty with KisanKraft by sending the KisanKraft Copy with dealer's stamp.**

www.kisankraft.com    info@kisankraft.com    +91.80. 6835 7800

emission. There are diversified types of power take-off ends, and our perfect after-sales service system ensures that you will have a most trouble-free and satisfying gasoline engine.

This series of gasoline engines are of single-cylinder, four-stroke, small, light in weight and compact in structure, and adopt the forced air cooling, overhead valve, inductive ignition and recoil-type hand-operated startup.

This manual contains the latest information on operation and maintenance of the engine (the illustration in the manual is indicative and only for reference). As our products are constantly in the process of further improvement and development, they are subject to improvement or alteration without notice.

In case that the gasoline engine is resold, this instruction manual shall be regarded as an integral part of the gasoline engine and delivered with it.

**Warning** Please read this manual thoroughly before operating the engine and observe these instructions contained in this manual strictly. Our company's safe and reliable gasoline engines can operate safely and reliably and not result in personal injury or equipment damage.

Failure to comply with these instructions will result in serious injury or equipment damage.

### STRUCTURAL DIAGRAM

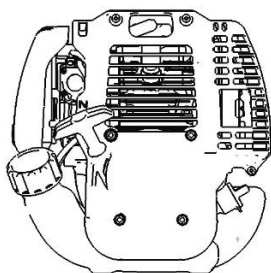

### WORKING PRINCIPLE:

The fuel is burned in a single cylinder to drive the piston for reciprocating motion, by which the chemical energy of the fuel is converted into mechanical energy; sequentially, the power output is realized.

### SAFETY INSTRUCTIONS

1. The gasoline engine must be operated by personnel with certain professional knowledge, and the independent operation by non-professional personnel is strictly prohibited.
2. Keep the gasoline beyond the reach of children.

**This warranty is null & void, if you fail to register the warranty with KisanKraft by sending the KisanKraft Copy with dealer's stamp.**

### PRESSURE PUMP PARTS-LIST

Part no.	Part name (body)	Part no.	Part name (body)
1-11	Shake- proof plug 6 mm	3-57	Ball bearing 608
1-12-1	Fixing bracket	3-58	Ball bearing 6203
3-24	Washer	3-59	Oil seal for upper case
3-25	Hex bolt m6x16	3-60	Gear shaft
3-26	Grease ring	3-61	Ball bearing 608
3-27	V-packing	3-62	O-ring 12x1.8
3-28	Adjusting ring	3-63	Oil inlet bolt
3-29	Right pressure chamber	3-64	Gear box cover
3-30	Right delivery chamber	3-65	O-ring, gear box cover
3-31	O-ring 10x1.8	3-66	O-ring, oil window 31x 3
3-32	Valve seat	3-67	Oil window
1-33	Shake- proof plug 6 mm	3-68	O-ring 6.3x1.8
1-34	Pump bracket	3-69	Oil outlet bolt
3-35	Ball valve	3-70	Oil seal for piston
3-36	Spring seat	3-71	O-ring for piston 17x1.8
3-37	Spring	3-72	Packing seat
3-38	Overflow joint	3-73	O-ring 18x2.65
3-39	Pressure regulating valve body	3-79	Grease cup
3-40	Right suction chamber	3-80	Cap for grease cup
3-41	Left pressure chamber	3-81	Valve assembly
3-42	Left suction chamber	3-81-1	Valve cage
3-43	Left delivery chamber	3-81-2	Valve spring
3-44	Suction joint	3-81-3	Valve plug
3-45	Hex bolt m6x73	3-81-4	Valve seat
3-46	Pump delivery hose assembly	3-81-5	Valve ring

**This warranty is null & void, if you fail to register the warranty with KisanKraft by sending the KisanKraft Copy with dealer's stamp.**

Part no.	Part name (body)	Part no.	Part name (body)
3-47	Pump suction hose	3-81-6	Valve packaging
3-48	Roller bearing	3-82	Hose clamp
3-49	Pin	3-38	Metal plate washer
3-50	Pinion shaft	3-94	Cap nut
3-51	Ball bearing 6201	3-95	Regulating screw
3-52	O-ring 12x1.8	3-96	Adjusting pan
3-53	Bush	3-97	Washer
3-54	Gasket, upper case	3-98	Nut
3-55	Upper case	3-99	Piston
3-56	Clutch drum	3-100	Gear box body

**USER MANUAL-4 STROKE PETROL ENGINE**

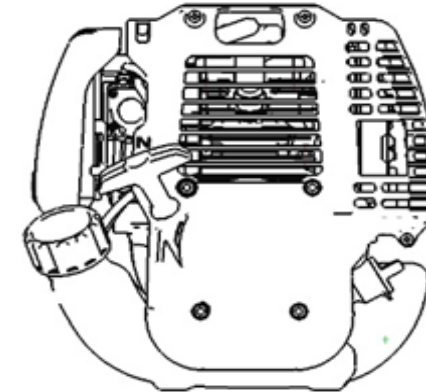

**BEFORE GETTING STARTED**

Please read this manual thoroughly before operating this gasoline engine. The manufacturer reserves the right to modify this manual without notice. The manufacturer shall assume no liability for incorrect information contained in this manual. Copying of any contents of this manual are forbidden without written approval. Some important information in this manual will be indicated in the following way. The users should pay special attention to these instructions.

**⚠ Danger** This indicates a hazardous situation, which, if not avoided, will result in death or serious injury.

**⚠ Warning** This indicates a hazardous situation, which, if not avoided, could result in death or serious injury.

**⚠ Caution** This indicates a hazardous situation, which, if not avoided, could result in minor or moderate injury.

**GENERAL DESCRIPTION**

The normal operation of the engine can be guaranteed under the natural environment of 268~313K. This type of gasoline engine can be used as the power source for the gasoline engine driven water pump, gardening equipment, lawn mower and other general machinery. This instruction manual is not applicable to gasoline engines for special purposes such as gasoline engine for motorcycle and outboard engine.

This general gasoline engine series are of excellent quality. They can be started up easily and reliably with strong power output, remarkable oil-saving effect, low operating noise and

**This warranty is null & void, if you fail to register the warranty with KisanKraft by sending the KisanKraft Copy with dealer's stamp.**

🌐: [www.kisankraft.com](http://www.kisankraft.com)    ✉: [info@kisankraft.com](mailto:info@kisankraft.com)    ☎: +91.80. 6835 7800

**This warranty is null & void, if you fail to register the warranty with KisanKraft by sending the KisanKraft Copy with dealer's stamp.**

🌐: [www.kisankraft.com](http://www.kisankraft.com)    ✉: [info@kisankraft.com](mailto:info@kisankraft.com)    ☎: +91.80. 6835 7800