



Agricultural Portable Sprayer (Power)
KK-P767/ P768/ P769/ P780, KK-TPS-60T
Agricultural Knapsack Sprayer (Power)
KK-707/ 708/X/AL, KK-KPS-162 / 802

Incidental / Consequential Loss: KisanKraft Limited or its manufacturers will not be liable for general damages, including bodily injuries, or for incidental or consequential damages including, but not limited to, loss of use, loss of profits, loss of production, expense of substitute equipment or other commercial loss or damage.

Limitation of Liability: This limited warranty is in lieu of all other express warranties, obligations, or liabilities. Any implied warranties, obligations or liabilities, including, but not limited to, any implied warranty of merchantability shall be limited in duration to the applicable warranty period. Any action for breach of any warranties hereunder, including, but not limited to, any implied warranty of merchantability must be brought within the applicable warranty period.

Modifications of Warranty: No agent, representative, dealer, or employee of KisanKraft Limited or any of its manufacturers has the authority to increase or alter the obligations of this warranty.

Assignment / Transfer of warranty: The warranty cannot be assigned and shall not transfer if the product is resold by the first buyer. The above warranties are extended to the first end user (original purchaser), and no warranty is made, nor authorized to be made assignable on resale by the first end user.

What you must do to obtain limited warranty service: To obtain performance of any obligation under this warranty for failure during the applicable warranty period, you must deliver the defective product, to the nearest Authorized Dealer, along with proof-of-purchase (invoice/receipt). KisanKraft Limited, its manufacturers and its dealers reserve the right to inspect the claimed defective part(s) to determine if the malfunction is the result of a defect covered by this warranty. Please note that the decision of KisanKraft Limited with respect to any warranty claim is final.

After-sales Service (Including Warranty): KisanKraft Limited does not sell directly to consumers. All sales or supplies are made through Authorized Dealers. It is the responsibility of the Authorized Dealer to provide all after-sales service to consumers. Any warranty claim should be raised by dealer to KisanKraft Limited as per warranty policy.

Jurisdiction: All disputes are subject to Bangalore court's jurisdiction.

Notes:

- This purchase is not contingent upon a product demonstration. The purchaser shall satisfy himself with the product, including any product demonstration or verification of any function, before buying. KisanKraft Limited or its authorized dealers, including online sellers, shall not be liable to give any on-site demonstration after purchase of any of the product.
- Any product once used will not be taken back by KisanKraft Limited.
- Warranty and After Sale Services (including but not limited to installation, Demonstration, Repair, Routine Maintenance etc.), should be done through the Authorized Dealer selling this product.
- Dealers should have their own technician to provide After Sales Services to their Customers. KisanKraft Limited provides free training to Authorized Dealer's technicians at KisanKraft Limited's head office, on request from Authorized Dealer.

This warranty is null & void, if you fail to register the warranty with KisanKraft by sending the KisanKraft Copy with dealer's stamp.



Warranty Certificate
 (DEALER COPY)

Product	Agricultural Knapsack Sprayer (Power) / Agricultural Portable Sprayer (Power) (2-Stroke)	KisanKraft Invoice Date	
Brand	KisanKraft	KisanKraft Invoice No.	
Model	<input type="checkbox"/> KK-708, <input type="checkbox"/> KK-708(AL-1), <input type="checkbox"/> KK-708X, <input type="checkbox"/> KK-707, <input type="checkbox"/> KK-P767, <input type="checkbox"/> KK-P-768, <input type="checkbox"/> KK-PPS-P769, <input type="checkbox"/> KK-P780 <input type="checkbox"/> KK-KPS-802, <input type="checkbox"/> KK-KPS-162, <input type="checkbox"/> KK <input type="checkbox"/> KK-TPS-60T		
WARRANTY PERIOD	6-MONTHS	FOR THE SPECIFIED PERIOD FROM THE DATE OF SALE OR DELIVERY WHICHEVER IS EARLIER.	
Dealer's Invoice Date		Dealer's Invoice No.	
Buyer's Info (Name, Address, Phone, etc.):		Dealer's Stamp (Address, Phone, TIN, etc.):	
Buyer's Sign		Dealer's Sign	

Warranty Policy

What is covered: KisanKraft Limited and its manufacturers warrant this product to be free from defects in material or workmanship. All parts defective in material and workmanship are covered.

This warranty will only cover defects arising under normal usage.

This warranty is limited to repair or replacement by KisanKraft Limited or its manufacturers of such parts as appear to KisanKraft or its manufacturers, upon inspection, to be defective in material and/or workmanship. KisanKraft or its manufacturers make no warranty with respect to items not manufactured or sold by them. No onsite warranty is provided by KisanKraft Limited or its manufacturers. Defective items must be brought/sent to our Authorized Dealer or KisanKraft Limited's office for service.

What is not covered: The *warranty shall become null and void* and neither KisanKraft Limited nor any of its manufacturers, nor its authorized dealers assumes any responsibility, if the failure was caused by the following:

- (1) Operation of product with incorrect fuel or lubricants, (2) Incorrect usage of machine or misuse, (3) Lack of maintenance, (4) Negligence, (5) Accident or physical damage, (6) Repairs made by unauthorized parties and/or with unauthorized parts, (7) Improper set up, adjustments, tampering or altered products (8) Any modification to the product what-so-ever.

Important: (1) Normal maintenance and adjustments to the product is the responsibility of the customer. (2) Normal wear and tear are not covered under warranty. (3) Rubber/plastic parts and consumables such as blades, clutch and clutch-bell, sparkplugs, nylon line, air-filters, fuel-filters, oil seals and gaskets etc. are not covered under the warranty. (4) Electrical Motor, Electrical Parts, Battery Etc. are not covered under the warranty.

This warranty is null & void, if you fail to register the warranty with KisanKraft by sending the KisanKraft Copy with dealer's stamp.



Warranty Certificate

(DEALER COPY)

Incidental / Consequential Loss: KisanKraft Limited or its manufacturers will not be liable for general damages, including bodily injuries, or for incidental or consequential damages including, but not limited to, loss of use, loss of profits, loss of production, expense of substitute equipment or other commercial loss or damage.

Limitation of Liability: This limited warranty is in lieu of all other express warranties, obligations, or liabilities. Any implied warranties, obligations or liabilities, including, but not limited to, any implied warranty of merchantability shall be limited in duration to the applicable warranty period. Any action for breach of any warranties hereunder, including, but not limited to, any implied warranty of merchantability must be brought within the applicable warranty period.

Modifications of Warranty: No agent, representative, dealer, or employee of KisanKraft Limited or any of its manufacturers has the authority to increase or alter the obligations of this warranty.

Assignment / Transfer of warranty: The warranty cannot be assigned and shall not transfer if the product is resold by the first buyer. The above warranties are extended to the first end user (original purchaser), and no warranty is made, nor authorized to be made assignable on resale by the first end user.

What you must do to obtain limited warranty service: To obtain performance of any obligation under this warranty for failure during the applicable warranty period, you must deliver the defective product, to the nearest Authorized Dealer, along with proof-of-purchase (invoice/receipt). KisanKraft Limited, its manufacturers and its dealers reserve the right to inspect the claimed defective part(s) to determine if the malfunction is the result of a defect covered by this warranty. Please note that the decision of KisanKraft Limited with respect to any warranty claim is final.

After-sales Service (Including Warranty): KisanKraft Limited does not sell directly to consumers. All sales or supplies are made through Authorized Dealers. It is the responsibility of the Authorized Dealer to provide all after-sales service to consumers. Any warranty claim should be raised by dealer to KisanKraft Limited as per warranty policy.

Jurisdiction: All disputes are subject to Bangalore court's jurisdiction.

Notes:

- This purchase is not contingent upon a product demonstration. The purchaser shall satisfy himself with the product, including any product demonstration or verification of any function, before buying. KisanKraft Limited or its authorized dealers, including online sellers, shall not be liable to give any on-site demonstration after purchase of any of the product.
- Any product once used will not be taken back by KisanKraft Limited.
- Warranty and After Sale Services (including but not limited to installation, Demonstration, Repair, Routine Maintenance etc.), should be done through the Authorized Dealer selling this product.
- Dealers should have their own technician to provide After Sales Services to their Customers. KisanKraft Limited provides free training to Authorized Dealer's technicians at KisanKraft Limited's head office, on request from Authorized Dealer.

This warranty is null & void, if you fail to register the warranty with KisanKraft by sending the KisanKraft Copy with dealer's stamp.



Warranty Certificate

(KISANKRAFT COPY)

Product	Agricultural Knapsack Sprayer (Power) / Agricultural Portable Sprayer (Power) (2-Stroke)	KisanKraft Invoice Date	
Brand	KisanKraft	KisanKraft Invoice No.	
Model	<input type="checkbox"/> KK-708, <input type="checkbox"/> KK-708(AL-1), <input type="checkbox"/> KK-708X <input type="checkbox"/> KK-707, <input type="checkbox"/> KK-P767, <input type="checkbox"/> KK-P-768, <input type="checkbox"/> KK-PPS-P769, <input type="checkbox"/> KK-P780 <input type="checkbox"/> KK-KPS-802, <input type="checkbox"/> KK-KPS-162, <input type="checkbox"/> KK-TPS-60T		
WARRANTY PERIOD	6-Months	FOR THE SPECIFIED PERIOD FROM THE DATE OF SALE OR DELIVERY WHICHEVER IS EARLIER.	
Dealer's Invoice Date		Dealer's Invoice No.	
Buyer's Info (Name, Address, Phone, etc.):		Dealer's Stamp (Address, Phone, TIN, etc.):	
Buyer's Sign		Dealer's Sign	

Warranty Policy

What is covered: KisanKraft Limited and its manufacturers warrant this product to be free from defects in material or workmanship. All parts defective in material and workmanship are covered.

This warranty will only cover defects arising under normal usage.

This warranty is limited to repair or replacement by KisanKraft Limited or its manufacturers of such parts as appear to KisanKraft or its manufacturers, upon inspection, to be defective in material and/or workmanship. KisanKraft or its manufacturers make no warranty with respect to items not manufactured or sold by them. No onsite warranty is provided by KisanKraft Limited or its manufacturers. Defective items must be brought/sent to our Authorized Dealer or KisanKraft Limited's office for service.

What is not covered: The warranty shall become null and void and neither KisanKraft Limited nor any of its manufacturers, nor its authorized dealers assumes any responsibility, if the failure was caused by the following:

- (1) Operation of product with incorrect fuel or lubricants, (2) Incorrect usage of machine or misuse, (3) Lack of maintenance, (4) Negligence, (5) Accident or physical damage, (6) Repairs made by unauthorized parties and/or with unauthorized parts, (7) Improper set up, adjustments, tampering or altered products (8) Any modification to the product what-so-ever.

Important: (1) Normal maintenance and adjustments to the product is the responsibility of the customer. (2) Normal wear and tear are not covered under warranty. (3) Rubber/plastic parts and consumables such as blades, clutch and clutch-bell, sparkplugs, nylon line, air-filters, fuel-filters, oil seals and gaskets etc. are not covered under the warranty. (4) Electrical Motor, Electrical Parts, Battery Etc. are not covered under the warranty.

This warranty is null & void, if you fail to register the warranty with KisanKraft by sending the KisanKraft Copy with dealer's stamp.

Wide Range of Products for Every Need



User Manual



KisanKraft Limited

Sri Huchhanna Tower, #4, 1st Main, 7-A Cross, Maruthi Layout, Dasarahalli,
 HAF Post, Hebbal, Bangalore 560024, Karnataka, INDIA

- ◆ Bangalore (HO) ◆ Ahmedabad ◆ Bhopal ◆ Bhubaneswar ◆ Coimbatore
- ◆ Guwahati ◆ Hubli ◆ Hyderabad ◆ Nellore ◆ Jaipur ◆ Karnal
- ◆ Kolkata ◆ Lucknow ◆ Pune ◆ Raipur

For more information give **MISSED CALL: 07676065555**



Many of our products have BIS: ISI certification.



This warranty is null & void, if you fail to register the warranty with
 KisanKraft by sending the KisanKraft Copy with dealer's stamp.



Scan the QR code to download
 KisanKraft App

App is available on



Scan the QR code for
 KisanKraft Youtube Channel



CONTENTS

BEFORE GETTING STARTED.....	7
SAFETY INSTRUCTIONS	7
OVERVIEW OF COMPONENTS.....	8
ASSEMBLY.....	9
OPERATING INSTRUCTIONS.....	10
MAINTENANCE AND STORAGE	16
TECHNICAL SPECIFICATIONS	18
TROUBLESHOOTING	19
DIAGRAM-POWER SPRAYER	21
PARTS LIST - POWER SPRAYER	22
PRESSURE PUMP PARTS - DIAGRAM.....	24
PRESSURE PUMP PARTS-LIST	25
2 STROKE PETROL ENGINE- USER MANUAL.....	27
PETROL ENGINE (2-STROKE)-PARTS DIAGRAM	41
PETROL ENGINE (2-STROKE)-PARTS LIST.....	42

KisanKraft has a large range of products to serve the farmers. A list of our products is given below:

<p>Brush Cutters and Accessories</p> <ul style="list-style-type: none"> Brush Cutter/Power Weeder Backpack Brush Cutter Tea Pruner Pole pruner with Engine Reaper Attachment Blades-Circular Blades (2 & 3 points) Baffle Nylon Rope Tap & Go <p>Chainsaws</p> <ul style="list-style-type: none"> Petrol Chainsaw Electric Chainsaw Chain Sharpening Machine <p>Engines and Water Pumps</p> <ul style="list-style-type: none"> Engine –Diesel-(Horizontal) Engine –Diesel-(Vertical) Engine-Kerosene Water Pump with Petrol Engine Water Pump with Kerosene Engine Water Pump with Diesel Engine <p>Hand Tools</p> <ul style="list-style-type: none"> Secateurs Folding Saw Garden Rake Garden Shovel Hedge Shear Lopper Telescopic Hedge Shear Telescopic Lopping Shear Tree Pruner Telescopic Steel Pipe & Fruit Picker Bag Sheep Shear <p>Garden Tools</p> <ul style="list-style-type: none"> Electric Pressure Washer Hedge Trimmer Lawn Mower (Electric, Petrol & Manual) Leaf Blower 	<p>Cultivators and Accessories</p> <ul style="list-style-type: none"> Petrol and Diesel <p>Sprayers and Accessories</p> <ul style="list-style-type: none"> Battery Sprayer Portable Power Sprayer Trolley Sprayer Manual Knapsack Sprayer Manual Pressure Sprayer Rose Cans Hose Crimping Machine HTP Sprayer HTP Delivery Hose HTP Hose Reel HTP Stand HTP Gun / Lance(Brass Rod) Knapsack Power Sprayer Mister / Duster / Granuel Spreader HTP Sprayer Set with Diesel Engine HTP Sprayer Set with Kerosene Engine Fogging Machine <p>Milking Machine</p> <ul style="list-style-type: none"> Wood Shredder Fodder Ensiling Chaff Cutter Fodder Grinder Chaff Cutter Fodder Mini Chaff Cutter <p>Harvester</p> <ul style="list-style-type: none"> Maize Sheller Maize Sheller + Dehusker Maize Combine Harvester Onion Digger Carlotti Italy Tea Leaf Harvester Sugarcane Combine Harvester Sugarcane Leaf Stripper <p>Transplanter and Post Hole Digger</p> <ul style="list-style-type: none"> Paddy Transplanter (2 & 8 Rows) Transplanter-Vegetable & Tobacco Post Hole Digger(4" to 14" Augers)
---	--

This warranty is null & void, if you fail to register the warranty with KisanKraft by sending the KisanKraft Copy with dealer's stamp.



Agricultural Portable Sprayer (Power)
 KK-P767/ P768/ P769/ P780, KK-TPS-60T
 Agricultural Knapsack Sprayer (Power)
 KK-707/ 708/X/AL, KK-KPS-162 / 802

Part No	Part Name	Part No	Part Name
E2-33	Spark Plug	E2-72	Fuel Pipe Long 708
E2-34	Gasket-Insulator	E2-72	Fuel Pipe Long 768
E2-35	Insulator	E2-73	Fuel Pipe Short 708
E2-36	Screw M5x20-Star	E2-73	Fuel Pipe Short 768
E2-37	Gasket -Carburetor	E2-74	N/A
E2-38	Carburetor	E2-75	Petrol Filter
E2-39	Air Cleaner Inside Cover	E2-76	Screw M5x16-Star
E2-40	N/A	E2-77	Starter Assy
E2-41	Screw M5x50-Allen	E2-78	E- Ring

This warranty is null & void, if you fail to register the warranty with KisanKraft by sending the KisanKraft Copy with dealer's stamp.



Warranty Certificate

(CUSTOMER COPY)

Product	Agricultural Knapsack Sprayer (Power) / Agricultural Portable Sprayer (Power) (2-Stroke)	KisanKraft Invoice Date	
Brand	KisanKraft	KisanKraft Invoice No.	
Model	<input type="checkbox"/> KK-708, <input type="checkbox"/> KK-708(AL-1), <input type="checkbox"/> KK-708X <input type="checkbox"/> KK-707, <input type="checkbox"/> KK-P767, <input type="checkbox"/> KK-P-768, <input type="checkbox"/> KK-PPS-P769, <input type="checkbox"/> KK-P780 <input type="checkbox"/> KK-KPS-802, <input type="checkbox"/> KK-KPS-162, <input type="checkbox"/> KK-TPS-60T		
WARRANTY PERIOD	6-MONTHS	FOR THE SPECIFIED PERIOD FROM THE DATE OF SALE OR DELIVERY WHICHEVER IS EARLIER.	
Dealer's Invoice Date		Dealer's Invoice No.	
Buyer's Info (Name, Address, Phone, etc.):		Dealer's Stamp (Address, Phone, TIN, etc.):	
Buyer's Sign		Dealer's Sign	

Warranty Policy

What is covered: KisanKraft Limited and its manufacturers warrant this product to be free from defects in material or workmanship. All parts defective in material and workmanship are covered. This warranty will only cover defects arising under normal usage. This warranty is limited to repair or replacement by KisanKraft Limited or its manufacturers of such parts as appear to KisanKraft or its manufacturers, upon inspection, to be defective in material and/or workmanship. KisanKraft or its manufacturers make no warranty with respect to items not manufactured or sold by them. No onsite warranty is provided by KisanKraft Limited or its manufacturers. Defective items must be brought/sent to our Authorized Dealer or KisanKraft Limited's office for service.

What is not covered: The *warranty shall become null and void* and neither KisanKraft Limited nor any of its manufacturers, nor its authorized dealers assumes any responsibility, if the failure was caused by the following: (1) Operation of product with incorrect fuel or lubricants, (2) Incorrect usage of machine or misuse, (3) Lack of maintenance, (4) Negligence, (5) Accident or physical damage, (6) Repairs made by unauthorized parties and/or with unauthorized parts, (7) Improper set up, adjustments, tampering or altered products (8) Any modification to the product what-so-ever.

Important: (1) Normal maintenance and adjustments to the product is the responsibility of the customer. (2) Normal wear and tear are not covered under warranty. (3) Rubber/plastic parts and consumables such as blades, clutch and clutch-bell, sparkplugs, nylon line, air-filters, fuel-filters, oil seals and gaskets etc. are not covered under the warranty. (4) Electrical Motor, Electrical Parts, Battery Etc. are not covered under the warranty.

Incidental / Consequential Loss: KisanKraft Limited or its manufacturers will not be liable for general damages, including bodily injuries, or for incidental or consequential damages including, but not limited to, loss of use, loss of profits, loss of production, expense of substitute equipment or other commercial loss or damage.

Limitation of Liability: This limited warranty is in lieu of all other express warranties, obligations, or liabilities. Any implied warranties, obligations or liabilities, including, but not limited to, any implied warranty of merchantability shall be limited in duration to the applicable warranty period. Any action for breach of any warranties hereunder, including, but not limited to, any implied warranty of merchantability must be brought within the applicable warranty period.

Modifications of Warranty: No agent, representative, dealer, or employee of KisanKraft Limited or any of its manufacturers has the authority to increase or alter the obligations of this warranty.

Assignment / Transfer of warranty: The warranty cannot be assigned and shall not transfer if the product is resold by the first buyer. The above warranties are extended to the first end user (original purchaser), and no warranty is made, nor authorized to be made assignable on resale by the first end user.

What you must do to obtain limited warranty service: To obtain performance of any obligation under this warranty for failure during the applicable warranty period, you must deliver the defective product, to the nearest Authorized Dealer, along with proof-of-purchase (invoice/receipt). KisanKraft Limited, its manufacturers and its dealers reserve the right to inspect the claimed defective part(s) to determine if the malfunction is the result of a defect covered by this warranty. Please note that the decision of KisanKraft Limited with respect to any warranty claim is final.

After-sales Service (Including Warranty): KisanKraft Limited does not sell directly to consumers. All sales or supplies are made through Authorized Dealers. It is the responsibility of the Authorized Dealer to provide all after-sales service to consumers. Any warranty claim should be raised by dealer to KisanKraft Limited as per warranty policy.

Jurisdiction: All disputes are subject to Bangalore court's jurisdiction.

Notes:

- This purchase is not contingent upon a product demonstration. The purchaser shall satisfy himself with the product, including any product demonstration or verification of any function, before buying. KisanKraft Limited or its authorized dealers, including online sellers, shall not be liable to give any on-site demonstration after purchase of any of the product.
- Any product once used will not be taken back by KisanKraft Limited.
- Warranty and After Sale Services (including but not limited to installation, Demonstration, Repair, Routine Maintenance etc.), should be done through the Authorized Dealer selling this product.
- Dealers should have their own technician to provide After Sales Services to their Customers. KisanKraft Limited provides free training to Authorized Dealer's technicians at KisanKraft Limited's head office, on request from Authorized Dealer.

This warranty is null & void, if you fail to register the warranty with KisanKraft by sending the KisanKraft Copy with dealer's stamp.

Part No	Part Name	Part No	Part Name
E2-15	Screw M5x45-Allen	E2-58	Rope Reel
E2-16	Guide Cover Assy	E2-58/1	Ratchet Spring
E2-17	Screw M5x16-Star	E2-58/2	Ratchet Starter
E2-18	N/A	E2-59	Recoil Spring
E2-19	Crank Shaft Assy	E2-60	Screw -Ratchet
E2-20	Piston	E2-61	N/A
E2-21	Piston Pin	E2-62	Starter Rope
E2-22	Piston Rings	E2-63	Starter Handle
E2-23	Circlip-Piston Pin	E2-64	Start Reel
E2-24	Needle Bearing-Piston Pin	E2-65	Start Claw
E2-25	Key-Crank Shaft	E2-66	Claw Spring
E2-26	Nut M8-Flanged Hex	E2-67	N/A
E2-27	Fly Wheel	E2-68	Fuel Tank 708
E2-28	Ignition Coil	E2-68	Fuel Tank 768/800
E2-29	Cap-Spark Plug	E2-69	Fuel Tank Lid 708
E2-30	Grommet -Cord Comp	E2-69	Fuel Tank Lid 768/800
E2-31	Cord Comp-Coil	E2-70	Gasket-Fuel Tank Lid
E2-32	Screw M5x20-Star	E2-71	Fuel Pipe Grommet

PETROL ENGINE (2-STROKE)-PARTS LIST

Part No	Part Name	Part No	Part Name
E2-1	Crankcase Big	E2-42	Air Filter Sponge
E2-1A	Crank Case Small	E2-43	Air Cleaner Outside Cover
E2-1B	Fan Cover	E2-44	Screw -Air Filter
E2-2	Screw M5X25-Allen	E2-45	N/A
E2-3	Screw M5X20-Star	E2-46	N/A
E2-4	Stop Ring 28-Inner	E2-47	Gasket-Muffler
E2-5	Gasket-Crankcase	E2-48	Muffler
E2-6	Bearing-6001	E2-49	N/A
E2-7	Oil Seal-Big 12x30x7	E2-50	N/A
E2-8	Oil Seal-Small 12x22x7	E2-51	Clutch Shoe Assy
E2-9	N/A	E2-52	N/A
E2-10	N/A	E2-53	Spring-Clutch
E2-11	N/A	E2-54	Clutch Bolt
E2-12	Cylinder	E2-55	Washer B-Clutch
E2-13	Gasket -Cylinder	E2-56	Washer A-Clutch
E2-14	Screw M5x16-Allen	E2-57	Starter Cover

This warranty is null & void, if you fail to register the warranty with KisanKraft by sending the KisanKraft Copy with dealer's stamp.

BEFORE GETTING STARTED

Please read and follow the instructions in this manual before using the machine. The user should be familiar with the safety notices, machine performance, and maintenance, etc. The operation manual will be used later in case of any repair, accessories replacement, and accessories procurement, so preserve it carefully.

SAFETY INSTRUCTIONS

- Using this machine with extra high pressure is prohibited ($\leq 35\text{kgf/cm}^2$) ;
- The rotating parts should have a safety protective device;
- Protective Clothing;

- Wear flange cap.
- Wear dirt/fog-proof glasses.
- Wear gauze mask.
- Wear long gloves.
- Wear coat guarding against poisons.
- Wear boots.

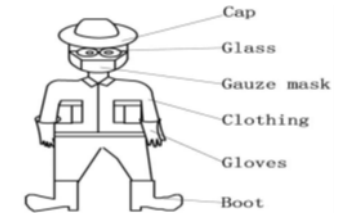

- Spraying towards personnel and working at the downwind position are prohibited;
- Running the machine without water or lubricating oil is prohibited;
- Using special working solutions as strong acid, strong alkali, etc. is prohibited
- Following personnel should not use the machine:
 - Mentally challenged.
 - Drunk.
 - Under the age of 18 or older people.
 - Person with no knowledge of the machine.
 - Tired person or patient and others who cannot operate the machine normally.
 - A person who has just exercised strenuously or has not slept enough. Women feeding breast milk to the baby or is pregnant.
- Spraying
 - It is fine to carry out an operation during cool weather with little wind. For example, early in the mornings or in the late afternoons as this can reduce the evaporation and drift of chemicals and improve the protective effect.
 - The operator should move windward.
 - If your mouth or eyes are spattered with chemicals, wash them with clean water and then visit a doctor.
 - If the operator has a headache or dizziness, should stop working at once and consult a doctor immediately.
 - For the operator's safety, misting/dusting must be carried out strictly according to the instruction of the chemicals and agricultural requirements.

- Spray over, according to pesticide manual to clean out any residual spray mixture in chemical tank.
- After spraying always wash your hands and face thoroughly

OVERVIEW OF COMPONENTS

KK-707/708 / KK-708-(AL1) /KK-KPS-802/162:

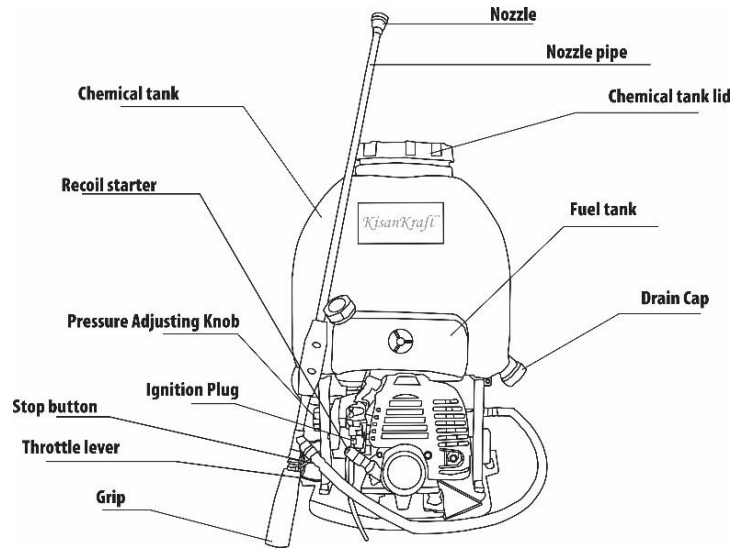

PETROL ENGINE (2-STROKE)-PARTS DIAGRAM

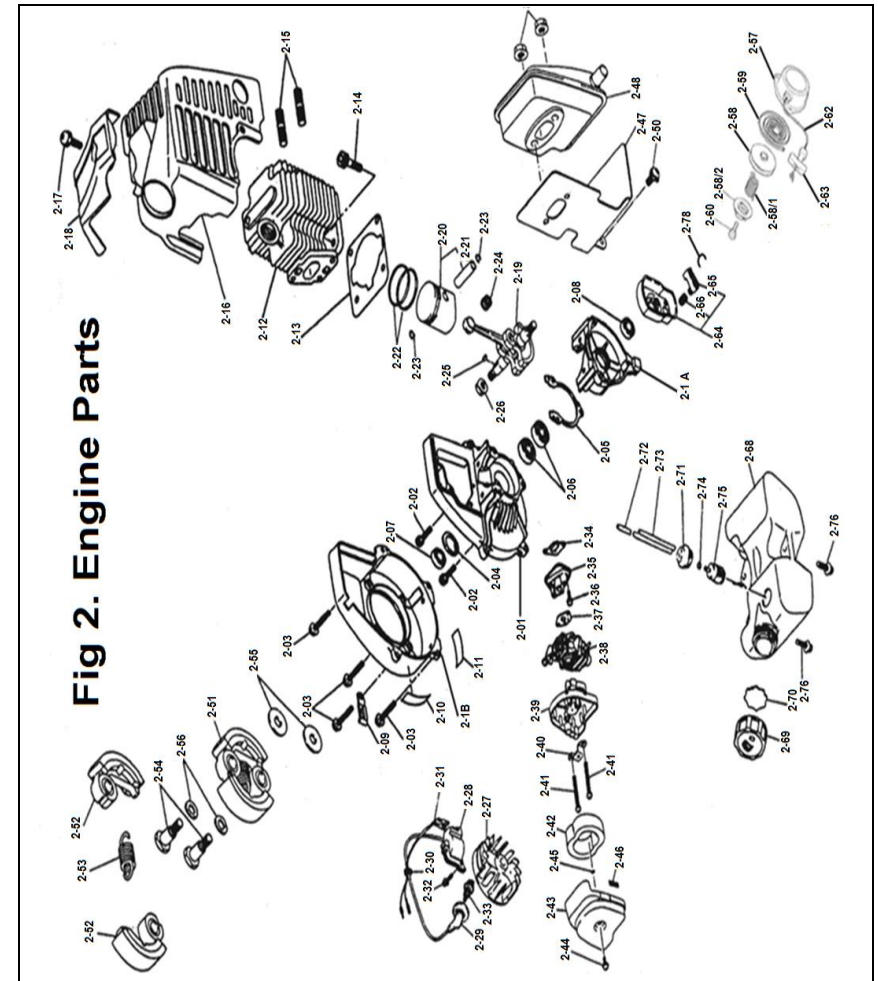

This warranty is null & void, if you fail to register the warranty with KisanKraft by sending the KisanKraft Copy with dealer's stamp.

STORAGE

When releasing the engine from operation for more than 30 days, it must be serviced and stored as follows with care to prevent the starting trouble or malfunction due to degeneration of fuel.

1. Drain the fuel from the fuel tank and start to run the engine till it is stopped due to use-up of fuel.
2. Wash the inside of fuel tank and fuel filter with white kerosene.
 - ⚠ Use of fire is strictly prohibited
3. Removing the ignition plug, inject a small quantity of new engine oil through the plughole. After idling slowly for few revolutions operating the recoil starter, install the ignition plug. Pull the recoil starter again and stop it at the position where it is felt heavy.
4. Clean the external surfaces with soft cloth and store it at a dry place free from fires.

NOTE: If the unit is left over without draining fuel, impurities in the fuel could clog the fuel passages such as the carburetor, fuel filter, or others, and cause engine troubles. Make sure to drain the fuel when storing the unit for a long period of time.

⚠ Sufficient care must be taken not to use fires at the vicinity when handling the fuel.

KK-P767/ P-768 / P769 / P780 & KK-TPS- 60T:

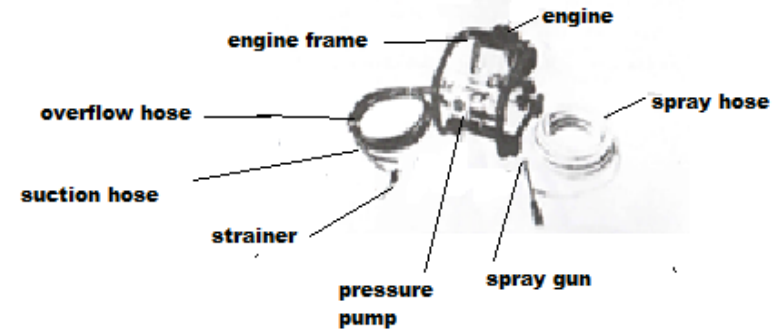

ASSEMBLY

KK-707/ 708 / KK-708-(AL1) /KK-KPS-802/162:

Attach the wide nozzle, the nozzle pipe, the ball cock in an order to the spray hose, and connect the other end of the hose to the spray outlet.

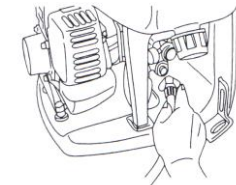

This warranty is null & void, if you fail to register the warranty with KisanKraft by sending the KisanKraft Copy with dealer's stamp.

OPERATING INSTRUCTIONS

Pre-Operation Preparation:

Oiling

1. Make sure to use 2T exclusive oil.
2. Make sure that the engine is stopped and cooled.
3. Neither overfill nor spill the fuel on the engine

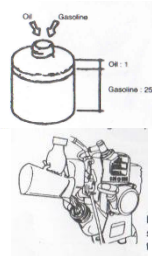

Dilution of chemicals/Charging the chemical tank

(Applicable for KK-707/ 708 / KK-708-(AL1) /KK-KPS-802/162)

Caution: Agricultural chemicals are extremely dangerous, and must be handled with utmost care. Read the manual for the specific chemical carefully before use.

Dissolve water dispersible powder in a separate container before filling, be sure not to get foreign material into chemicals.

Always fill the chemical tank through the strainer so that contaminants are not mixed into the chemicals.

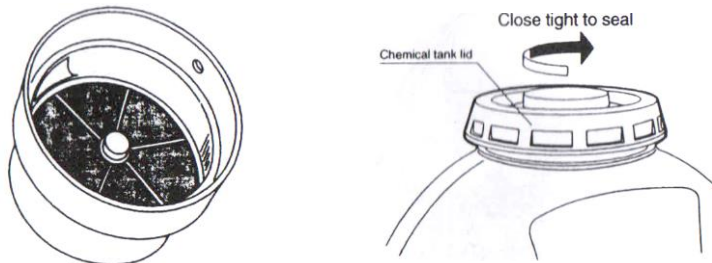

Open the air bleed nozzle, and bleed until the chemical is draining out, and then close the nozzle securely. Before spraying the agrochemical, be sure to put on suitable protective clothing to protect yourself against contact with and breathing it. Observe the following cautions for safe operation:

- a) Be sure to close the chemical tank cover securely.

This warranty is null & void, if you fail to register the warranty with KisanKraft by sending the KisanKraft Copy with dealer's stamp.

INSPECTION AND SERVICE BEFORE EACH OPERATION

Cleaning of air cleaner

Wash the element with white kerosene and then immerse it in engine oil. Squeeze it tightly with single hand.

! Use of fire is strictly prohibited

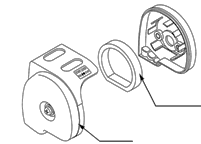

Cleaning and service at respective sections

- Clean thoroughly around the muffler.
- Clean the cooling fins and the cooling air inlet.
- Inspect and retighten bolts and nuts.
- Inspect the fuel leakage.

INSPECTION AND SERVICE AT EVERY 50-HOUR

Cleaning and adjustment of ignition plug

After removing carbon accumulated on the electrodes and the insulator, adjust the clearance between the electrodes at 0.6 ~ 0.7 mm

! When mounting the plug cap, push it in securely

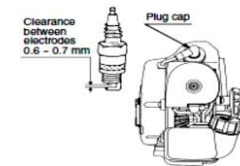

Cleaning of fuel filter

Using a piece of wire, or the likes, pull out the fuel filter and wash with clean white kerosene. When it is fouled heavily, replace the filter and also wash the tank inside.

! Use of fire is strictly prohibited

Carbon removal

Remove carbon from the muffler in-/outlet, cylinder and piston. This work requires engine servicing skill and some tools. Consult the dealer or nearest service center.

! CAUTIONS DURING INSPECTION

- Disconnect the ignition plug wires before inspection or adjustment to prevent unexpected start of engine.
- Do not touch the engine immediately after operation to prevent burn.
- Use of fire is strictly prohibited when handling the fuel (gasoline).
- Make sure to clean spilled fuel sufficiently before using the engine.
- Do not wash the engine with water.
- Do not change the setting revolution speed carelessly. (Consult your dealer when changing the revolution speed.)

INSPECTION AND SERVICE

Table of regular inspections

Item \ Time	Before Each Operation	At Every 50-hours	At Every 100-hours	2 Years
Inspection and retightening of bolts, nuts	✓			
Inspection of fuel leakage	✓			
Inspection, cleaning of air cleaner	✓			
Cleaning at cooling air inlet, cooling fin and around muffler	✓			
Inspection, cleaning of ignition plug		✓		
Inspection, cleaning of fuel filter		✓		
Removal of carbon from muffler, cylinder		✓		
Cleaning of spark arrestor		✓		
Replacement of ignition plug			✓	
Replacement of fuel piping (fuel pipe and grommet)				✓

- b) Check the spray hose and nozzle connections to make sure there are no leakage.
- c) Always stop the engine before refilling the fuel tank or changing the nozzle.
- d) When carrying a full chemical tank, be careful not to lose your balance.

Starting the Engine (Applicable for all the models):

Important: When starting the engine, be sure to fill the chemical tank with pure water or chemical liquid. Never run the engine when the chemical tank is empty.

1. Pump the primer bulb until fuel can be seen flowing through the fuel return line, and pull the choke lever to full close. (During hot weather and when the engine is already warmed up, the choke lever may be set to either half open or full open).
2. Set the throttle lever to the middle speed position (not necessarily to maximum).

KK-707/ 708 / KK-708-(AL1) /KK-KPS-802/162:

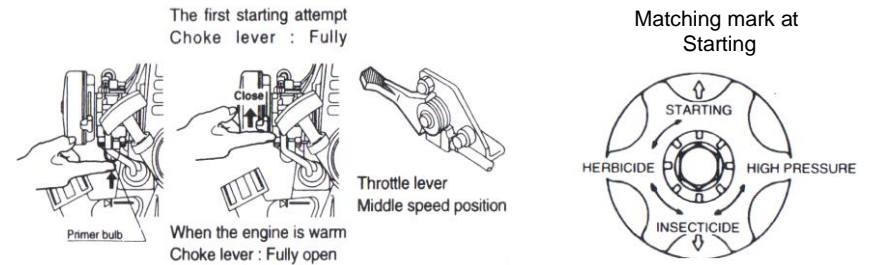

This warranty is null & void, if you fail to register the warranty with KisanKraft by sending the KisanKraft Copy with dealer's stamp.

KK-P767/ P-768 / P769 / P780 & KK-TPS- 60T:

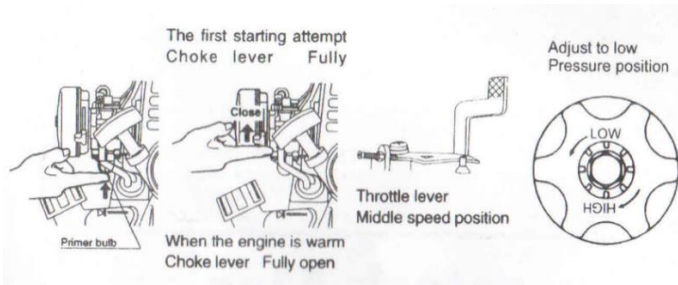

3. Pull the recoil starter lightly 2-3 times.
4. Pull the recoil starter strongly to start the engine.
5. If the engine stops after a few revolutions, set the choke to half open, and pull the recoil starter rope strongly again to restart it.

Note: If the engine does not catch even after the starter is pulled several times, set the choke lever to full open and pull the starter rope. Be sure not to pull the starter lever completely out. After the engine starts, open the choke lever slowly, move the throttle lever to the low –speed side, and let the sprayer warm up for 2-3 minutes.

Pull briskly:

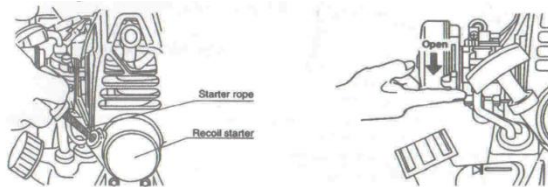

ADJUSTING THE CARBURETOR

! Engine revolution speed is adjusted at the optimum condition before shipping from the factory. It should be adjusted only when it fails to operate properly. (Consult your dealer when adjustment is necessary.)

1. Use the slow speed adjusting screw to adjust the slow speed revolutions.
 - Right turns: Increase the revolution speed.
 - Left turns: Slow down the revolution speed.

! Increasing the slow revolution excessively causes the driven equipment unable to stop even if the throttle lever is returned. The revolution speed should not be increased excessively.

2. In case with the slow speed fuel adjusting screw Normal position is where it is returned by one turn from the fully closed position (right turn).
 - Right turns: Increase the thickness of fuel.
 - Left turns: Decrease the thickness of fuel.
3. In case with the high speed fuel adjustment screw
 - Right turns: Decrease the thickness of fuel.
 - Left turns: Increase the thickness of fuel.

! Fuel adjustment for the carburetor is completed at the optimum condition before shipping from the factory. When it is necessary to adjust, consult your dealer.

! Do not decrease the thickness of fuel too much. (It could result in the seizure trouble of engine.)

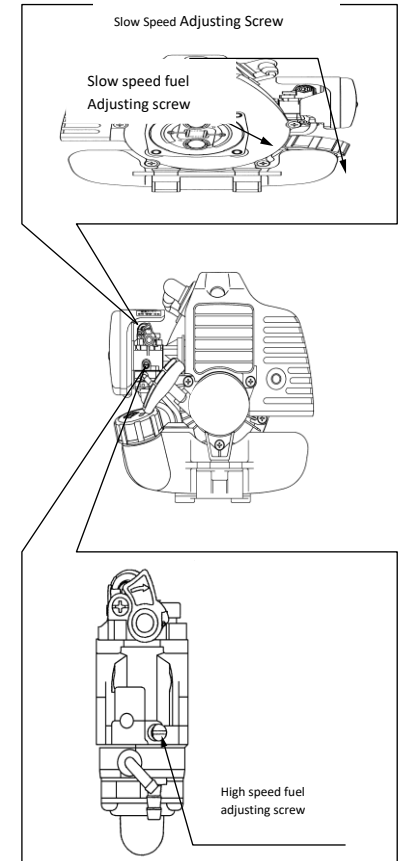

This warranty is null & void, if you fail to register the warranty with KisanKraft by sending the KisanKraft Copy with dealer's stamp.

PRECAUTIONS DURING OPERATION

- After starting the engine, set the throttle lever at the slow speed position and warm up the engine for approx. 2-3 minute. As the engine warms up, the engine will be accelerated smoothly.
- Do not attempt to raise the engine speed abruptly immediately after the start because the lubrication oil may not be distributed at all over the engine.
- If the throttle lever is turned to the fully opened position, the revolution speed picks up to a considerably higher level, which could not only shorten the life of engine but also cause trouble. It should be avoided to race the engine at high speed under no load condition or raise the speed unnecessarily.
- Before starting operation, make sure to inspect the engine in accordance with the "Inspection before starting the engine".
- Do not operate the engine at the indoor or a place with poor ventilation. (Exhaust gas contains odorless and harmful carbon monoxide.)
- Do not insert in or approach hands or foot at the moving or rotating sections.
- Stop the engine immediately if it has been discovered any leakage of fuel or gas from the carburetor, muffler, fuel tank, crankcase, cylinder or mating face at respective sections. (Contact a dealer or service center for repair.)
- Do not change the setting revolution speed of engine unnecessarily.
- Be careful not to touch highly heated muffler or sections on the engine to avoid possible risk of burn.
- Do not operate the engine while withered grasses, leaves or other inflammable substances are sticking in or around the muffler cover.
- Do not touch the ignition plug cap or high-voltage cord during operation. (There is risk of electric shock or physical injury.)
- Do not operate the engine with the muffler or air cleaner cover removed

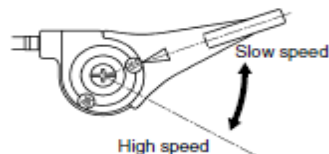

Operation (KK-707/ 708 / KK-708-(AL1) /KK-KPS-802/162)

1. Turn the handle of the control valve, and set it to the position for HERBICIDE, INSECTICIDE or HIGH PRESSURE to match the pressure of the operating conditions.

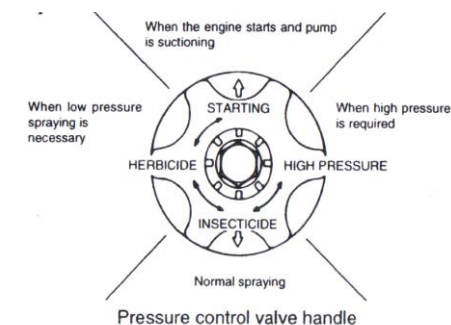

2. Check the spraying conditions and the status of the equipment, then shoulder the equipment and set the throttle lever to the high speed position.

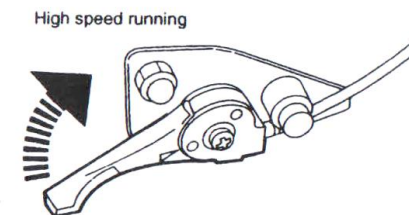

3. When the nozzle cock is opened, chemicals will be atomized as they come out of the nozzle.

IMPORTANT

1. When the pressure control valve is changed to INSECTICIDE or HERBICIDE, with the throttle being fully open at HIGH PRESSURE position of pressure control valve handle, the engine speed will become too high, corresponding to the extent of lowered pressure. Therefore, use the equipment with the throttle lever somewhat turned back from the fully opened condition, when the equipment is used at the position for INSECTICIDE or HERBICIDE.
2. Be careful of the amount of fuel in the tank, and refill it when it becomes low.

This warranty is null & void, if you fail to register the warranty with KisanKraft by sending the KisanKraft Copy with dealer's stamp.

To Stop:

Temporary halt during operation:

1. Close the spray gun, and return the throttle lever to low speed.
2. Press the engine stop button.
3. After the engine stops, set the sprayer down and close the fuel cock.

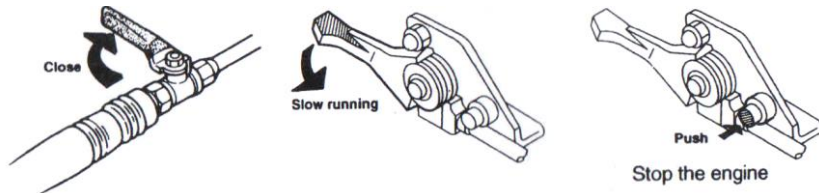

Stopping the sprayer after completing spraying:

1. Remove the chemical tank drain cap, drain off all of the chemical
2. Fill the chemical tank with clean water, operate the engine, and clean the pump and hose interior by spraying the clean water. Drain off the remaining water through the drain.

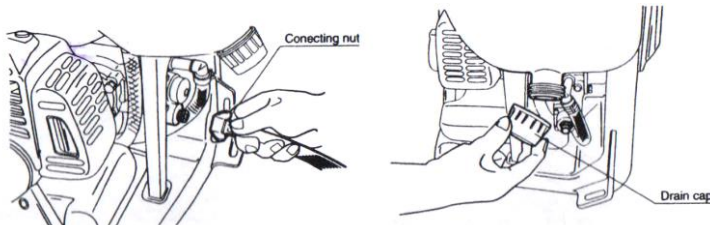

Start the engine at just less than high speed for 15-20 seconds to spray out the water in the spray hose and nozzle. When water stops coming from the nozzle, turn off the engine at once.

1. Set the throttle lever at the slow speed position.

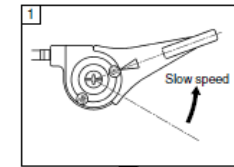

2. Turn the engine switch to the "OFF" position. (Switch position may vary depending on the specifications. Refer to the instruction manual of driven equipment.)

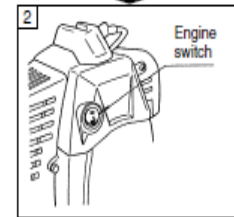

In case of a push button type switch, keep pressing the push button till the engine stops completely.

- Replenish the fuel before using up completely. It will make easier at the next starting.
- When there is no subsequent work, drain the fuel from the fuel tank and restart the engine to use up the fuel remaining in the carburetor.

CAUTION

- Place the engine at a horizontal position when the driven equipment is not used at the rest time, or others, in summer season. (If the tank is tilted as much as the inside of fuel cap is submerged in the fuel, the fuel may leak.)
- Do not touch the engine body, especially the muffler, during or immediately after stopping the operation. (There is risk of burn.)

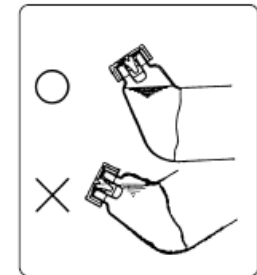

This warranty is null & void, if you fail to register the warranty with KisanKraft by sending the KisanKraft Copy with dealer's stamp.

- While holding down the engine firmly, grasp the recoil starter grip and pull vigorously

⚠ CAUTION:

- When the engine stops on the way after starting, or
- When the engine fails to start after trying the recoil operation for 7 to 8 times.

Return the starter lever to the operating position and try the recoil operation.

- If you move the throttle lever to the high-speed side a little after the engine has started, the starter lever returns to the operating position. Continue the warm-up operation for 2 to 3 minutes in this condition. Observing the condition of the engine, move the throttle lever to a desired engine speed.

START

⚠ CAUTION

- Before starting the engine, confirm that the area of radius 15 m around the engine is completely evacuated.
- Do not operate the engine when any flammable material (gasoline, volatile chemicals, or others) is present around it.
- Driven equipment may start simultaneously with the start of engine. Carefully read the instruction manual of the equipment and start the engine carefully.
- When a class FC oil is used, a larger resistance may be felt when pulling the recoil starter grip under low temperature condition or at the initial operation at the next season. This is related to the characteristic of the oil and there is no problem on the engine. Once started, it will return to the normal condition

Concerning New Start System

It can start even if it is pulled slower than normal.

- If the rope is pulled (vigorously) till it will not come out any more, it could damage the recoil mechanism.
- Do not disassemble the recoil. It is dangerous to disassemble the inside of recoil. (Consult your dealer when it is necessary to replace related parts.)
- If the decompression slot of cylinder is clogged, the engine may start slower than normal. Clean the slot to restore the normal condition.

STOP

This warranty is null & void, if you fail to register the warranty with KisanKraft by sending the KisanKraft Copy with dealer's stamp.

Operation (KK-P767/ P-768 / P769 / P780 & KK-TPS- 60T):

- Turn the handle of the control valve to match the pressure of operating conditions.
- Check spraying conditions and the status of the equipment, and set the throttle lever to the high speed position.
- When the nozzle cock is opened, chemicals will be atomized as they come out of the nozzle.

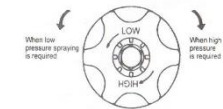

Pressure control valve handle

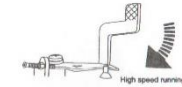

IMPORTANT

- After each 4 continuous working hours, please turn the cap of grease cup for 1 or 2 rounds. This will lubricate the piston and prolong its life.
- After every 100 working hours, please inspect the engine oil level in the pressure pump (you can see it from the oil window of the pump). In case, the oil level is lower than 1/3 position, please remove the oil inlet bolt and add engine oil up to 2/3 position
- Be careful of the amount of fuel in the tank, and refill it when it becomes low.

To Stop:

Temporary halt during operation:

- Close the spray gun, and return the throttle lever to low speed.
- Press the engine stop button.
- After the engine stops, close the fuel cock.

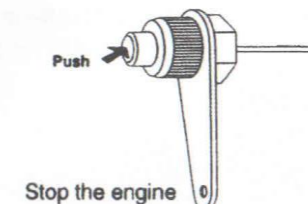

Stopping the sprayer after completing spraying:

- Drain off all of the chemical from the chemical tank.
- Fill the chemical tank with clean water, operate the engine, and clean the pump and hose interior by spraying the clean water.

Start the engine at just less than high speed for 15-20 seconds to spray out the water in the spray hose and nozzle. When water stops coming from the nozzle, turn off the engine at once.

MAINTENANCE AND STORAGE

Cleaning the air cleaner:

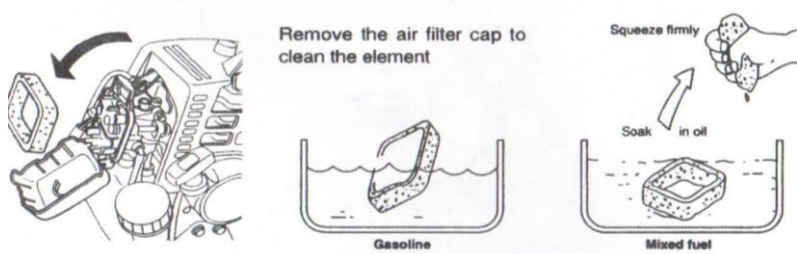

Plug:

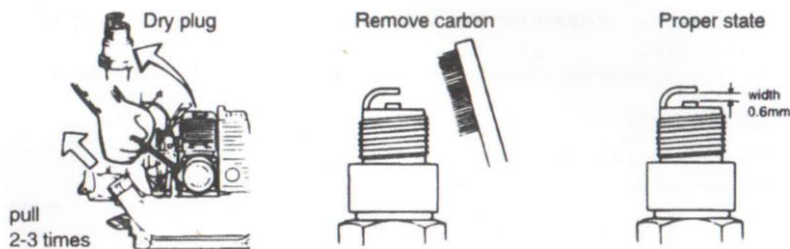

This warranty is null & void, if you fail to register the warranty with KisanKraft by sending the KisanKraft Copy with dealer's stamp.

- When the engine has started, return the choke lever gradually to the fully opened position (at the  Mark).
 If only exploding sounds are heard, but it does not start, return the choke lever to the fully closed position and pull the starter grip vigorously once again.

START (STARTER LEVER TYPE UNIT)

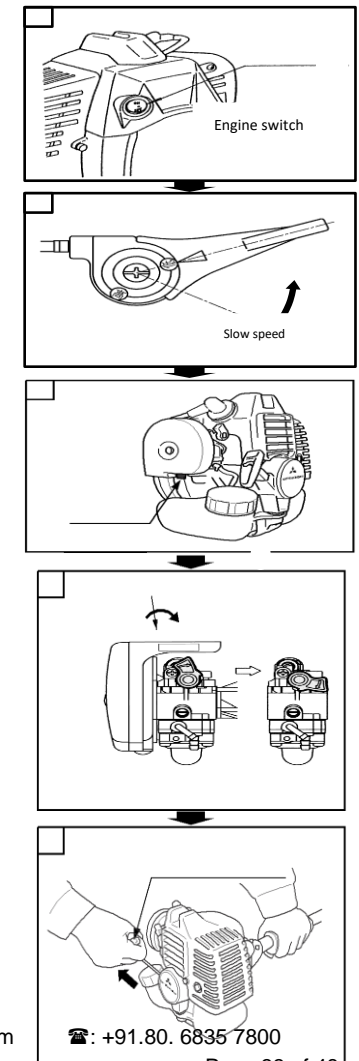

- Turn the engine switch to the "ON" side.
- Set the throttle lever at the slowest speed position.
- Push the priming button repeatedly with finger till it hits the top. (More than 10 times)
 Pressing the priming button is necessary to prime the fuel to facilitate the start-up. Since any excess amount of primed fuel returns to the tank, there is no problem of over-priming. Prime the fuel rather more than sufficiently to avoid starting trouble.
- Turn down the starter lever of carburetor to set it at the start position.
 It is not necessary to operate the starter lever when the engine is warmed up (For about 15 minutes after stopping the engine.)
 (To be left in the operating position)
 Depending on specifications, the starter lever may be provided at the throttle wire side.



OPERATION INSTRUCTIONS

Methods of starting & stopping the engine

START (CHOKE TYPE UNIT):

1. Turn the engine switch to the "ON" side.
2. Set the throttle lever at the slow speed position.
3. Push the priming button repeatedly with finger till it hits the top. (More than 10 times) Pressing the priming button is necessary to prime the fuel to facilitate the start-up. Since any excess amount of primed fuel returns to the tank, there is no problem of over-priming. Prime the fuel rather more than sufficiently to avoid starting trouble.
4. Turn the choke lever to the fully closed position (at the  Mark).
 When sufficient fuel is retained and the engine is warm, set the choke lever at the fully opened position (at the  mark)
5. While holding down the engine firmly, grasp the recoil starter grip and pull vigorously

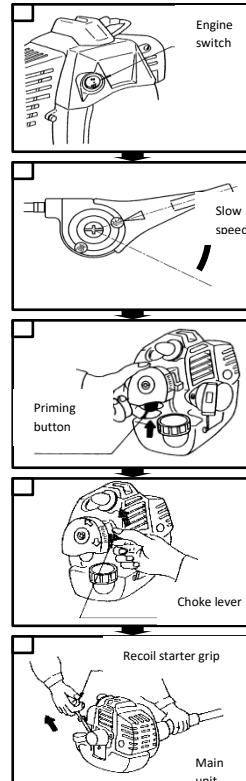

Storage:

After using the sprayer for the season, store it until the next season of use as follows:

1. Drain off all fuel from the fuel tank and the carburetor.
2. Remove the spark plug and coat the cylinder with a small amount of oil. Pull the recoil starter lightly 2-3 times to spread the oil over the cylinder completely as shown in the figure below.

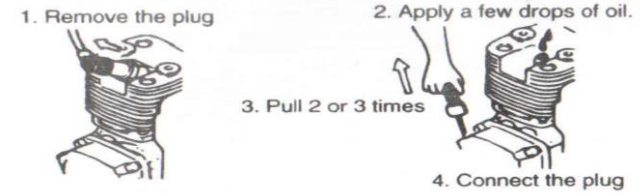

3. Pull the recoil starter out slightly and stop it in place where you feel the pull start (compression starts).
4. Clean the entire sprayer completely, cover it so it does not accumulate dirt and dust, and store it in a dry, cool location.

This warranty is null & void, if you fail to register the warranty with KisanKraft by sending the KisanKraft Copy with dealer's stamp.

TECHNICAL SPECIFICATIONS

Model	KK-708-AL1	KK-708X	KK-707/708	KK-KPS-162	KK-KPS-802	KK-TPS-60T	KK-P767/P-768	KK-PPS-P769	KK-P780
Rated Power	0.7kW (1hp)	0.75 kW (1 hp)	0.7 kW (0.94 hp)	0.7kW (1hp)					
Displacement	26 cc	34 cc	25.6 cc			26 CC		34 cc	43cc
Engine Type	2 - stroke								
RPM	7500		6500	7500		7000	7500		
Fuel Used	Petrol								
Fuel Tank Capacity	750 ml	600 ml	750 ml	600 ml		600 ml / 750 ml	600 ml	1 L	
Chemical tank capacity	20 L			25 L	60 L	N/A			
Oil (Mixing)	40ml (2T) oil per 1 Liter of Petrol & 100 ml (20W 40 Grade) for Gear Box								
Fuel Consumption / Out Put Capacity	500-600 ml/hour (Engine) & 420 Liter/hour (Output)			7.49 L/min	500-600 ml/hour (Engine) & 420 Liter/hour (Output)				
Weight	11 kg	9 kg	8.75 kg	10 kg	(With hose) 70 kg	10.2 kg	10 kg		
Feature	Knapsack			Trolley			Portable		
Suction Volume	7-8 L/min			7.49 L/min	8 L/min	9 L/min			

INSPECTION OF RESPECTIVE SECTIONS:

Make sure to inspect these sections before operating the engine.

Inspection of fuel

- Is sufficient quantity of oil reserved?
- Is not the fuel degenerated?
- Use the proper fuel referring to the "Fuel" section.

CAUTION

- Sufficient care must be taken on the fire not only when replenishing but also handling fuel. It could cause fire or explosion.
- Securely close the oil tank cap. Fuel may leak if the cap is tightened aslant. It will never leak if the cap is tightened properly. (Excluding: TL tank cap breather type)

Inspection of clogging

- Check the cooling fins, around the muffler and cooling air inlet for trash or withered grasses trapped.
- Remove them if necessary

Inspection of air cleaner

- Is not fouled the air cleaner element?
- When the element is fouled or it is not impregnated with oil, inspect and service it in accordance with "Inspection and servicing before each operation"

Inspection of screws and nuts

- Check respective sections for loose or missing screws or nuts.
- Service them if necessary.

Inspection of fuel pipes

- Check for cracks or fissures on the fuel pipe and grommet, disconnection or fuel leakage from joints on the fuel tank and carburetor.

CAUTION

Cracks, fissures or disconnection from joints could cause fire or explosion by leaked fuel. Service or replace damaged fuel pipe and grommet.

This warranty is null & void, if you fail to register the warranty with KisanKraft by sending the KisanKraft Copy with dealer's stamp.

INSPECTION BEFORE OPERATING THE ENGINE

NOTE: In 2 Stroke engine the gasoline and engine oil are mixed and poured together.
FUEL: Use mixed oil of ordinary regular gasoline for vehicle and special 2-cycle engine oil with the proportion as shown by the following table.
 Mixing ratio (Volumetric ratio):

Petrol: 2-cycle engine oil
40: 1

- Do not use degenerated oil (with sour smell).
- (It could cause engine trouble such as the starting error, insufficient output, etc.)
- Make sure to clean spilled fuel. It could foul clothes or cause fire.
- Do not use 4-cycle engine oil. (It could cause fouled plug, bound piston ring, clogged muffler, or other problem.)
- Take care while handling gasoline. (As there is a risk of explosion.)

ADJUSTMENT OF THROTTLE WIRE:

Adjust the play on the throttle wire to 0.5 ~ 1.0 mm.

LARGER PLAY

- It could cause the starting trouble.
- Revolution speed could rise unexpectedly when the external wire of throttle wire comes off from the position.

NO PLAY

- Driven equipment may fail to stop even if the throttle lever is returned.

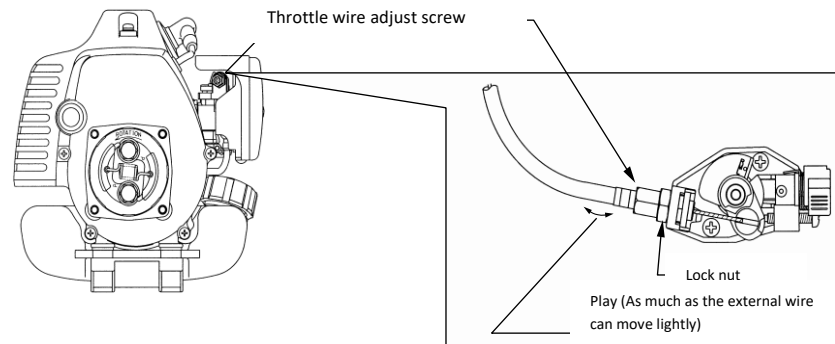

This warranty is null & void, if you fail to register the warranty with KisanKraft by sending the KisanKraft Copy with dealer's stamp.

TROUBLESHOOTING

Pump:

Trouble	Cause	Remedy
No Suction	Hose is Loose	Tighten the hose carefully
	Suction hose is clogged with chemicals.	Disassemble and clean the hose.
	Worn piston packing.	Replace with a new piston
	Foreign object in valve parts.	Disassemble and clean the valve.
Poor spray quality	Worn piston packing	Replace with a new piston
	Flaw in cylinder inner surface	Replace with a new cylinder
	Flaw in exhaust valve	Replace with a new valve
	Worn pressure control valve handle	Replace with a new handle
	Foreign object in valve parts	Disassemble and clean the valve.
	Worn nozzle hole.	Replace with a new nozzle.
	Too many nozzle attached	Reduce number of nozzles or replace with nozzle of smaller holes.

When engine fails to start:

Trouble	Cause	Remedy		
There is fuel, but spark plugs fail to ignite.	There is power at the terminal.	Drawing too much fuel Faulty spark plug gap. Faulty spark plug insulation.	Tuning the carburetor Adjust the spark plug gap Replace the spark plug	
	No power at the terminal	Faulty TCI unit or broken wire A break or short in the ignition coil.	Replace the ignition coil.	
	There is fuel and spark plug ignites	Compression is good	Bad Mixture	Adjust the carburetor
		Compression is bad	Faulty packing	Tighten the spark plug
Spark plugs not tightened properly Piston rings are sticking			Tighten the spark plug Replace the piston ring	
No fuel in the carburetor	No fuel in the tank	Fill the tank with fuel		
	Fuel valve is faulty or fuel tank air vent is clogged.	Clear air vent hole		
	Lines are bent	Replace lines		

Engine fails to run smooth:

Trouble		Cause	Remedy
No power	Compression is good and there is no misfire	Air cleaner element is plugged up.	Clean or replace air cleaner if necessary
		Air has entered fuel line joints.	Clear the fuel line
		Faulty choke lever	Replace choke lever
		Carbon build up on cylinder muffler.	Clean the muffler
	Compression is bad	Burnt spark plugs	Replace the spark plug
		Short in cable	Replace the cable
Engine overheated	Bad mixture or piston ring wear.	Replace the piston ring	
	Marks on cylinder. Cracks in the piston head	Replace the piston	
	Fuel is too low (mixture is too thin).	Engine over oiling.	
	Faulty mixture, not enough mixture.	Clear the lines	
	Carbon piled up, overloaded operation.	Clean the carbon	
Inaccurate explosion	Faulty spark plugs.	Replace the spark plugs	
	Plugged cylinder or coolant lines	Clean the coolant lines	
	Carburetor not adjusted properly.	Adjust the carburetor gap properly	
Engine doesn't sound right	Faulty spark plugs.	Replace the spark plug	
	Faulty magneto or internal short	Replace he magnet	
	Overheated cylinders	Replace the cylinder	
	Overload operation	Right quantities of petrol and oil should be mixed to enable proper lubrication	
Slow acceleration	Faulty mixture or incorrect ratio	Replace the necessary spares/contact service person	
	Internal engine damage	Replace the necessary spares/contact service person	
	Carburetor not adjusted properly or faulty compression	Adjust the carburetor gap properly	
Slow acceleration	Poor gasoline oil quality	Use good quality gasoline-oil mixture.	
	Carbon pile up	Clean the carbon	

COMPONENTS OVERVIEW

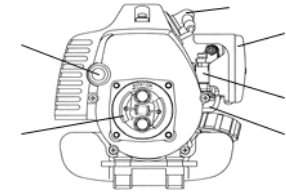
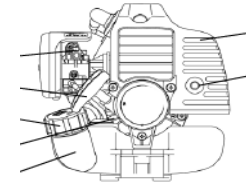

1. Recoil starter grip	8. Engine switch (Types vary depending on the specifications.)
2. Starter lever	9. Clutch
3. Cooling air inlet	10. Ignition plug cap
4. Fuel tank cap	11. Air cleaner
5. Fuel tank	12. Carburetor
6. Muffler	13. Priming button
7. Exhaust outlet (Types vary depending on the specifications.)	

This warranty is null & void, if you fail to register the warranty with KisanKraft by sending the KisanKraft Copy with dealer's stamp.

- Do not operate the engine when grass, leaves or inflammable substances are sticking in or around the muffler.
- Do not touch parts of muffler or engine at high temperatures. (There is risk of burns.)
- Do not touch the ignition plug or high-voltage cord during operation. (There is risk of electric shock or physical injury.)
- Make sure to stop the engine whenever the work is interrupted or moving the engine to another place.
- Do not operate the engine alone. (It must be connected to the driven equipment when it is operated).
- Check frequently the parts used on the fuel line for cracks or leakage, and replace them if necessary.
- Remove dirt, grass or other trash from the cooling fins and the cooling air inlet. (Make sure to stop the engine and the driven equipment before the cleaning.)
- Make sure to use always new gasoline. (Old gasoline may cause sticky substance adhering at the inside of carburetor causing trouble in operation.)
- Before starting the engine, confirm that the area of radius 15 m around it is evacuated and no tank filled with fuel, or others are not left over.
- Use only genuine parts supplied from the manufacturer. Use of parts other than the genuine parts could cause engine trouble or premature abrasion.

Note: Important safety items quoted in this manual do not necessarily cover all situations or conditions that could occur. Although sufficient care has been taken to assure the safety of the engine, operators or service personnel must observe necessary precautions to operate it safely and protect themselves from possible dangers.

DIAGRAM-POWER SPRAYER

(Knapsack Power Sprayers)

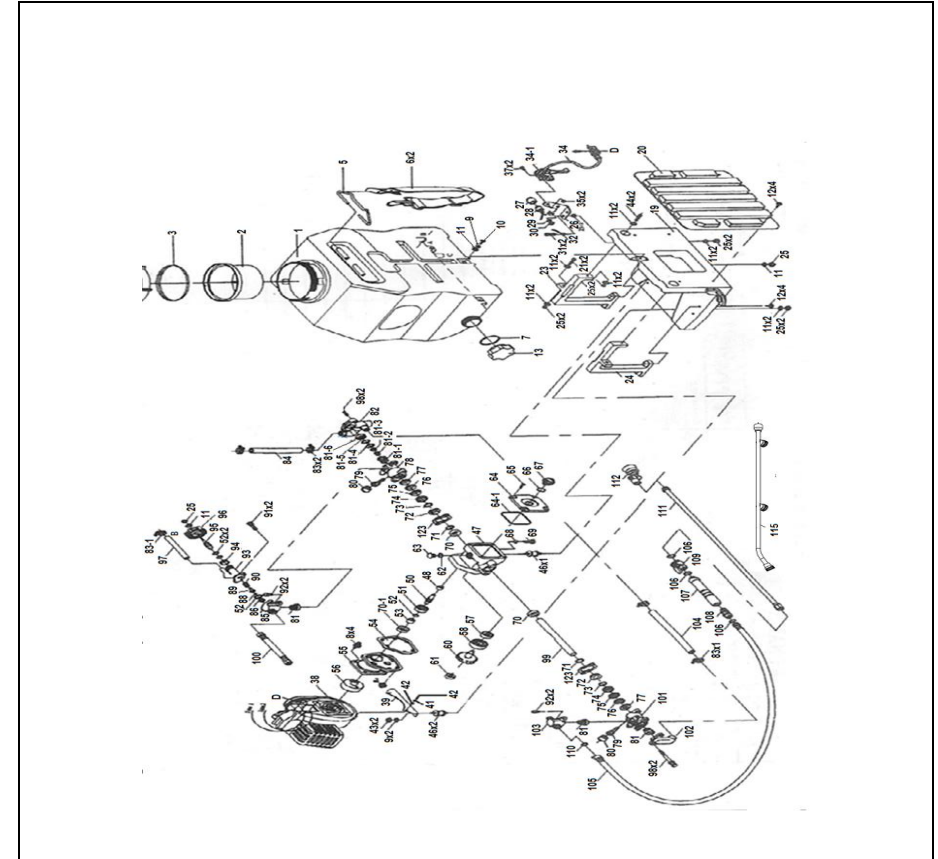

This warranty is null & void, if you fail to register the warranty with KisanKraft by sending the KisanKraft Copy with dealer's stamp.

PARTS LIST - POWER SPRAYER

Part no.	Part name (body)	Part no.	Part name (body)
B1	Chemical Tank 708	B56	Clutch Drum
B1	Chemical Tank 800	B57	Bearing-6200
B2	Strainer (Big)-Chemical Tank	B58	Bearing-6203
B3	Gasket-Chemical Tank Lid	B59	N/A
B4	Chemical Tank Lid	B60	Gear
B5	Belt Holder	B61	Bearing-608
B6	Shoulder Belt	B62	'O' Ring-Oil Inlet Bolt
B7	Gasket -Drain Cap	B63	Oil Inlet Bolt
B8	Screw M6x18-Hex	B64	Crank Case Cover
B9	Washer 6-Spring	B64-1	'O' Ring -Crank Case Cover
B10	S T Screw	B65	Screw -Crank Case Cover
B11	Washer 6-Plain	B66	'O' Ring -Oil Glass
B12	Screw M6x25-Star	B67	Oil Glass
B13	Drain Cap-Chemical Tank	B68	'O' Ring -Oil Drain Bolt
B19	Frame 708/800	B69	Oil Drain Bolt
B19	Frame-Metal 768	B70	Oil Seal -18x28x8
B20	Rubber Pad	B70-1	Oil Seal -18x28x8
B21	Screw M6x18-Hex	B71	'O' ring-Plunger
B23	Right Stand	B72	Adjusting Ring
B24	Left Stand	B73	Grease Seal
B25	Nut M6-Nylon	B74	Grease Ring
B26	Fixed Plate-Flex Accelerator	B75	V-Packing
B28	Switch On/Off	B76	N/A
B30	Nut M8-Hex	B77	V-Packing Seat
B31	Screw M6x18-Hex	B78	Cylinder-Right
B32	Cord Comp-Wire	B79+80	Grease Cup
B33	N/A	B81	Valve Assy
B34	Throttle Cable	B82	Suction Chamber-Right
B34-1	Flex Accelerator	B83	Clip-L
B35	Nut M6-Nylon	B83-1	Clip-S
B37	Screw M6x18-Hex	B84	Suction Hose-5" 708/800
B38	N/A	B84	Suction Hose-2.5Mts 768
B39	Engine Stand	B85	Outlet Chamber -Right

This warranty is null & void, if you fail to register the warranty with KisanKraft by sending the KisanKraft Copy with dealer's stamp.

2 STROKE PETROL ENGINE- USER MANUAL

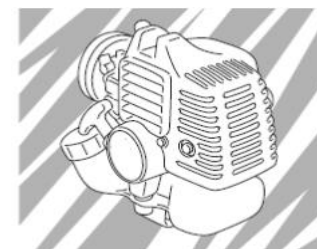

BEFORE GETTING STARTED

This manual describes various cautions necessary to operate the engine properly. Before starting the engine, read the manual and understand the proper method of use. (Improper use of the engine could result in accident or injury.)
 Use the engine after reading and understanding also the manual of equipment driven by the engine.
 Keep the manual at a safe place where you can refer whenever needed.

SAFETY INSTRUCTIONS

	You have to observe the descriptions indicated with this mark because they contain very important information to assure the safety
--	--

- No person who does not understand the content of this manual should be allowed to operate the engine.
- Engine should not be operated indoors or in places with poor ventilation. (Exhaust gas contains odorless and harmful carbon monoxide.)
- Do not insert in or approach hands or foot near the moving or revolving sections.
- Do not store, spill or use gasoline at the vicinity of fire, stove, furnace or devices using the pilot flame or sparks like water heater or others. (There is risk of explosion.)
- Do not refill the fuel indoors or at a place not well ventilated.
- Do not smoke while filling the fuel.
- Do not remove the fuel tank cap or refill the fuel while the engine is still running or immediately after operation when the engine is still hot. (Wait for more than 2 minutes after terminating the operation before refilling the fuel.)
- Do not operate the engine when gasoline has spilled, smell of gasoline is felt as there is a risk of explosion.
- Do not adjust the setting engine speed unnecessarily.
- Do not check sparks while the ignition plug is removed.
- Do not operate the engine with the muffler or air cleaner cover removed. (Inspect particularly the muffler at regular intervals for loose mounting screws, breakage or leakage, and repair or replace it if any abnormality is observed.)



Agricultural Portable Sprayer (Power)
 KK-P767/ P768/ P769/ P780, KK-TPS-60T
 Agricultural Knapsack Sprayer (Power)
 KK-707/ 708/X/AL, KK-KPS-162 / 802

Part no.	Part name (body)	Part no.	Part name (body)
3-55	Upper case	3-99	Piston
3-56	Clutch drum	3-100	Gear box body



Agricultural Portable Sprayer (Power)
 KK-P767/ P768/ P769/ P780, KK-TPS-60T
 Agricultural Knapsack Sprayer (Power)
 KK-707/ 708/X/AL, KK-KPS-162 / 802

Part no.	Part name (body)	Part no.	Part name (body)
B40	Washer 5-Plain	B86	Steel Ball Seat
B41	Washer 5-Spring	B88	Steel Ball
B42	Screw M5x25-Allen	B89	Pressure Valve Rod
B43	Nut M6-Nylon	B90	Relief Valve Spring
B46	Joint-S	B91	Screw M6x18-Hex
B46-1	Joint-L	B92	Screw M6x18-Hex
B47	Crank Case	B93	Relief valve Body
B48	Needle Bearing-For Shaft	B94	Brass Nut-Relief Valve
B50	Shaft	B95	Relief Valve Screw
B34	Throttle Cable	B96	Pressure Adjusting Knob
B34-1	Flex Accelerator	B97	Over Flow Hose-5" 708/800
B35	Nut M6-Nylon	B97	Over Flow Hose-2.5Mts 768
B37	Screw M6x18-Hex	B98	Screw M6x75-Hex
B38	N/A	B99	Plunger
B39	Engine Stand	B100	High Pressure Hose -Small
B40	Washer 5-Plain	B101	Cylinder-Left
B41	Washer 5-Spring	B102	Suction Chamber-Left
B42	Screw M5x25-Allen	B103	Outlet Chamber-Left
B43	Nut M6-Nylon	B104	Suction Hose-9"
B46	Joint-S	B105	High Pressure Hose -Big
B46-1	Joint-L	B106	Packing -Handle/Spray Rod
B47	Crank Case	B107	Hose Pipe Handle
B48	Needle Bearing-For Shaft	B108	N/A
B50	Shaft	B109	Ball Cock-One Way
B51	Bearing-6201	B110	Packing-High Pressure Hose
B52	'O' Ring-Steel Pipe	B111	Spray Rod
B53	Steel Pipe	B115	Nozzle(3 Hole)
B54	Gasket-Drum Case	B123	Fixed Plane
B55	Drum Case		

This warranty is null & void, if you fail to register the warranty with KisanKraft by sending the KisanKraft Copy with dealer's stamp.

PRESSURE PUMP PARTS - DIAGRAM

(Portable Power Sprayer)

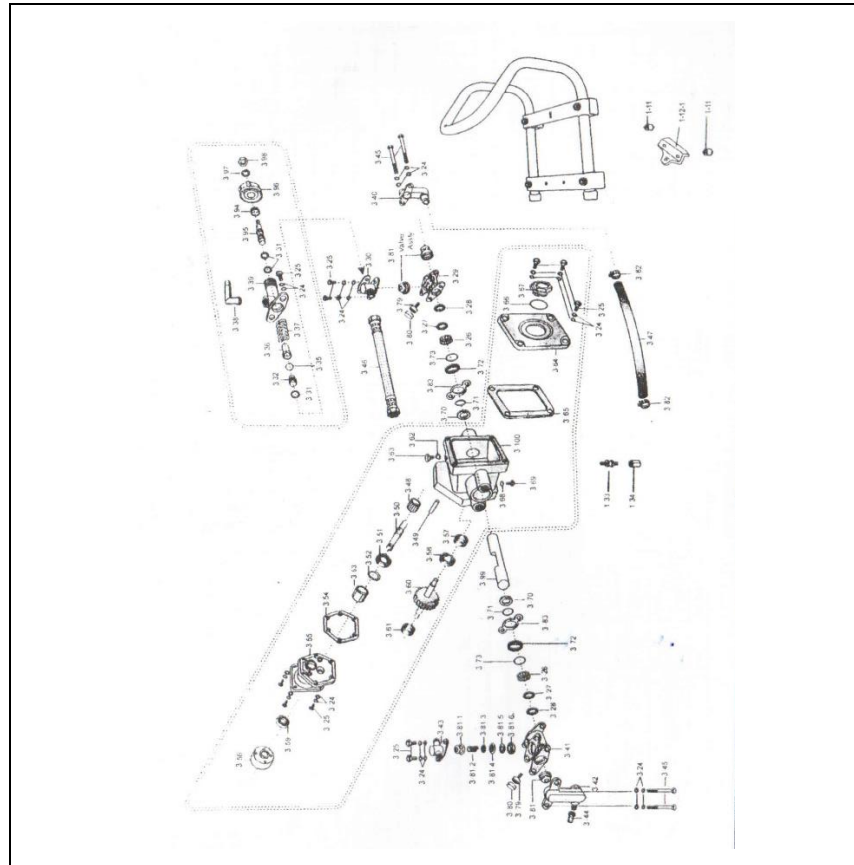

PRESSURE PUMP PARTS-LIST

Part no.	Part name (body)	Part no.	Part name (body)
1-11	Shake- proof plug 6 mm	3-57	Ball bearing 608
1-12-1	Fixing bracket	3-58	Ball bearing 6203
3-24	Washer	3-59	Oil seal for upper case
3-25	Hex bolt m6x16	3-60	Gear shaft
3-26	Grease ring	3-61	Ball bearing 608
3-27	V-packing	3-62	O-ring 12x1.8
3-28	Adjusting ring	3-63	Oil inlet bolt
3-29	Right pressure chamber	3-64	Gear box cover
3-30	Right delivery chamber	3-65	O-ring, gear box cover
3-31	O-ring 10x1.8	3-66	O-ring, oil window 31x 3
3-32	Valve seat	3-67	Oil window
1-33	Shake- proof plug 6 mm	3-68	O-ring 6.3x1.8
1-34	Pump bracket	3-69	Oil outlet bolt
3-35	Ball valve	3-70	Oil seal for piston
3-36	Spring seat	3-71	O-ring for piston 17x1.8
3-37	Spring	3-72	Packing seat
3-38	Overflow joint	3-73	O-ring 18x2.65
3-39	Pressure regulating valve body	3-79	Grease cup
3-40	Right suction chamber	3-80	Cap for grease cup
3-41	Left pressure chamber	3-81	Valve assembly
3-42	Left suction chamber	3-81-1	Valve cage
3-43	Left delivery chamber	3-81-2	Valve spring
3-44	Suction joint	3-81-3	Valve plug
3-45	Hex bolt m6x73	3-81-4	Valve seat
3-46	Pump delivery hose assembly	3-81-5	Valve ring
3-47	Pump suction hose	3-81-6	Valve packaging
3-48	Roller bearing	3-82	Hose clamp
3-49	Pin	3-38	Metal plate washer
3-50	Pinion shaft	3-94	Cap nut
3-51	Ball bearing 6201	3-95	Regulating screw
3-52	O-ring 12x1.8	3-96	Adjusting pan
3-53	Bush	3-97	Washer
3-54	Gasket, upper case	3-98	Nut

This warranty is null & void, if you fail to register the warranty with KisanKraft by sending the KisanKraft Copy with dealer's stamp.