

Product	Agricultural Inter-Cultivator	KisanKraft Invoice Date	
Brand	KisanKraft	KisanKraft Invoice No.	
Model	<input type="checkbox"/> KK-IC-208P <input type="checkbox"/> KK-IC-205P		
WARRANTY PERIOD	6 MONTHS	FOR THE SPECIFIED PERIOD FROM THE DATE OF SALE OR DELIVERY WHICHEVER IS EARLIER.	
Dealer's Invoice Date		Dealer's Invoice No.	
Buyer's Info (Name, Address, Phone, etc.):		Dealer's Stamp (Address, Phone, TIN, etc.):	
Buyer's Sign		Dealer's Sign	

Warranty Policy

What is covered: KisanKraft Limited and its manufacturers warrant this product to be free from defects in material or workmanship. All parts defective in material and workmanship are covered. This warranty will only cover defects arising under normal usage.

This warranty is limited to repair or replacement by KisanKraft Limited or its manufacturers of such parts as appear to KisanKraft or its manufacturers, upon inspection, to be defective in material and/or workmanship. KisanKraft or its manufacturers make no warranty with respect to items not manufactured or sold by them. No onsite warranty is provided by KisanKraft Limited or its manufacturers. Defective items must be brought/sent to our Authorized Dealer or KisanKraft Limited's office for service.

What is not covered: The *warranty shall become null and void* and neither KisanKraft Limited nor any of its manufacturers, nor its authorized dealers assume any responsibility, if the failure was caused by the following:

(1) Operation of product with incorrect fuel or lubricants, (2) Incorrect usage of machine or misuse, (3) Lack of maintenance, (4) Negligence, (5) Accident or physical damage, (6) Repairs made by unauthorized parties and/or with unauthorized parts, (7) Improper set up, adjustments, tampering or altered products (8) Any modification to the product what-so-ever.

Important: (1) Normal maintenance and adjustments to the product is the responsibility of the customer. (2) Normal wear and tear are not covered under warranty. (3) Rubber/plastic parts and consumables such as blades, clutch and clutch-bell, sparkplugs, nylon line, air-filters, fuel-filters, oil seals and gaskets etc. are not covered under the warranty. (4) Electrical Motor, Electrical Parts, Battery Etc. are not covered under the warranty.

Incidental / Consequential Loss: KisanKraft Limited or its manufacturers will not be liable for general damages, including bodily injuries, or for incidental or consequential damages including, but not limited to, loss of use, loss of profits, loss of production, expense of substitute equipment or other commercial loss or damage.

Limitation of Liability: This limited warranty is in lieu of all other express warranties, obligations, or liabilities. Any implied warranties, obligations, or liabilities, including, but not limited to, any implied warranty of merchantability shall be limited in duration to the applicable warranty period. Any action for breach of any warranties hereunder, including, but not limited to, any implied warranty of merchantability must be brought within the applicable warranty period.

Modifications of Warranty: No agent, representative, dealer, or employee of KisanKraft Limited or any of its manufacturers has the authority to increase or alter the obligations of this warranty.

Assignment / Transfer of warranty: The warranty cannot be assigned and shall not transfer if the product is resold by the first buyer. The above warranties are extended to the first end user (original purchaser), and no warranty is made, nor authorized to be made assignable on resale by the first end user.

What you must do to obtain limited warranty service: To obtain performance of any obligation under this warranty for failure during the applicable warranty period, you must deliver the defective product, to the nearest Authorized Dealer, along with proof-of-purchase (invoice/receipt). KisanKraft Limited, its manufacturers and its dealers reserve the right to inspect the claimed defective part(s) to determine if the malfunction is the result of a defect covered by this warranty. Please note that the decision of KisanKraft Limited with respect to any warranty claim is final.

After-sales Service (Including Warranty): KisanKraft Limited does not sell directly to consumers. All sales or supplies are made through Authorized Dealers. It is the responsibility of the Authorized Dealer to provide all after-sales service to consumers. Any warranty claim should be raised by dealer to KisanKraft Limited as per warranty policy.

Jurisdiction: All disputes are subject to Bangalore court's jurisdiction.

Notes:

- This purchase is not contingent upon a product demonstration. The purchaser shall satisfy himself with the product, including any product demonstration or verification of any function, before buying. KisanKraft Limited or its authorized dealers, including online sellers, shall not be liable to give any on-site demonstration after purchase of any of the product.
- Any product once used will not be taken back by KisanKraft Limited.
- Warranty and After Sale Services (including but not limited to installation, Demonstration, Repair, Routine Maintenance etc.), should be done through the Authorized Dealer selling this product.
- Dealers should have their own technician to provide After Sales Services to their Customers. KisanKraft Limited provides free training to Authorized Dealer's technicians at KisanKraft Limited's head office, on request from Authorized Dealer.

User Manual



KK-IC-208P



KK-IC-205P

KisanKraft Limited

Warehouse: 818 3B1 to 818 3B18, Podalukur - Sangam Road, Prabagiripatnam,
Podalukur, Nellore - 524345, Andhra Pradesh, INDIA

Head Office: Sri Huchhanna Tower, #4, 1st Main, 7-A Cross, Maruthi Layout,
Dasarahalli, HAF Post, Hebbal, Bangalore 560024, Karnataka, INDIA

- ◆ Bangalore (HO) ◆ Ahmedabad ◆ Bhopal ◆ Bhubaneswar ◆ Coimbatore
- ◆ Guwahati ◆ Hubli ◆ Hyderabad ◆ Jaipur ◆ Karnal
- ◆ Kolkata ◆ Lucknow ◆ Nellore ◆ Pune ◆ Raipur



Scan the QR code to download
KisanKraft App

App is available on



Scan the QR code for
KisanKraft Youtube Channel



Product	Agricultural Inter-Cultivator	KisanKraft Invoice Date	
Brand	KisanKraft	KisanKraft Invoice No.	
Model	<input type="checkbox"/> KK-IC-208P <input type="checkbox"/> KK-IC-205P		
WARRANTY PERIOD	6 MONTHS	FOR THE SPECIFIED PERIOD FROM THE DATE OF SALE OR DELIVERY WHICHEVER IS EARLIER.	
Dealer's Invoice Date		Dealer's Invoice No.	
Buyer's Info (Name, Address, Phone, etc.):		Dealer's Stamp (Address, Phone, TIN, etc.):	
Buyer's Sign		Dealer's Sign	

Warranty Policy

What is covered: KisanKraft Limited and its manufacturers warrant this product to be free from defects in material or workmanship. All parts defective in material and workmanship are covered. This warranty will only cover defects arising under normal usage.

This warranty is limited to repair or replacement by KisanKraft Limited or its manufacturers of such parts as appear to KisanKraft or its manufacturers, upon inspection, to be defective in material and/or workmanship. KisanKraft or its manufacturers make no warranty with respect to items not manufactured or sold by them. No onsite warranty is provided by KisanKraft Limited or its manufacturers. Defective items must be brought/sent to our Authorized Dealer or KisanKraft Limited's office for service.

What is not covered: The *warranty shall become null and void* and neither KisanKraft Limited nor any of its manufacturers, nor its authorized dealers assume any responsibility, if the failure was caused by the following:

- (1) Operation of product with incorrect fuel or lubricants, (2) Incorrect usage of machine or misuse, (3) Lack of maintenance, (4) Negligence, (5) Accident or physical damage, (6) Repairs made by unauthorized parties and/or with unauthorized parts, (7) Improper set up, adjustments, tampering or altered products (8) Any modification to the product what-so-ever.

Important: (1) Normal maintenance and adjustments to the product is the responsibility of the customer. (2) Normal wear and tear are not covered under warranty. (3) Rubber/plastic parts and consumables such as blades, clutch and clutch-bell, sparkplugs, nylon line, air-filters, fuel-filters, oil seals and gaskets etc. are not covered under the warranty. (4) Electrical Motor, Electrical Parts, Battery Etc. are not covered under the warranty.

Incidental / Consequential Loss: KisanKraft Limited or its manufacturers will not be liable for general damages, including bodily injuries, or for incidental or consequential damages including, but not limited to, loss of use, loss of profits, loss of production, expense of substitute equipment or other commercial loss or damage.

Limitation of Liability: This limited warranty is in lieu of all other express warranties, obligations, or liabilities. Any implied warranties, obligations, or liabilities, including, but not limited to, any implied warranty of merchantability shall be limited in duration to the applicable warranty period.

Any action for breach of any warranties hereunder, including, but not limited to, any implied warranty of merchantability must be brought within the applicable warranty period.

Modifications of Warranty: No agent, representative, dealer, or employee of KisanKraft Limited or any of its manufacturers has the authority to increase or alter the obligations of this warranty.

Assignment / Transfer of warranty: The warranty cannot be assigned and shall not transfer if the product is resold by the first buyer. The above warranties are extended to the first end user (original purchaser), and no warranty is made, nor authorized to be made assignable on resale by the first end user.

What you must do to obtain limited warranty service: To obtain performance of any obligation under this warranty for failure during the applicable warranty period, you must deliver the defective product, to the nearest Authorized Dealer, along with proof-of-purchase (invoice/receipt). KisanKraft Limited, its manufacturers and its dealers reserve the right to inspect the claimed defective part(s) to determine if the malfunction is the result of a defect covered by this warranty. Please note that the decision of KisanKraft Limited with respect to any warranty claim is final.

After-sales Service (Including Warranty): KisanKraft Limited does not sell directly to consumers. All sales or supplies are made through Authorized Dealers. It is the responsibility of the Authorized Dealer to provide all after-sales service to consumers. Any warranty claim should be raised by dealer to KisanKraft Limited as per warranty policy.

Jurisdiction: All disputes are subject to Bangalore court's jurisdiction.

Notes:

- This purchase is not contingent upon a product demonstration. The purchaser shall satisfy himself with the product, including any product demonstration or verification of any function, before buying. KisanKraft Limited or its authorized dealers, including online sellers, shall not be liable to give any on-site demonstration after purchase of any of the product.
- Any product once used will not be taken back by KisanKraft Limited.
- Warranty and After Sale Services (including but not limited to installation, Demonstration, Repair, Routine Maintenance etc.), should be done through the Authorized Dealer selling this product.
- Dealers should have their own technician to provide After Sales Services to their Customers. KisanKraft Limited provides free training to Authorized Dealer's technicians at KisanKraft Limited's head office, on request from Authorized Dealer.



Contents

BEFORE GETTING STARTED	7
APPLICATION	7
SAFETY INSTRUCTION AND LABELS	8
TECHNICAL SPECIFICATION	12
INSTALLATION AND USE METHODS	13
MAINTAINING METHODS	16
DEBUGGING METHOD OF INTER-CULTIVATOR	19
TROUBLE SHOOTING	20
PRODUCTS OVERVIEW	24
PARTS DIAGRAM & LIST-BODY-(KK-IC-208P / KK-IC-205P)	26
ENGINE USER MANUAL	36
ENGINE PARTS DIAGRAM & LIST	45

BEFORE GETTING STARTED

Thank you for purchasing our Inter-cultivator.

- This manual contains information on operation and maintenance of the Inter-cultivator, which is based on the most recent product information available at the time of approval for printing. We reserve the right to make amendments without prior notice and without incurring any obligation for sequences.
- No part of this publication may be reproduced without written permission.
- This manual should be considered a permanent part of the cultivator and remain with it if it is resold.
- Please pay special attention to statements preceded by the following words:

 WARNING	Indicates a strong possibility of severe personal injury or death if instructions are not followed.
 CAUTION	Indicates a possibility of personal injury or equipment damage if instructions are not followed.
NOTE	Gives helpful information.

APPLICATION

The Inter-cultivator is suitable for cultivating the sandy soil and clay soil of canopied vegetables base, slopes with gradient less than 10%, paddy field with the depth of water surface to hard layer not more than 250mm. For weedy and deep plots, remove the weeds before using the Inter-cultivator to cultivate the land. Assemble blades on both side of Inter-Cultivator and use pin to fixed blades to do Intercultural/Weeding operations. Take off resistance rod and assemble ditching blade, for ditching work.

SAFETY INSTRUCTION AND LABELS

Training

- a) Read the instructions carefully. Be familiar with the controls and the proper use of the equipment;
- b) Never allow children or people unfamiliar with these instructions to use the machine. Local regulations can restrict the age of the operator;
- c) Never work while people, especially children, or pets are nearby;
- d) Keep in mind that the operator or user is responsible for accidents or hazards occurring to other people or their property.

Preparation

- a) While working, always wear substantial footwear and long trousers. Do not operate the equipment when barefoot or wearing open sandals;
- b) Thoroughly inspect the area where the equipment is to be used and remove all objects which can be thrown up by the machine;
- c) **WARNING** – Petrol is highly flammable:
 - Store fuel in container specifically designed for this purpose;
 - Refuel outdoors only and do not smoke while refueling;
 - add fuel before starting the engine. Never remove the cap of the fuel tank or add petrol while the engine is running or when the engine is hot;
 - if petrol is spilled, do not attempt to start the engine but move the machine away from the area of spillage and avoid creating any source of ignition until petrol vapors have dissipated;
 - replace all fuel tank and container caps securely;
- d) Replace faulty silencers;
- e) Before using, always visually inspect to see that the tools are not worn or damaged. Replace worn or damaged elements and bolts in sets to preserve balance.

Operation

- a) Do not operate the engine in a confined space where dangerous carbon Monoxide fumes can collect;
- b) Work only in daylight or in good artificial light;
- c) Always be sure of your footing on slopes;
- d) Walk, never run with the machine;
- e) Exercise extreme caution when changing direction on slopes;
- f) Do not work on excessively steep slopes;
- g) Use extreme caution when reversing or pulling the machine towards you;
- h) Do not change the engine governor settings or over speed the engine;
- i) start the engine carefully according to manufacturer instructions and with feet well away from the tool(s);
- j) When start the engine, ensure the Gearshift in neutral position. Do not put hands or feet near or under rotating parts.
- k) Never pick up or carry a machine while the engine is running;

- l) Stop the engine:
 - Whenever you leave the machine;
 - Before refueling;
- m) Reduce the throttle setting during engine shut down and, if the engine is Provided with a Shut-off valve, turn the fuel off at the conclusion of working;
- n) Never load person, when starting at cobbled road sidewalk or on the road, Please keep watch, and note the traffic situation in case of the potential dangers!
- o) once abnormal condition happens, immediately close the engine! Look for the reason, vibration is often the beginning of the fault
- p) When weeding in the hard land, the blades may go low to the ground, be more careful. If happens, go off the handle bar and not go to control machine

Maintenance and storage

- a) Keep all nuts, bolts and screws tight to ensure the equipment is in safe working condition;
- b) Never store the equipment with petrol in the tank inside a building where fumes can reach an open flame or spark;
- c) Allow the engine to cool before storing in any enclosure;
- d) To reduce the fire hazard, keep the engine, silencer and petrol storage area free of vegetative material and excessive grease;
- e) Replace worn or damaged parts for safety;
- f) If the fuel tank has to be drained, this shall be done outdoors.

Matters need attention during the use of Intercultivator

- a) Operator should read this manual before using the machinery , and do the Adjustment and maintenance according to the manual.
- b) Before using the machinery, following items should be paid attention to:
- c) Please add clean fuel, make sure the engine is stopped and in well-ventilated Condition, never let fuel get in touch with high temperature surface rotating Parts or electrical components, never add too much oil in order to avoid Overflowing, if there is fuel spillage or leakage, dry it up before starting the machine, cover up fuel tank cap and tighten it. In case of fire, storage sites and venues are strictly prohibited fireworks,
- d) Check whether the bolt is fixed; any parts are loose or scratches stuck Phenomenon; whether the direction of rotation is consistent with the label mean to.
- e) Check whether external moving parts and rotating parts have reliable safety protection device and safety signs,
- f) Minors without training and master, is not allowed to operate the machine.

Safety Labels

1. Muffler is a high temperature spare part, do not touch the Inter-Cultivator in work or out of work freshly.



2. When the Inter-Cultivator is working, keep an eye on the rotary parts, do not be too close to the machine to avoid being hurt by the rotary blades.



3. Keep the components of oil box away from fire and smoke.



4. Keep this machine stabilization Before Use and Read the instruction carefully



5. Please refuel in time



6. Please pay attention to warning signs

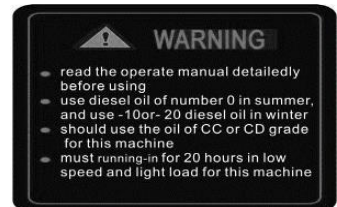

TECHNICAL SPECIFICATION

Model		KK-IC-208P	KK-IC-205P
Items		Parameter	
Engine	Rated power	4.1 kW (5.49 hp)	3.8 KW (5.1 HP)
	Engine	4 stroke, Petrol Engine	
	Displacement	208 cc	196
	Rated speed	3600 RPM	3400 RPM
	Fuel Tank	3.6L	
	Max Torque	11 Nm. /2500 RPM	
	Bore * Stroke	68*54 mm	
	Oil Tank	0.6L	
	Number of Gears	Gear drive (2 Fwd. 1 Rev)	
	Transmission	Gear transmission	
	Connection type from output shaft to blades)	Coaxial straight-through type	
cultivator	Speed (r/min)	High gear: 135; slow gear: 90	
	Knife Max radius of gyration (mm)	180	
	Blades (pcs)	24	
	Blade types used	Pair of dry lands blade, one pair of wet land blades	
	Cultivation depth (cm)	≥10	6.6-7
	Cultivation width (cm)	80	85-86
	operating speed (m/s)	0.1~0.3	
	Hourly efficiency(hm ² /hm.)	≥0.04	
	Main fuel consumption	2.165 L/hr	1.0 L/hr.

* Specifications may change due to improvements, and for reference only, not as the acceptance basis

INSTALLATION AND USE METHODS

Installation

Before sending, we did the debugging of the Main part. But before you operate it, you still need some check and adjustment, to make it to the fullest use. Since you get the inter-cultivator, assemble it as follows:

1. Fix the walking wheel to the Six squares opposite ends of the drive shaft respectively with $\phi 8$ pin
2. Assembly of trailer coupling: connect rod assembly in the trailer body, with the connecting pin shaft connection and insert the cotter pin, then insert Subsoil resistance bar.
3. Installation of handle pipe: hand the tube opposition tube slots, adjust the height, use lock handle and bolt fixed
4. Connect shift lever and fork shaft
We've done debugging before sending the products, before you use the Inter-Cultivator, you'd better check the parts and do some adjustment for better use.

Routine check

1. Check engine fuel

- Put the engine in a horizontal position
- Turn out the oil level gauge, Wipe cleanly
- Insert the oil level gauge into the oil passage hole(don't need to turn in the thread)
- Turn out the oil level gauge, check the oil lever, within the Oil scale mark can be thought as normal
- Oil SAE10W-30 is recommended as the general lubricating oil, it suitable to normal environment.

2. Check the oil of gearbox

- Put the engine in a horizontal position, turn out the oil level gauge (see picture 4)
- Normal adding oil is 1.6L, the line under the lower edge of oil filler point, if oil lever in a low lever, add to the regular lever
-

Adjustment

1. Adjust height of handle bar

- **Caution:** in order to avoid topple over, Please put the engine in flat ground before adjust the height of handle bar.(see picture 5)

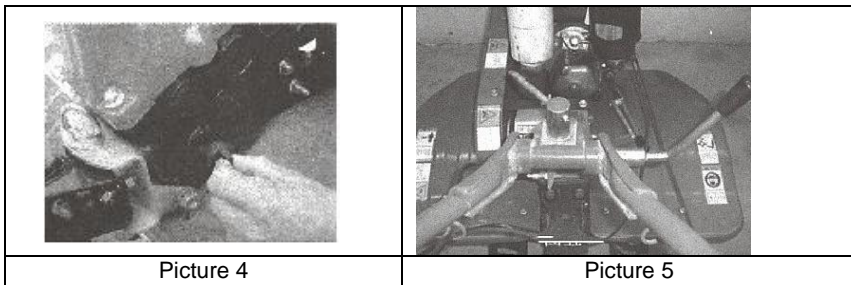

- Loosen the regulating handle, choose suitable hole, adjust the height of handle bar to a man's waist, and screw the regulating handle
- #### 2. Adjust depth of the weeding/intercultural operations
- By adjusting the height of speed control rod, control the depth of inter-cultivator, shift down, depth increase; shift up, depth decrease.
- #### 3. Start the Inter-Cultivator
- Put the inter-cultivator in neutral gear position, press down handlebar of the emergency power cut off devices, then start the machinery according to this instruction
 -
- #### 4. Adjust the clutch

Caution: reduce the speed of engine before using clutch.

- By adjusting the "separate" or "join" of clutch, to control the output of engine power.
- Grip the clutch, clutch join together, the engine power transport to the Inter-Cultivator, rotary blades begin running. (see picture 7)

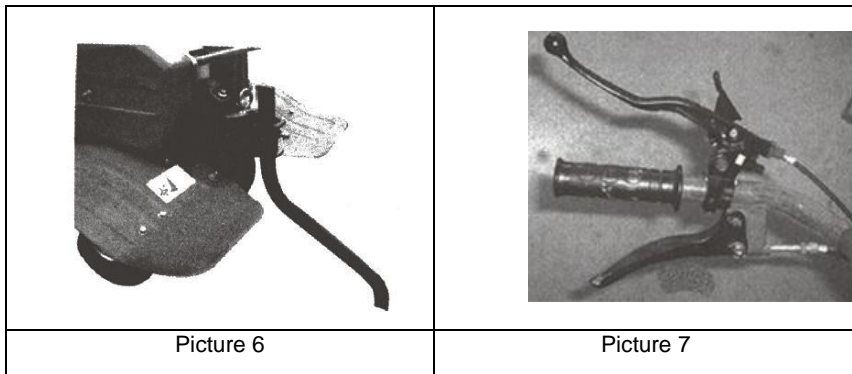

- Confirm the density of clutch cable, 4-8mm can be the general degree, out of the scope, you have to loose locknut for adjustment, and tighten up. (see picture 9)

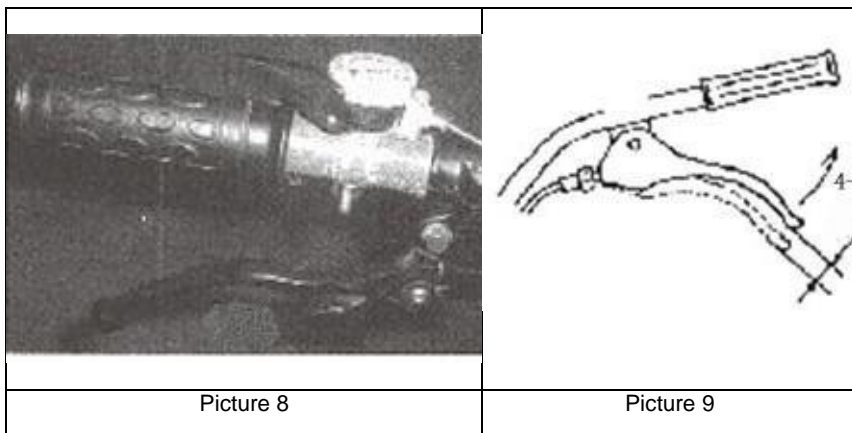

Gear shifting

- 4 gear shifting
 - The way of gear changes
- 1) Put the throttle switch to the left (a minimum position) Gear shifting by a clockwise rotation
 - 2) Loose the clutch handle to make the clutch separate
 - 3) Clench the clutch handle bar. Then the Inter-Cultivator will work on the different gear shifting, and then step on the gas to the new speed as inquired.

Reverse (-1), Forward (1), Neutral (0), Forward (2)

MAINTAINING METHODS

Because of running, friction and load change, inevitably produce connection bolt looseness, parts damage phenomenon, which make the system's correct state destroyed, the engine's power decline, fuel consumption increase, increases the normal use of Inter-Cultivator. In order to reduce the occurrence of the above situation, we must strictly, regularly do the maintenance work well. To keep the inter-cultivator machine in good technical shape and prolong its service life.

Running-in

1. The running of diesel engine Please consult its user manual.
2. new Inter-Cultivator or repaired Inter-Cultivator, should work for 1 hour in zero load condition.

After 5 hours light load working, run out the whole lubricating oil of the transmission and crankcase of diesel engine at once while the temperature is hot, and then conduct 4 hours running-in as per the fourth demands.

The technical maintenance

1. Per shift maintenance (before running and after running every time)
 - 1) Listen and observe the abnormal phenomenon(like abnormal sounds, overheating and bolt failure)
 - 2) Check the Oil leakage status of engine, transmission and walking box.
 - 3) Check the oil lever of engine and transmission, if it is within the limits of oil scale
 - 4) Timely clean the dirt, weeds, oil pollution of the Inter-Cultivator.
 - 5) Write down the inter-cultural/weeding operations record.
2. First class maintenance (ever 150 hours)
 - 1) Conduct the whole contents of per shift maintenance.
 - 2) Clean the transmission and crankcase, and change the oil
 3. Check the clutch, shift gear and reverse gear system.
3. Second class maintenance (ever 900 hours).
 - 1) Check the whole contents of working for 150hours,
 - 2) Check all the gear, bearing, if wearing serious, please change the parts.
 - 3) Other parts like rotary blades or bolt of the Inter-Cultivator, if any, please change it.
4. Technical checking (1500-2000 hours)
 - 1) Ask professional personnel to check the friction plate and clutch.
5. Maintenance of gasoline Inter-Cultivator.

The table of technical maintenance (sign means the things you need do)

Working time / contents	Every day	8 hours under the half load	20 hours later or the first month later	150 hours or the third month	1000 hours or per year	2000 hours or every 2 years
Check the bolt, nut	(
Check and add oil	(
Clean and change oil		((first time)	((second time)	((third time and afterwards)		
Check any oil leak	(
Clean the dirt, weeds, oil pollution, keep tidy	(
Remove breakdown	(
Adjust control assembly	(
Tightening belt						(
Gear and bearing					(

Storage

Never store the machine with petrol in the fuel tank in a confined area with bad ventilation. Petrol fumes could reach open flames, sparks and cigarettes etc. If the machine is to be stored for a longer period than 30 days, the following methods are recommended.

1. Empty the fuel tank.
2. Start the engine and let it run until it stops due to lack of fuel.
3. Change the engine oil if it has not been done for 3 months.
4. Remove the spark plug and empty a little engine oil (about 30 ml) in the hole. Crank the engine a couple of times. Screw back the spark plug.
5. Clean the whole machine thoroughly.
6. Lubricate all the parts as shown in LUBRICATING above.
7. Inspect the machine for damage, repair if necessary.
8. Touch up any paint damage.
9. Rust protection to the metal surfaces.
10. Store the machine indoors if possible.

DEBUGGING METHOD OF INTER-CULTIVATOR

Debugging method of mesh of bevel gear

When the abnormal transmission of mesh of bevel gear of sound is confirmed, stop the machine and check as stipulated below:

1. Clearance adjustment of mesh of angel gear in gear-box (See Figure 10)

① When lateral clearance of mesh of the gear $\Delta < 0.05\text{mm}$, we should put some vulcanized paper to enlarge the clearance between the gear-box and the traveling box.

② When lateral clearance of mesh of the gear $\Delta > 0.3\text{mm}$, we should reduce the clearance to 0.05-0.10 mm between the bearings and gear II shaft

2. Clearance adjustment of mesh of the gear in the running case. (See Figure 11)

When lateral clearance of mesh of the gear

$\Delta < 0.05\text{mm}$, we should increase adjustment pad I by 0.2-0.3mm to enlarge the clearance, and change vulcanized paper board II and adjustment pad.

3. To ensure the axial clearance of the gear II is 0.05-0.15mm.

When lateral clearance of mesh of the gear

$\Delta > 0.3\text{mm}$, we should reduce adjustment pad I, meanwhile the axial clearance of gear II is 0.05-0.15mm, or increase the adjustment pad II, meanwhile ensure the axial clearance

of gear I is 0.05-0.15mm.

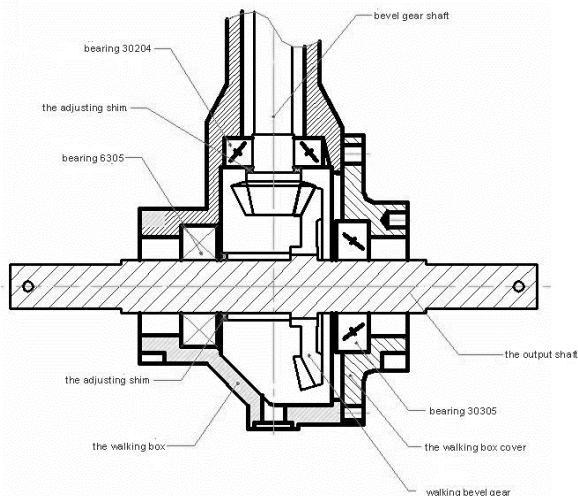
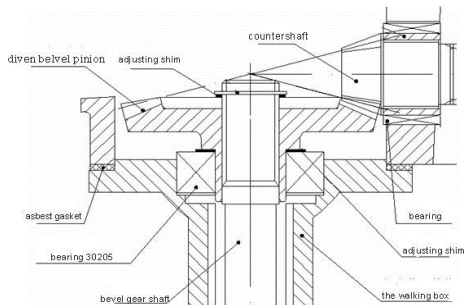

TROUBLE SHOOTING

Clutch's faults and methods

Phenomenon	Reasons	Methods
Clutch failure	Failure of clutch handle bar	Fix or replace
	Failure of clutch cables	Change
	Shifting fork not on the position	Readjustment or replace
	Drop of shift shaft, arm set	Fix or replace
	Break of shift fork	Replace
	□spring failure	Replace
Slip(loose the clutch handle bar, the engine works well, but the transmission slow-turning or stop working)	□spring fatigue failure	Replace
	Shift shaft turning ineffective, which make the shifting fork not on the right place	Clean the surface of locating shaft and shuffle disc
	Clutch cable maladjustment	Readjust the clutch cable

Gearbox's faults and methods

Symptom	Cause	Terms of settlement
Failure of fast, slow and neutral shift	Bolts and nuts for the main shaft are loose	Dismount the bolts, keys cover at the back of the main shaft, screw the round nuts tight, then fix back the bolts and keys cover and screw them tight
	Excess abrasion of puller	Replace the puller
Failure to shift to the right position	Driving loose angle gear is Tighten the round nuts	
	Excess abrasion of the upper hole in the connection piece of support arm	Replace the support arm assembly
	Positioning spring inside the main shaft does not function	Replace
	Main shaft is moving ,the bolts for tightening the cover for the rear of the gear-box body are loose	Screw the bolts tight
The reversing shaft is loose	Rear bolts of reversing shaft are loose	Screw the reversing shaft
	The matching between reversing shaft and gear-box body is too	Replace
Too much noise from the gears	Deformation and bend of the angle gear and reversing shaft	Replace

	Too much lateral clearance due to excess abrasion of gears		Replace the gears
	The matching between bevel gear and reversing shaft and gear-box body is too loose		Replace
	Deformation of shift bar brings about interference when you shift	Adjust the shift bar or Replace it	Adjust the shift bar or Replace it
	Abrasion of reversing fork	Re-adjust the cable of reversing shift	Re-adjust the cable of reversing shift
	Malfunction of reversing Replace the reversing fork		
Failure to shift the	cable Replace the cable		
reversing shift to the right position	the reversing shaft is loose		Screw the bolts tight at the back of the reversing shaft
	The reversing fork is blocked to a standstill		Clean the combined face between reversing fork and reversing pushing plate to make the fork move freely
	The loosening of reversing shaft makes the gear be blocked to a standstill		Screw the bolts tight at the back of the reversing shaft.

	Malfunction of spring of the reversing shaft	Replace the spring
The reversing gears do not reset	The reversing shaft is bent and deformed	Replace the reversing shaft

Faults and methods of walking system

Phenomenon	Reasons	Methods
Gear's noise too loud	excessive wear or wrong fix	Reassemble or replace
Rotational hairpin of gear	Wrong assembling	Reassemble
Excessive fever	Too little lubricating oil	Add oil as per demands
Oil leak of output shaft sleeve cylindrical surface	Oil seal is damaged	Change oil seal
Serious oil leak of output shaft sleeve	Sleeve fracture	Replace
Oil leak of oil drain	O-rings damaged	Change
	Bolt loose	Tightening
Oil leak of crankcase	Crankcase has micro loose hole	Welding or priming

Other failures

Phenomenon	Reasons	Methods
Break-in of blades	Plough into rock or other flip	Replace it, and pay attention to avoid crash with hard objects like stone
Control cable break-in	Long-term wearing	Replace

PRODUCTS OVERVIEW

1. Emergency power cut off devices
2. Handle bar
3. Gear box
4. 170F gasoline engine
5. Fender
6. Trailer body
7. Drag strut
8. Gear lever
9. Reverse gear handle
10. Clutch handle

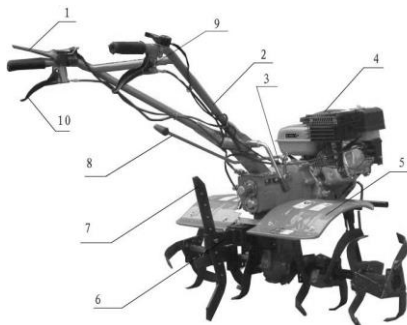

Machine List for Matching

Attached Tools

Series	Name	Unit	Application
1	Dry field blades	Set	Dry-land cultivation
2	Paddy field wheel	Set	Paddy field cultivation
3	2 piece-4 unit anti-wind knife	Set	Wetland farming with too much grass
4	3 piece-4 unit anti-wind knife	Set	
5	Efficient paddy field wheel	Set	Paddy field cultivation
6	Flood composite knife	Set	Dry-land, paddy field cultivation
7	Crawl plate	Set	Used for climbing

Easily Damaged Parts List

Series	Parts	Work Site	Series	Parts	Work Site
1	Spark Plug	Engine	9	The Filter Elements	Engine
2	Stop Switch	Engine	10	Kinds Of Spring	Engine Gear Box
3	Oil Plug	Engine	11	Paper Pad	Engine Gear Box
4	Piston Roll	Engine	12	Oil Seal, Oil Cover, O-ring	Engine Gear Box
5	Oil Tube	Engine	13	Bearing	Engine Gear Box
6	Connecting Rod Bearing Shell	Engine	14	Chain	Gear Box
7	Inlet Exhaust Valve Rocker Arm	Engine	15	Kinds Of Cable	Machine Frame
8	Start Pull Plate	Engine	16	Pin Roll, Cotter Pin	Cylinder

PARTS DIAGRAM & LIST-BODY-(KK-IC-208P / KK-IC-205P)

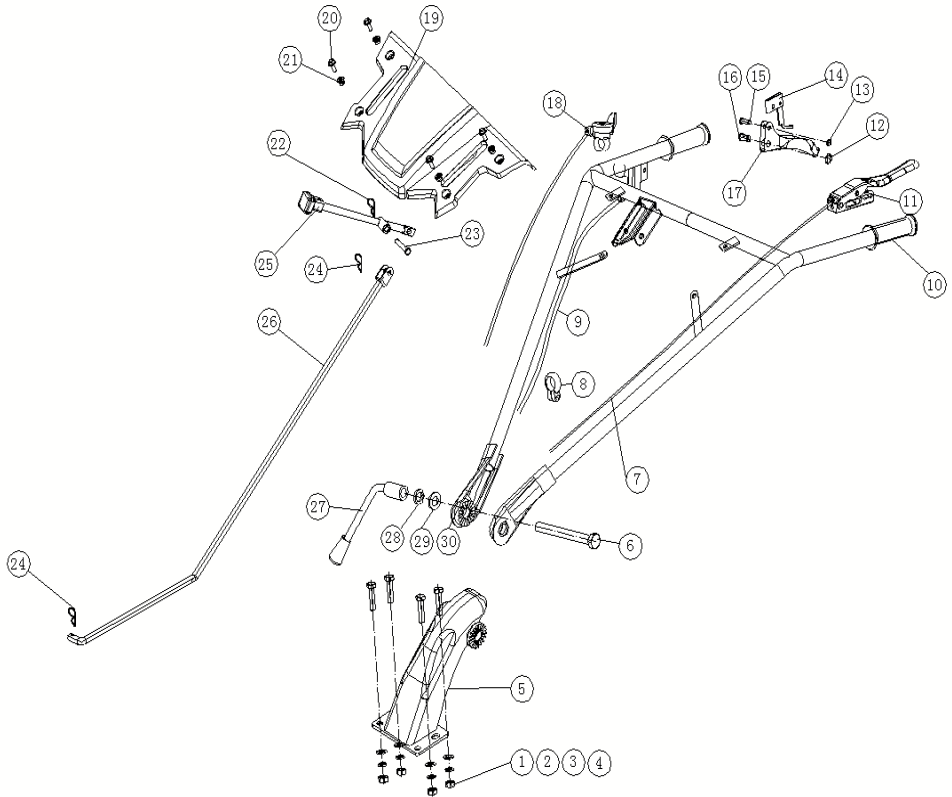

Series No.	Part Code	English Name	Quantity for One Unit
1	B16674-1-10MG-030A	HEXAGON FLANGE BOLT	4
2	B93-100G-000A	Spring Washer ϕ 10	4
3	B95-100G-000A	Flat Washer ϕ 10	4
4	B6170-10MG-000A	HEXAGON FLANGE NUTS ϕ 10	4
5	73201-T90A-B0RQ	Handle Seat	1
6	B5782-16PG-150A	HEXAGON FLANGE BOLT	1
7	73112-T90A-3101	Clutch cable	1
8	7141B-TA5C-1000	Wire fixing device	2
9	73139-T90C-3000	reverse cable	1
10	73002-TA5A-1000	Rubber sleeve	2
11	73111-TA5A-5200	Clutch handle	1
12	B896-010-000B	Blocking circle	1
13	B896-006-000B	Blocking circle	1
14	73123-TA5A-000C	reverse block Assy	1
15	73113-TA5A-000A	Handle pin	1
16	73114-TA5A-000A	pull pin	1
17	73121-TA5A-00B5	reverse handle	1
18	73104-T90A-4000	throttle switch assembly	1
19	73115-TA5A-11RW	tool box	1
20	B5789-06KG-016C	HEXAGON FLANGE BOLT	4
21	B6177-1-06KG-000C	hex flange face lock nuts	4
22	72205-TA5A-000C	R spilt pin	2
23	B882-0080-050C	B PIN 8x40	1
24	72205-TA5A-000C	R spilt pin	1
25	73001-T90A-06B5	shift lever	1
26	73001-T90A-13B5	shift lever	1
27	73003-TA5A-000A	high and low locking handle	1
28	B93-160G-000A	Spring washer	1
29	B95-160G-000A	Flat Washer	1
30	73101-T90A-75W2	Handle	1

Gear Shaft Diagram

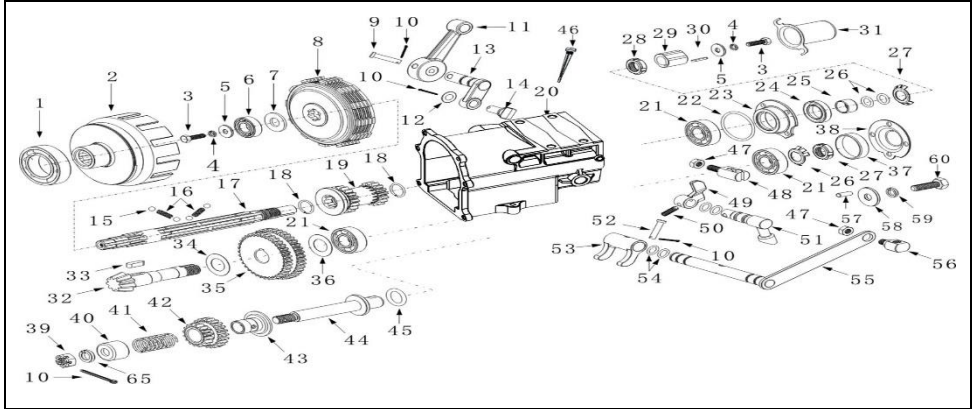

Series No.	Part Code	English Name	Quantity for One Unit
1	B276-6007-00	Bearing6007	1
2	71310-T90A-0004	Cover, clutch	1
3	B5783-06KG-020A	HEXAGON FLANGE NUTS M6*P1*20	1
4	B862.2-060G-000B	Lock Washer	1
5	B5287-060G-000A	Big Washer φ7	1
6	B276-6202-00	Deep groove ball bearing 6202	1
7	71109-155H-0000	Clutch washer	1
8	71320-T90A-2000	Core comp, clutch	1
9	B882-0060-040A	Pin6x40,Shift Rod	1
10	B91-0016-020C	Clipφ2	1
11	71143-TA5A-000A	Sheath, Shift Rod	1
12	B3452.1-180C-0100	O seal (Φ1.8*Φ10)	2
13	71141-TA5A-000A	Shift Axes	1
14	71142-TA5A-000B	Shift fork	1
15	B308-0600-0000	Steel ball Sφ6	1
16	71115-T90A-000B	Spring ,principal axes	1
17	71111-T90A-0000	Principal axes	1
18	B895-2-0020-000B	Round wire snap rings for shaft 20	2
19	71112-T90A-0000	Indicative gear	1
20	71500-T90A-00R9	Shift Gear box	1
21	B276-6203-00	Deep groove ball bearing Φ17*Φ40*12	1

22	B3452.1-180C-0400	O seal (Φ1.8*Φ40)	1
23	71107-T90A-000A	Main shaft gland Q235	1
24	B9877.1-020C-3500	Oil seal (Φ20*Φ35*7)	1
25	71113-T90A-0000	Main shaft bushing (45#/φ16*φ20*12.5)	1
26	B3452.1-180C-0132	O seal (Φ1.8*Φ13.2)	2
27	B858-016G-000B	Gasket (Φ16.5*Φ22*1)	1
28	B812-16MG-000B	Round nuts M16	1
29	71114-T90A-0000	Spindle key sleeve	1
30	71116-T90A-000B	Flat key (35/5*5*18/)	1
31	71108-T90A-000A	Spindle shield	1
32	71121-T90A-0000	Countershaft	1
33	71116-TA5A-0000	Flat key(35/6*6*20)	1
34	71109-250K-000B	adjusting shim	1
35	71123-T90A-0000	Double gear, countershaft	1
36	71109-220K-000B	adjusting shim	1
37	73006-TA0A-0000	Seal gasket	1
38	7110C-TA0A-100A	Tail-hood	1
39	B6181-12NG-000A	Nut M12	1
40	71134-TA5A-0000	Restrict cover, reverse gear	1
41	71136-TA5A-000B	Spring seat, reverse gear	1
42	71132-T90A-0000	Double gear, reverse gear	1
43	71133-TA5A-0000	Pushing plate, reverse gear	1
44	71131-TA5A-0000	Axes, reverse gear	1
45	B3452.1-180C-0180	O-ring18×1.8	1
46	11010-E68F-2000	Oil stick	1
47	B6170-08LG-000A	Nut M8	1
48	71105-TA0A-000A	Seat, reverse gear cable	1
49	71152-T90A-000B	Reverse gear fork	1
50	B5780-05KJ-025A	HEXAGON FLANGE NUTS	1
51	71151-T90A-000A	Axes, ever gear fork	1
52	B882-0060-025A	Pin6×25,cluth fork	1
53	71162-T90A-000B	Clutch fork	1
54	B3452.1-180C-0100	O-ring18×1.8	2
55	71161-T90A-000A	Axes, clutch fork	1
56	71163-T90A-000A	Seat, clutch cable	1
57	B119.1-0050-0100	Pin A5×10	1
58	B95-120G-000A	Flat washer (Φ13.5*Φ24*2.5)	1
59	B93-120G-000A	Spring Washer12	1
60	B5782-12MJ-025A	HEXAGON FLANGE NUTS M12*25)	1

Transmission case Part

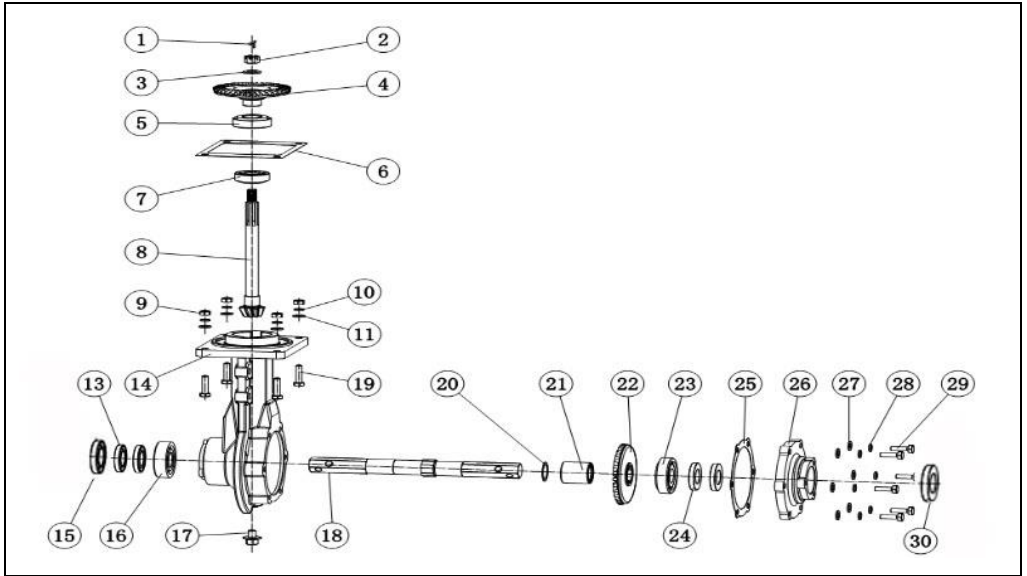

Series No.	Part Code	English Name	Quantity for One Unit
1	B91-0025-025A	Splitpin 2.5x22	1
2	B6181-12NG-000A	Nut M12	1
3	B93-120G-000A	Spring Washer 12	1
4	71212-T90A-0000	Driven umbrella gear	1
5	B297-30205-00	Taper ball bearing 30205	1
6	71005-T90A-2000	paper pad	2
7	B297-30204-00	Taper ball bearing 30204	1
8	71211-T90A-0000	Umbrella gear axes	1
9	B6170-10LG-000A	Nut M10	4
10	B93-100G-000A	Spring Washer 10	4
11	B95-100G-000A	Washer 10	4
13	B9877-1-025C-4700	Oil Seal 25x47x7	2
14	71201-T90A-00RQ	Walking case	1
15	71006-T90A-200A	dust shield	1
16	B276-6305-00	Bearing 6305	1

17	71204-TA5A-200B	BoltM12x1.25x10	1
18	71008-T90A-0000	Flange output axes	1
19	B5783-10MG-040A	Bolt M10x40	4
20	71109-350K-260B	Washerφ26*φ34*0.5	2
21	71223-T90A-0000	Cover,output axesφ26*φ34.5*37.5	1
22	71221-T90A-0000	Walking umbrella gear	1
23	B297-30305-00	Taper ball bearing30305	1
24	B9877-1-025C-4700	Oil Seal 25x47x7	2
25	71203-T90A-0000(71203-T90A-1000)	Side cover gasketδ0.2/δ0.5	1
26	71202-T90A-00RQ	Side cover	1
27	B95-080G-000A	Washer8	6
28	B93-080G-000A	Spring Washer8	6
29	B5783-08LG-023A	Bolt M8x30	6
30	71006-T90A-200A	dust shield	1

Blades Assembly

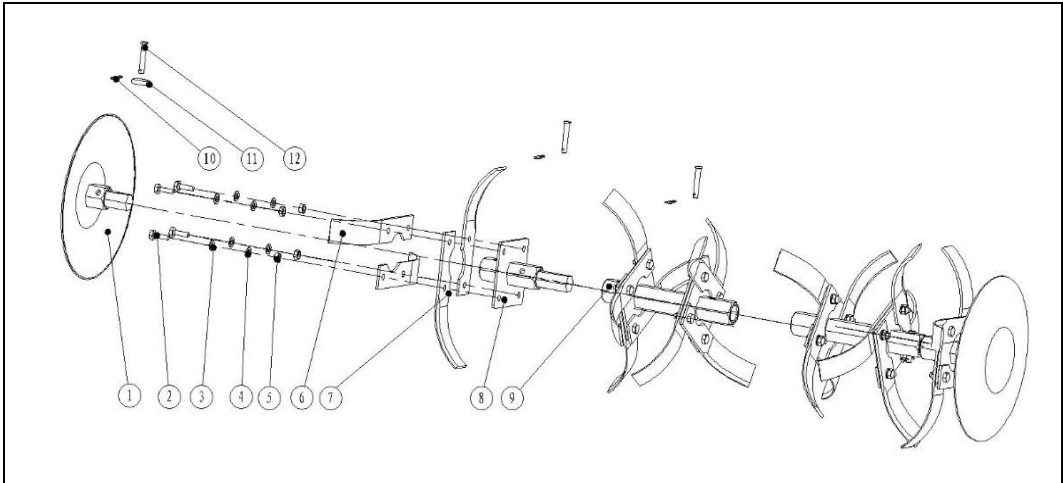

Series No.	Part Code	English Name	Quantity for One Unit
1	79512-T80A-51B5	DISC	2
2	B5782-08MG-030C	HXAGON FLANGE BOLTM8x30	24
3	B95-080G-000C	WASHER 8	24
4	B93-080G-000C	WASHER SPRING 8	24
5	B6170-08MG-000C	HXAGON FLANGE NUT M8	24
6	79114-T80A-01B5	Blade (R)	12
7	79113-T80A-01B5	Blade (L)	12
8	79112-T80A-0100	VICE BLADE CYLINDER	2
9	79111-T75A-0000	BLADE CYLINDER	2
10	72205-TA5A-000C	βPINφ2×9×38	6
11	B95-080G-000C	WASHER 8	6
12	B882-0080-040C	B PIN 8x40	6

WHEEL ASSY

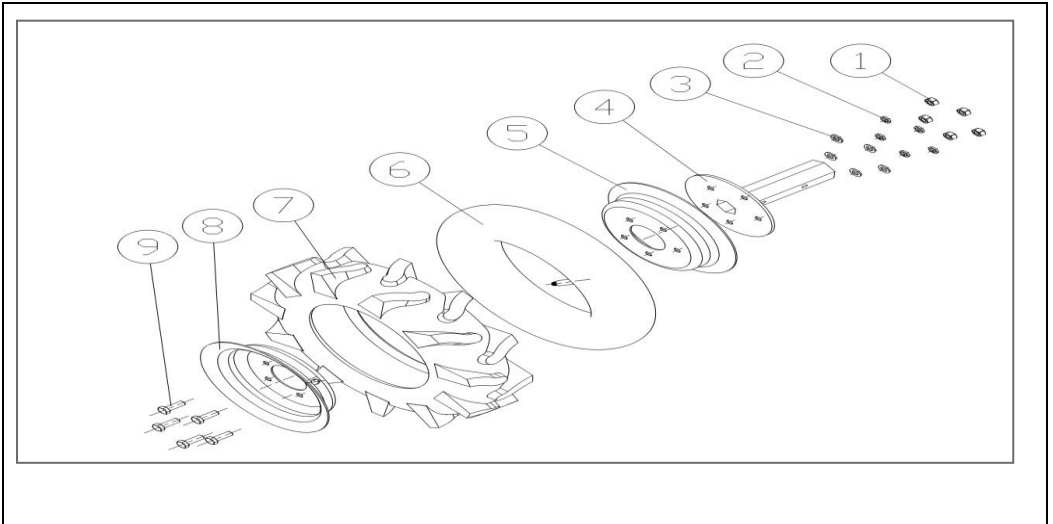

Series No.	Part Code	English Name	Quantity for One Unit
1	B6170-10MG-000A	HEXAGON FLANGE NUTSM10	0
2	B93-100G-000A	WASHER SPRING 10	16
3	B95-100G-000A	WASHER 10	16
4	75115-TA5A-21B5	WHEEL SHAFT	2
5	75113-TA5A-00W2	INSIDE WHEEL HUB	2
6	75112-TA5A-0000	INNER TUBE 4.00-8	2
7	75111-TA5A-0000	OUTTER TUBE 4.00-8	2
8	75113-TA5A-00W2	OUTSIDE WHEEL HUB	2
9	B5783-10MG-020A	HEXAGON FLANGE BOLTM10x20	8
10	B5783-10MG-025A	HEXAGON FLANGE BOLTM10x25	8

Assembly

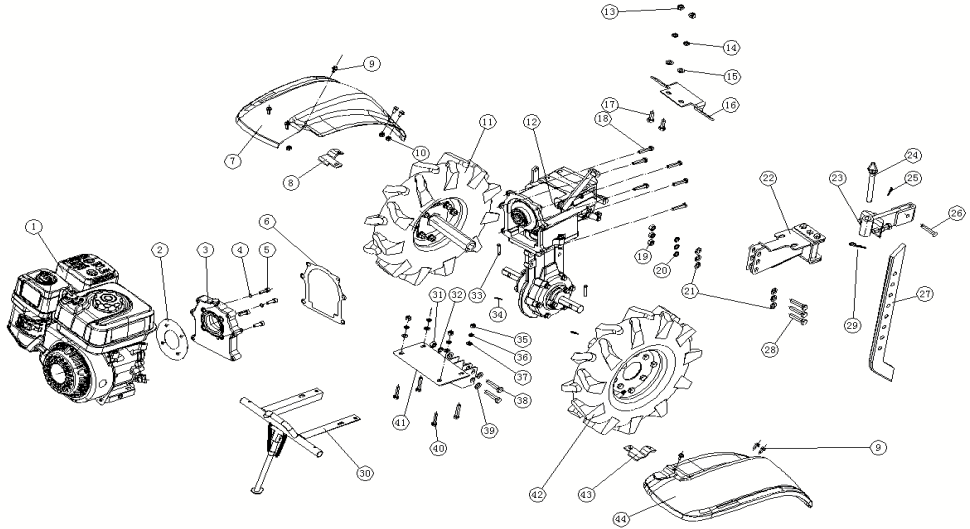

Series No.	Part Code	English Name	Quantity for One Unit
1	10000-E70F-D194	170 FB engine	1
2	71004-T90A-1000	Flange gasket	1
3	71001-T90A-00RQ	Flange Assy	1
4	B93-080G-000A	Spring washer	7
5	B70-1-08LG-025A	Screw M8*P1.25*25	7
6	71003-T90A-1000	Paper gasket, gear box	1
7	74111-T90A-20RQ	Fender right	1
8	74122-T90A-50B5	Fender support	1
9	B5789-06KG-016C	HEXAGON FLANGE BOLTM	4
10	B6177-1-06KG-000C	HEXAGON FLANGE NUTS	4
11	75110-T90A-62W2	right wheel Assy	1
12	71000-T90A-31RQ	transmission Assy	1

13	B6170-10LG-000A	nuts M10	2
14	B93-100G-000A	WASHER SPRING ϕ 10	2
15	B95-100G-000A	WASHER ϕ 10	2
16	74121-T90A-30B5	fender backside support	2
17	B5783-10MG-025A	HEXAGON FLANGE BOLTM	2
18	B16674-1-08LG-040A	HEXAGON FLANGE BOLTM	2
19	B6170-10LG-000A	nut M10	3
20	B93-100G-000A	WASHER SPRING ϕ 10	3
21	B95-100G-000A	WASHER ϕ 10	6
22	72201-TA0A-02B5	Coupling	1
23	72202-TA5A-12B5	Connector	1
24	72203-TA5A-000A	PIN	1
25	B882-0080-040A	β PIN ϕ 8*40	1
26	72205-TA5A-000A	β PIN ϕ 2*9*38	1
27	72204-TA5A-00B5	DEEP FURROWING RESISTANCE PART	1
28	B5789-10KG-045A	HEXAGON FLANGE BOLT M10*P1.5*45	1
29	72205-TA5A-010A	β PIN	1
30	72110-T90A-00B5	bumper Assy	1
31	B6170-10LG-000A	nuts M10	2
32	B93-100G-000A	WASHER SPRING ϕ 10	2
33	B882-0080-040A	B PIN 8x40	2
34	72205-TA5A-000A	β PIN ϕ 2*9*38	2
35	B6170-10LG-000A	nut M10	4
36	B93-100G-000A	WASHER SPRING ϕ 10	4
37	B95-100G-000A	WASHER ϕ 10	4
38	B5789-10KG-040A	HEXAGON FLANGE BOLTM	2
39	B95-100G-000A	WASHER ϕ 10	4
40	B5789-08KG-045A	HEXAGON FLANGE BOLTM	4
41	72101-T90A-00B5	ENGINE SUPPORT	1
42	75110-T90A-5000	left wheel Assy	1
43	74122-T90A-40B5	fender support left	1
44	74112-T90A-20RQ	left fender	1

ENGINE USER MANUAL



BEFORE GETTING STARTED

Thank you for your purchase and use of our products. In order to avoid accidents or injury, **please read this manual carefully** before using the machine. After reading, preserve it for further reference. This manual is a part of the gasoline engine and should be transferred when the machine is resold.

SAFETY LABELS



Indicates a hazard, if not avoided, can result in human injury or death.



Indicates a hazard, if not avoided, could result in human injury and/or property damage.

CAUTION

Indicates a hazard, if not avoided, might result in slight injury and/or property damage.



Please read and understand this owner's manual before operation of the engine to avoid accidents by familiarizing yourself with your engine's controls and safe operation procedures.

SAFETY INSTRUCTIONS

1. Please perform some pre-operation checks before operation to avoid human injury and equipment damage.
2. Keep the engine in good, ventilated places at least 1 meter away from buildings and other equipment's during operation and keep the flammable substances away from the engine to avoid fire.
3. Keep children and pets away from the operation area.
4. Make sure that the person who operates the engine receives proper instruction.
5. Keep the flammable substances (gasoline, matches) away from the operating engine.
6. As gasoline is extremely flammable and explosive under certain conditions, please refuel in a well-ventilated area with the engine stopped.
7. Do not fill above the shoulder of the fuel strainer.
8. Make sure the fuel cover is tightened.
9. Make sure that any spilled fuel has been wiped off before starting the engine.
10. Do not smoke or allow flames or sparks where the engine is refueled or where gasoline is stored.
11. Exhaust contains poisonous carbon monoxide, a colorless and odorless gas. Breathing exhaust can cause loss of consciousness and may lead to death. Do not operate the engine without good ventilation or in enclosed room.
12. If you run the engine in an area that is confined, or even partially enclosed, the air you breathe could contain a dangerous amount of exhaust gas. Provide adequate ventilation so as to keep exhaust gas from accumulation.
13. Place the engine on flat (level) surface, tilting angle of the engine should not be more than 20°, otherwise it will lead to fuel spilling out.
14. Do not cover the engine so as to avoid fire occurrence.
15. The muffler becomes very hot during and immediately after operation. Be careful not to touch the muffler while it is hot. Let the engine cool down before storing the engine indoor.

PRE-OPERATION CHECKS

Check the oil level

Lubricating oil:

- Engine lubricant oil is a major factor affecting engine performance and service life.
- The use of the lubricating oil free of cleaning agent or the lubricating oil for the two-stroke engine will shorten the life of the gasoline engine.
- The operating temperature range recommended for the gasoline engine is -5°C~40°C.
- Use 4-stroke motor lubricant oil. 20W-40 is recommended in general, at all temperature use. Other viscosities shown in the chart may be used when the average temperature in your area is within the indicated range.

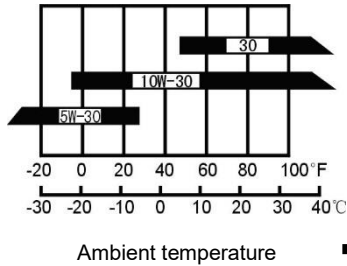

- Before checking engine lubricant oil, place the engine on level surface
- Turn out the oil filler cap and clean the dipstick with a clean cloth.
- Insert the dipstick back into the oil filler hole without turning it in.
- If oil level is below the lower mark of the dipstick, fill oil to the upper level of the dipstick.
- Reinstall the oil filler cap properly.

Upper level

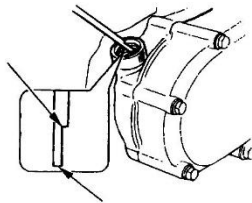

Lower level

Dipstick

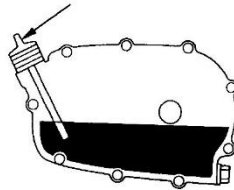

Engine oil alert system (optional function):

The oil alert system is designed to prevent engine damage caused by insufficient oil in the crankcase. When the oil level in the crankcase falls below the safe limit, the oil alert system will automatically stop the engine even if the engine switch remains at the ON position. If the engine stops and cannot be restarted, check the engine oil level before troubleshooting in other areas.

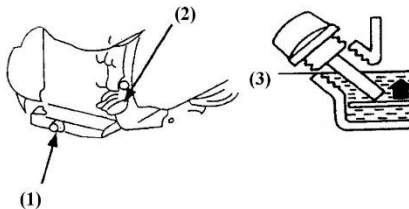

(1) Drain plug

(2) Engine switch

(3) Lower level

Fuel level

- Check the fuel gauge, and refill the tank if the fuel level is low. Do not fill above the shoulder of the fuel strainer. The fuel 90# gasoline is recommended.
- Unleaded gasoline produces less engine and spark plug fouling and extends exhaust system life.
- Never use stale or contaminated gasoline or oil/gasoline mixture. Avoid dirt, rubbish and water from getting into the fuel tank.
- If spark knock or pinging occurs at a steady engine speed under normal load, change brands of gasoline. If spark knock or pinging persists, see an authorized dealer.

! WARNING:

- Running the engine with persistent spark knock or pinging can cause engine damage.
- If persistent spark knocks or pinging is caused by improper usage of the unit, the Distributor's Limited Warranty does not cover parts damaged by that.

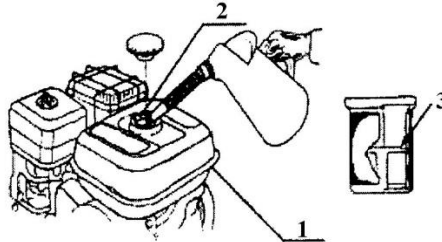

(1) Fuel tank

(2) Fill in hole

(3) Red line level

Air cleaner

The air cleaner is a dry type including paper element and foam element.

- Remove the clip and dismantle the air cleaner housing or remove the wing nuts and air cleaner cover.
- Wash the element in solution of household detergent and warm water, then rinse thoroughly, or wash in nonflammable or high flash point solvent. Allow the element to dry thoroughly

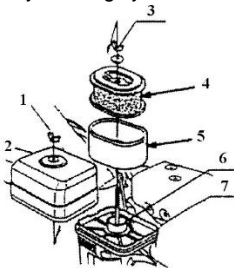

- 1) Butterfly nut
- 2) Air cleaner cover
- 3) Butterfly nut
- 4) Paper element
- 5) Foam element
- 6) Seal washer
- 7) Silencer plate

! WARNING:

Do not run the engine without air cleaner.

! DANGER

Using gasoline or flammable solvent to clean the filter element can cause a fire or explosion.

! CAUTION:

Do not run the engine without air cleaner core, otherwise dust and/or other foreign matters may get into the engine through carburetor, and results in rapid engine worn-out.

STARTING THE ENGINE

- Turn the fuel valve to ON position, unscrew the drain plug on carburetor bottom, and fasten the drain plug until oil spills out.
- Pull the choke rod to the CLOSE position. Adjust throttle to proper position. Pull the starter grip lightly until resistance is felt, then pull it rapidly

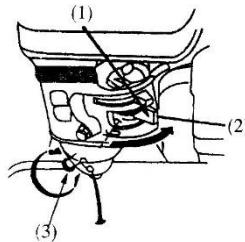

(1) Fuel Valve

(2) Start Level

(3) Drain Plug

NOTE:

- Do not allow the starter grip to snap back against the engine. Return it gently to prevent damage to the starter.
- Once the engine got started, let it run for 1~3 minutes at idle speed, check whether it is balanced, cracked, then pull the throttle to open position, adjust choke rod to OPEN.

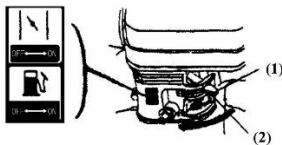

(1) Auto-Throttle

(2) Off Position

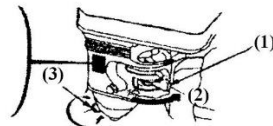

(3) Starter Knob

Electrical Starting:

Turn the engine switch to START position and hold a while until the engine started

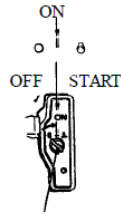

ENGINE SWITCH

NOTE: Restrict the starting time within 5 seconds to avoid engine damage. If engine cannot be started, release starter knob, retry after 10 seconds.

STOPPING THE ENGINE

Adjust throttle to proper position. Reduce engine speed, close the choke. Turn engine switch to OFF position.

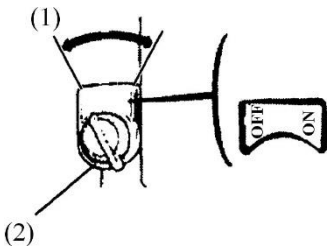

(1) Throttle knob

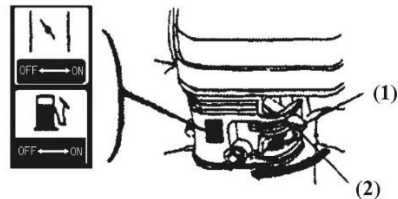

(2) Throttle is at OFF

! DANGER:

- Gasoline is extremely flammable and explosive under certain conditions.
- Refuel in well-ventilated places with the engine stopped. Do not smoke or allow flames or sparks near the places where the engine is refueled or gasoline is stored.
- Do not add fuel over the shoulder of strainer. After fueling, tighten the tank cover.
- Fuel vapors are extremely flammable and may ignite after the engine has started. Make sure that any fuel spillage has been wiped off before starting the engine.
- Avoid skin coming in contact with gasoline for a long time, avoid breathing in gasoline vapors. Keep children away from them.

NOTE:

Fuel can damage paint and plastics. Be careful when refueling. Damage caused by spilling fuel is not covered under warranty.

MAINTENANCE

Do periodic maintenance to keep the engine in good condition. Always follow the inspection and maintenance recommendation and schedules given in this manual.

! WARNING:

Stop the engine before doing any maintenance work. If the engine must be operated, provide adequate ventilation. Breathing in exhaust can cause loss of consciousness and even lead to death.

Everyday Maintenance:

1. **Air cleaner:** A dirty air cleaner will restrict air flow into the carburetor. To prevent carburetor malfunction, service the air cleaner regularly. Service more frequently when operating the generator in extremely dusty areas.
 - Check air cleaner core, get rid of fouling, and keep the core clean.
 - Check bolts, fasten the loose ones.
 - Check whether lubricant oil level is within the limits.
2. Clean the core after 25hrs of engine run
3. Clean carbon fouling of the spark plug after working up to 50hrs. Check the clearance, and adjust the gap to 0.6-0.7mm (see figure 4-1). Check radiator, and clean fouling among radiators.
 - Drain the oil while the engine is warm to assure rapid and complete draining.
 - Remove the drain plug and sealing washer, remove the oil filler cap, and drain the oil.
 - Reinstall the drain plug and sealing washer. Tighten the plug securely.
 - Refill with the recommended oil and check the oil level.

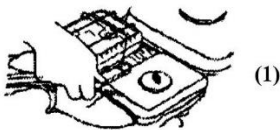

(1) Dismantle Spark Plug

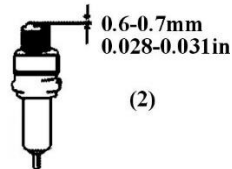

(2) Adjust Clearance

4. Clean the fuel tank and filter when working time reaches 100hrs: Remove the fuel cover, drop out filter, and wash it with brush slightly. Remove fuel tank, clean the fouling and water inside fuel tank. Reinstall fuel tank, place filter from fill-in hole, filling the clean fuel to red line level.

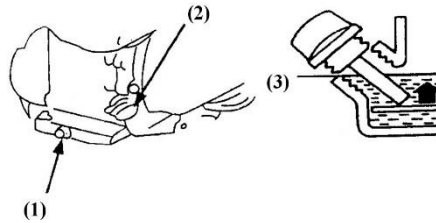

- 1) Drain plug 2) Engine switch 3) Lower level

Check aging of fuel pipe every 2 years. If ageing, hardening and cracking is detected, have it replaced. Tighten the joints, and check leakage.

Before storing the unit for an extended period:

1. Make sure the storage area is free of excessive humidity and dust.
2. Service according to the table below.

Storage Time	Recommended Service Procedure To Prevent Hard Starting
Less than 1 month	No preparation required
1 to 2 months	Fill with fresh gasoline and add gasoline conditioner
2 months to 1 year	<ul style="list-style-type: none"> • Fill with fresh gasoline and add gasoline conditioner • Drain the carburetor float bowl • Drain the fuel sediment cup

STORAGE

If the engine is not used for a long time, do the necessary maintenance before its storage.

- Firstly, take off the fuel tank, drain out all fuel, and clean the dirt and water inside the tank. Open the fuel cock, unscrew the drain plug at the bottom of carburetor, drain out fuel in carburetor thoroughly, and then tighten the drain plug.
- Secondly, unscrew the drain plug at the bottom of the crankcase and drain out the lubricant oil in the crankcase thoroughly, then tighten the drain plug.
- Finally, clean the surface of the engine with clean cloth, remove the dirt and dust etc. Then store the engine in a well-ventilated, dirt-free place.

TRANSPORTATION

- Contact with the hot engine or exhaust system can cause serious burns or fires. Allow the engine to cool down before transporting or storing the engine.
- During transport of the engine, turn the engine switch and the fuel valve to OFF. Keep the engine cool.

TROUBLESHOOTING

1. The Engine Can't Start

- Have the engine checked if it is hard to or cannot be started.
- Firstly, check the fuel level of the fuel tank. Turn fuel valve to (2), Fuel should flow from the drain when the fuel valve is turned ON. Tighten the drain plug. (Refer to starting of the engine)

2. Spark Plug

Check the spark plug. Remove the spark plug cap and clean any dirt around it. If the engine still cannot be started after repeating several times, please see the authorized dealer. Users are not allowed to dismantle or reassemble the unit by themselves.

3. Not Enough Power

- Check the air-cleaners. Please refer the maintenance inspection book to clear the air-cleaner.
- Check the fuel. Please strain out the gasoline in fuel tank and in carburetor, and fill in new gasoline.
- For any other trouble, please contact our dealer.

ENGINE PARTS DIAGRAM & LIST

Cylinder Head

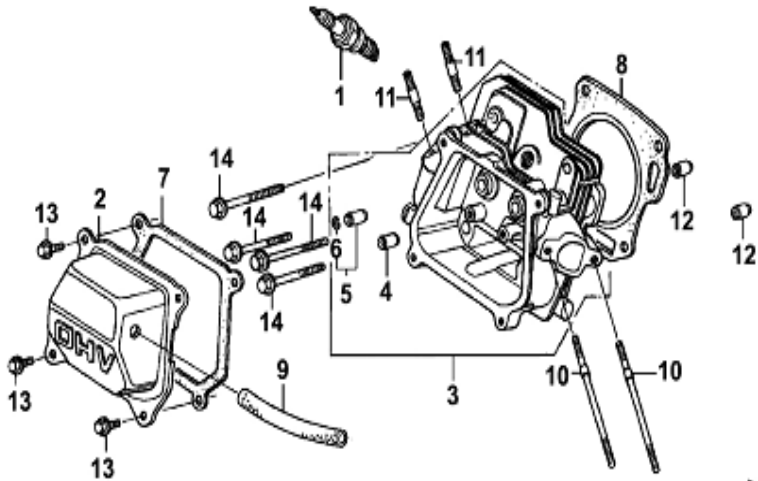

SL-No	KK-No	KK-Name	Qty
1	E3-01	Spark plug	1
2	E3-02	Cylinder head cover	1
3	E3-03	Cylinder head Assy	1
4	E3-04	In. valve guide	1
5	E3-05	Ex. valve guide	1
6	E3-06	Valve guide clip	1
7	E3-07	Gasket Cylinder head cover	1
8	E3-08	Gasket Cylinder head	1

SL-No	KK-No	KK-Name	Qty
9	E3-09	Air duck/Pipe	1
10	E3-10	Stud Intake Port M6 x 113	2
11	E3-11	Stud Exhaust Port M8 x 32	2
12	E3-12	Set pin 10x14	2
13	E3-13	Bolt M6x12	4
14	E3-14	Bolt M8 x 60,	4

Crankcase Assembly

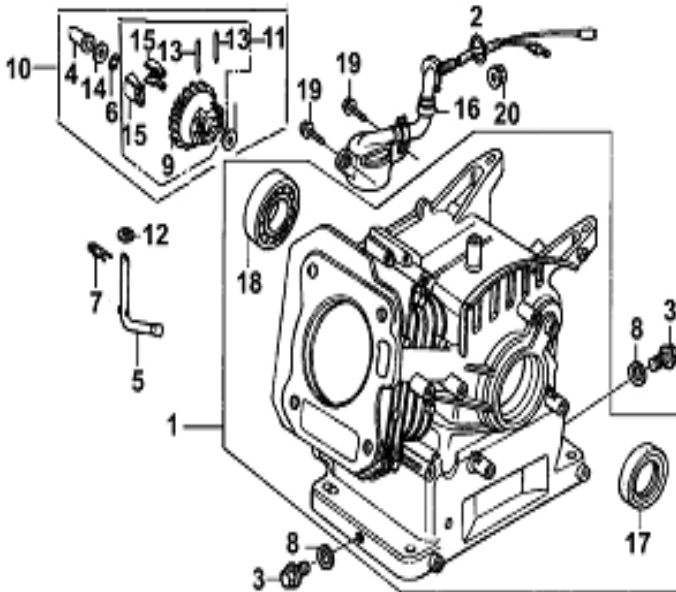

SL-No	KK-No	KK-Name	Qty
1	E4-01	Crankcase Body	1
2	E4-02	O-ring 14mm	1
3	E4-03	Drain bolt	2
4	E4-04	N/A	1
5	E4-05	Sway bar	1
6	E4-06	N/A	1
7	E4-07	Split Clip	1
8	E4-08	Washer Drain bolt	2
9	E4-09	N/A	1
10	E4-10	Centrifugal gear Parts	1
11	E4-11	N/A	1
12	E4-12	Plain washer 6mm	2
13	E4-13	N/A	2
14	E4-14	N/A	1
15	E4-15	N/A	2
16	E4-16	Oil sensor Assy	1
17	E4-17	Oil seal crankcase(25*41.25*6)	1
18	E4-18	Ball Bearing 6205	1
19	E4-19	Bolt M6 x 14	2
20	E4-20	Nut M10	1

Crankcase Cover

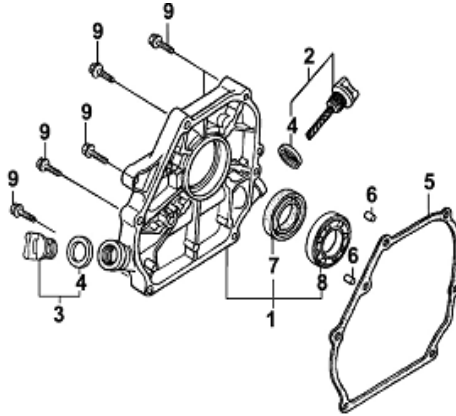

SL-No	KK-No	KK-Name	Qty
1	E5-01	Crankcase cover	1
2	E5-02	Oil Gauge	1
3	E5-03	Oil Plug assembly	1
4	E5-04	seal-oil gauge	2
5	E5-05	Gasket crankcase	1
6	E5-06	Set pin 8X14	2
7	E5-07	Oil Seal 25x41.25x6	1
8	E5-08	Ball Bearing 6205	1
9	E5-09	Bolt M8 x 30	6

Crankshaft Piston

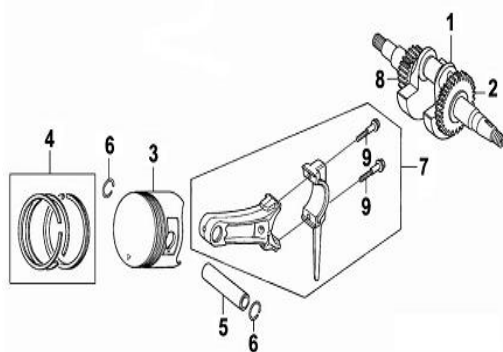

SL-No	KK-No	KK-Name	Qty
1	E6-01	Crankshaft Assy	1
2	E6-02	Governor Gear	1
3	E6-03	Piston	1
4	E6-04	Piston Ring Assy	1
5	E6-05	Piston Pin	1
6	E6-06	Clip Piston Pin	2
7	E6-07	Connecting rod Assy	1
8	E6-08	Timing Gear	1
9	E6-09	Bolt connecting rod M7x35	2

Camshaft

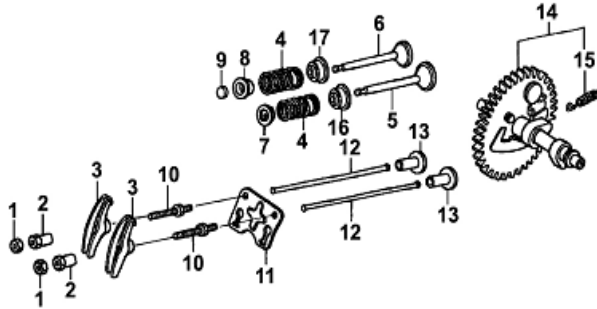

SL-No	KK-No	KK-Name	Qty
	E7-1,2,3,10	Rocker Assy	1
1	E7-01	Buy Rocker Assy	
2	E7-02	Buy Rocker Assy	
3	E7-03	Buy Rocker Assy	
4	E7-04	Valve Spring	2
5	E7-05	Intake Valve	1
6	E7-06	Exhaust Valve	1
7	E7-07	Spring seat Intake Valve	1
8	E7-08	Spring Seat Exhaust Valve	1
9	E7-09	Cap Exhaust Valve	1
10	E7-10	Buy Rocker Assy	2
11	E7-11	Pusher guide	1
12	E7-12	Pusher	2

SL-No	KK-No	KK-Name	Qty
13	E7-13	Tappet	2
14	E7-14	Cam Shaft Assy	1
15	E7-15	N/A	1
16	E7-16	N/A	1
17	E7-17	Inlet valve oil seal	1

Carburetor

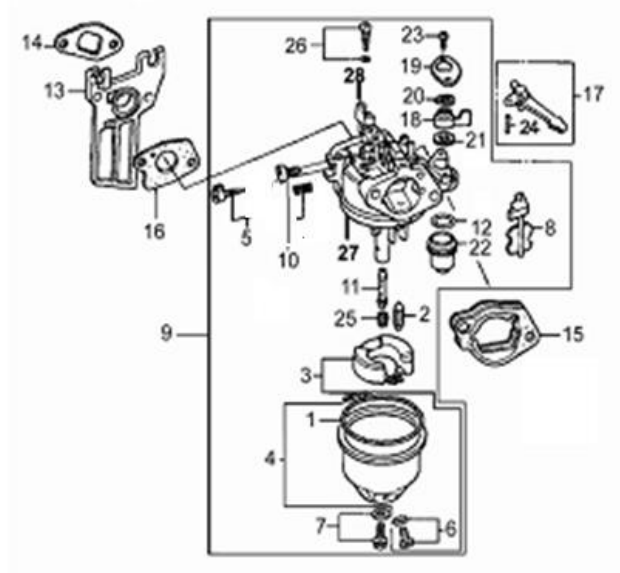

SL-No	KK-No	KK-Name	Qty
1	E8-01	Rubber seal (Fuel cup)	1
2	E8-02	Needle Valve	1

SL-No	KK-No	KK-Name	Qty
3	E8-03	Fuel Floater	1
4	E8-04	Fuel cup	1
5	E8-05	Adjustment screw Idle speed	1
6	E8-06	Screw(Fuel Cup)	1
7	E8-07	Tighten bolt (Fuel cup)	1
8	E8-08	Chock Valve Assy	1
9	E8-09	Carburetor Assy	1
10	E8-10	Adjustment Screw Assy (mixture ratio)	1
11	E8-11	Main Nozzle	1
12	E8-12	O-ring 21x2(Sediment cup)	1
13	E8-13	Block, Carburetor/Insulator	1
14	E8-14	Gasket, inlet port	1
15	E8-15	Steel gasket	1
16	E8-16	Gasket carburetor	1
17	E8-17	Hand grip chock valve assy	1
18	E8-18	Handle Bar Fuel on/off	1
19	E8-19	Upper cover(Fuel on/off)	1
20	E8-20	Spring Washer-(Fuel on/off)	1
21	E8-21	Fuel Valve	1
22	E8-22	Sediment cup	1
23	E8-23	Screw M3x7	2
24	E8-24	N/A	1

SL-No	KK-No	KK-Name	Qty
25	E8-25	Main jet	1
26	E8-26	Measure hole Assy idle speed	1
27	E8-27	N/A	1
28	E8-28	N/A	1

Recoil Starter

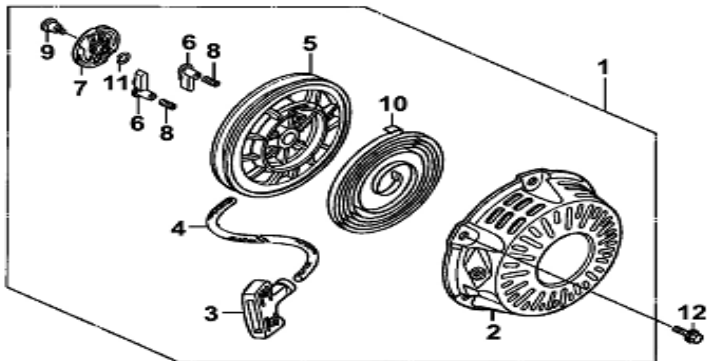

SL-No	KK-No	KK-Name	Qty
1	E9-01	Recoil Starter Assy	1
2	E9-02	Starter cover	1
3	E9-03	Pulling handle	1
4	E9-04	Rope	1
5	E9-05	Roller/Rope Reel	1
6	E9-06	Ratchet	2
7	E9-07	Ratchet guide	1

SL-No	KK-No	KK-Name	Qty
8	E9-08	Ratchet Spring	2
9	E9-09	Pivot Bolt	1
10	E9-10	Starter spring	1
11	E9-11	Friction Spring 16x1	1
12	E9-12	Bolt M6x12 Flanged Hex	3

Fan Cover

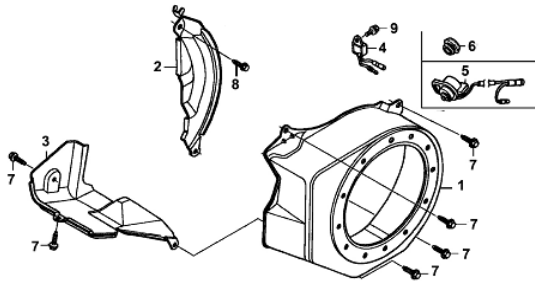

SL-No	KK-No	KK-Name	Qty
1	E10-01	Fan cover	1
2	E10-02	Side Plate	1
3	E10-03	Wind guide	1
4	E10-04	Current Amplifier	1
5	E10-05	Engine switch	1
6	E10-06	N/A	1
7	E10-07	Bolt M6x12 Flanged Hex	6

8	E10-08	Bolt M6 x 20 Flanged Hex	1
---	--------	--------------------------	---

Control

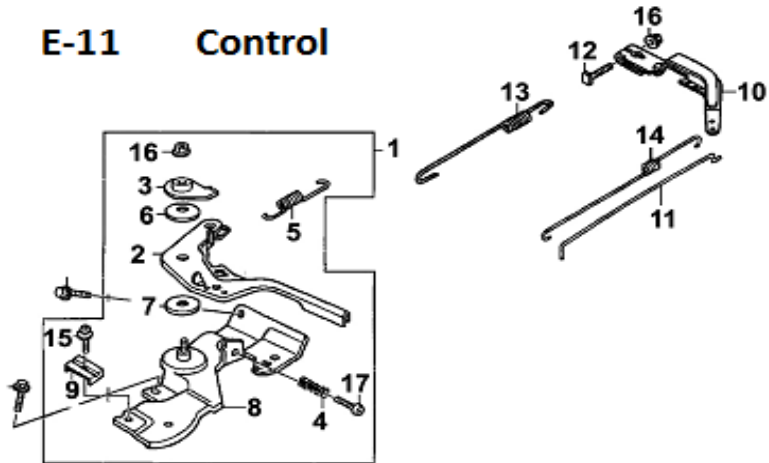

SL-No	KK-No	KK-Name	Qty
1	E11-01	Speed Adjustment Base Ass.	1
2	E11-02	N/A	1
3	E11-03	N/A	1
4	E11-04	Adjustment Spring	1
5	E11-05	Throttle spring	1
6	E11-06	N/A	1
7	E11-07	N/A	2
8	E11-08	N/A	1
9	E11-09	N/A	1
10	E11-10	Speed Adjustment arm	1

SL-No	KK-No	KK-Name	Qty
11	E11-11	Pulling Rod	1
12	E11-12	Quadrante bolt M6x21	1
13	E11-13	Return Spring	1
14	E11-14	Fine Adjustment Spring	1
15	E11-15	N/A	1
16	E11-16	Nut M6 Flanged Nylon	1
17	E11-17	Adjustment Screw	2

Fly Wheel

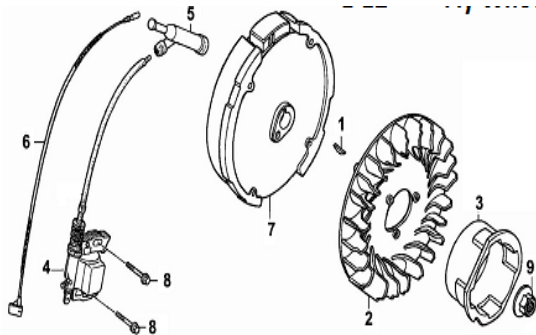

SL-No	KK-No	KK-Name	Qty
1	E12-01	Woodruff key	1
2	E12-02	Fly Wheel Fan	1
3	E12-03	Starter Sleeve	1
4	E12-04	Ignition Coil Assy	1
5	E12-05	Spark Plug Cap	1

SL-No	KK-No	KK-Name	Qty
6	E12-06	Stop lead	1
7	E12-07	Fly Wheel Assy	1
8	E12-08	Bolt 6 x 25	2
9	E12-09	Nut M14 Fly wheel Assy	1

Air Cleaner

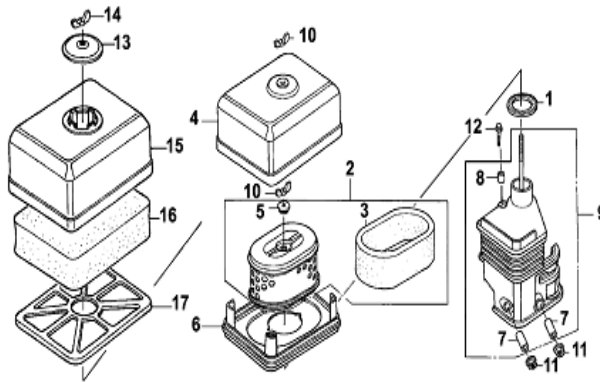

SL-No	KK-No	KK-Name	Qty
	E13	Air Cleaner Assy	1
1	E13-01	Seal Ring 32x47x3	1
2	E13-02	Air Filter Element	1
3	E13-03	N/A	1
4	E13-04	Filter Case	1
5	E13-05	Rubber Fixer	1
6	E13-06	Cover board	1

SL-No	KK-No	KK-Name	Qty
7	E13-07	N/A	2
8	E13-08	N/A	1
9	E13-09	Air Cleaner Seat Assy	1
10	E13-10	Butter Fly nut M6	2
11	E13-11	Nut M6	2
12	E13-12	ST Screw M4 x 12	1
13	E13-13	N/A	1
14	E13-14	N/A	1
15	E13-15	N/A	1
16	E13-16	N/A	1
17	E13-17	N/A	1

Muffler

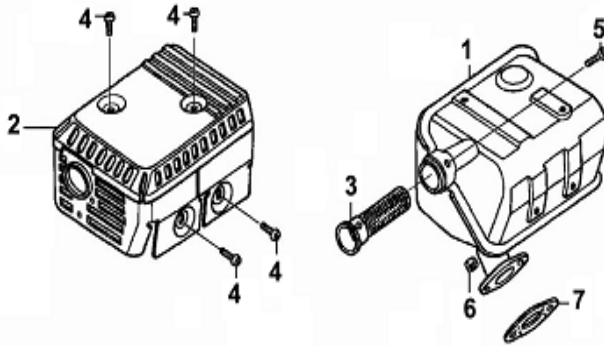

SL-No	KK-No	KK-Name	Qty
1	E14-01	Muffler Assy	1
2	E14-02	N/A	1
3	E14-03	N/A	1
4	E14-04	Screw M5 x 8	4
5	E14-05	N/A	1
6	E14-06	Nut M8	2
7	E14-07	Gasket Muffler	1

Fuel tank

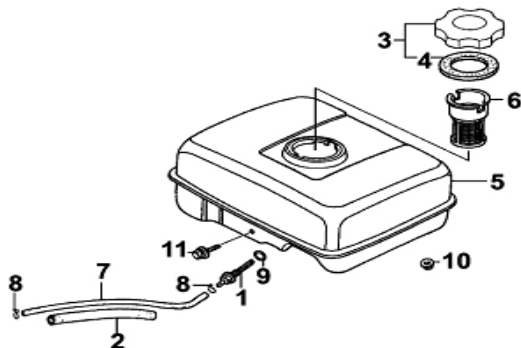

SL-No	KK-No	KK-Name	Qty
1	E15-01	Fuel outlet joint	1
2	E15-02	Sleeve Fuel pipe	1
3	E15-03	Fuel tank cap	1
4	E15-04	Gasket Fuel tank Cap	1
5	E15-05	Fuel tank	1
6	E15-06	Fuel Filter	1
7	E15-07	Fuel Tube M4.5×140	1
8	E15-08	Clip Fuel tube	2
9	E15-09	O-ring 14mm(Fuel outlet joint)	1
10	E15-10	Nut M6 Flanged	2
11	E15-11	Bolt M6x30 Flanged Hex	1

KisanKraft has a large range of products to serve the farmers. A list of our products is given below:

<p>Brush Cutters and Accessories</p> <ul style="list-style-type: none">Brush Cutter/Power WeederBackpack Brush CutterTea PrunerPole pruner with EngineReaper AttachmentBlades-CircularBlades (2 & 3 points)BaffleNylon RopeTap & Go <p>Chainsaws</p> <ul style="list-style-type: none">Petrol ChainsawElectric ChainsawChain Sharpening Machine <p>Engines and Water Pumps</p> <ul style="list-style-type: none">Engine –Diesel-(Horizontal)Engine –Diesel(Vertical)Engine-KeroseneWater Pump with Petrol EngineWater Pump with Kerosene EngineWater Pump with Diesel Engine <p>Hand Tools</p> <ul style="list-style-type: none">SecateursFolding SawGarden RakeGarden ShovelHedge ShearLopperTelescopic Hedge ShearTelescopic Lopping ShearTree PrunerTelescopic Steel Pipe & Fruit Picker BagSheep Shear <p>Garden Tools</p> <ul style="list-style-type: none">Electric Pressure WasherHedge TrimmerLawn Mower (Electric, Petrol & Manual)Leaf Blower	<p>Cultivators and Accessories</p> <ul style="list-style-type: none">Petrol and Diesel <p>Sprayers and Accessories</p> <ul style="list-style-type: none">Battery SprayerPortable Power SprayerTrolley SprayerManual Knapsack SprayerManual Pressure SprayerRose CansHose Crimping MachineHTP SprayerHTP Delivery HoseHTP Hose ReelHTP StandHTP Gun / Lance(Brass Rod)Knapsack Power SprayerMister / Duster / Granuel SpreaderHTP Sprayer Set with Diesel EngineHTP Sprayer Set with Kerosene EngineFogging Machine <p>Milking Machine</p> <ul style="list-style-type: none">Wood ShredderFodder Ensiling Chaff CutterFodder Grinder Chaff CutterFodder Mini Chaff Cutter <p>Harvester</p> <ul style="list-style-type: none">Maize ShellerMaize Sheller + DehuskerMaize Combine HarvesterOnion Digger Carlotti ItalyTea Leaf HarvesterSugarcane Combine HarvesterSugarcane Leaf Stripper <p>Transplanter and Post Hole Digger</p> <ul style="list-style-type: none">Paddy Transplanter (2 & 8 Rows)Transplanter-Vegetable & TobaccoPost Hole Digger(4" to 14" Augers)
---	--



Wide Range of Products for Every Need



For more information give **MISSED CALL: 07676065555**



Many of our products have BIS: ISI certification.



Product	Agricultural Inter-Cultivator	KisanKraft Invoice Date	
Brand	KisanKraft	KisanKraft Invoice No.	
Model	<input type="checkbox"/> KK-IC-208P <input type="checkbox"/> KK-IC-205P		
WARRANTY PERIOD	6 MONTHS	FOR THE SPECIFIED PERIOD FROM THE DATE OF SALE OR DELIVERY WHICHEVER IS EARLIER.	
Dealer's Invoice Date		Dealer's Invoice No.	
Buyer's Info (Name, Address, Phone, etc.):		Dealer's Stamp (Address, Phone, TIN, etc.):	
Buyer's Sign		Dealer's Sign	

Warranty Policy

What is covered: KisanKraft Limited and its manufacturers warrant this product to be free from defects in material or workmanship. All parts defective in material and workmanship are covered. This warranty will only cover defects arising under normal usage.

This warranty is limited to repair or replacement by KisanKraft Limited or its manufacturers of such parts as appear to KisanKraft or its manufacturers, upon inspection, to be defective in material and/or workmanship. KisanKraft or its manufacturers make no warranty with respect to items not manufactured or sold by them. No onsite warranty is provided by KisanKraft Limited or its manufacturers. Defective items must be brought/sent to our Authorized Dealer or KisanKraft Limited's office for service.

What is not covered: The *warranty shall become null and void* and neither KisanKraft Limited nor any of its manufacturers, nor its authorized dealers assumes any responsibility, if the failure was caused by the following:

(1) Operation of product with incorrect fuel or lubricants, (2) Incorrect usage of machine or misuse, (3) Lack of maintenance, (4) Negligence, (5) Accident or physical damage, (6) Repairs made by unauthorized parties and/or with unauthorized parts, (7) Improper set up, adjustments, tampering or altered products (8) Any modification to the product what-so-ever.

Important: (1) Normal maintenance and adjustments to the product is the responsibility of the customer. (2) Normal wear and tear are not covered under warranty. (3) Rubber/plastic parts and consumables such as blades, clutch and clutch-bell, sparkplugs, nylon line, air-filters, fuel-filters, oil seals and gaskets etc. are not covered under the warranty. (4) Electrical Motor, Electrical Parts, Battery Etc. are not covered under the warranty.

Incidental / Consequential Loss: KisanKraft Limited or its manufacturers will not be liable for general damages, including bodily injuries, or for incidental or consequential damages including, but not

limited to, loss of use, loss of profits, loss of production, expense of substitute equipment or other commercial loss or damage.

Limitation of Liability: This limited warranty is in lieu of all other express warranties, obligations, or liabilities. Any implied warranties, obligations or liabilities, including, but not limited to, any implied warranty of merchantability shall be limited in duration to the applicable warranty period. Any action for breach of any warranties hereunder, including, but not limited to, any implied warranty of merchantability must be brought within the applicable warranty period.

Modifications of Warranty: No agent, representative, dealer, or employee of KisanKraft Limited or any of its manufacturers has the authority to increase or alter the obligations of this warranty.

Assignment / Transfer of warranty: The warranty cannot be assigned and shall not transfer if the product is resold by the first buyer. The above warranties are extended to the first end user (original purchaser), and no warranty is made, nor authorized to be made assignable on resale by the first end user.

What you must do to obtain limited warranty service: To obtain performance of any obligation under this warranty for failure during the applicable warranty period, you must deliver the defective product, to the nearest Authorized Dealer, along with proof-of-purchase (invoice/receipt). KisanKraft Limited, its manufacturers and its dealers reserve the right to inspect the claimed defective part(s) to determine if the malfunction is the result of a defect covered by this warranty. Please note that the decision of KisanKraft Limited with respect to any warranty claim is final.

After-sales Service (Including Warranty): KisanKraft Limited does not sell directly to consumers. All sales or supplies are made through Authorized Dealers. It is the responsibility of the Authorized Dealer to provide all after-sales service to consumers. Any warranty claim should be raised by dealer to KisanKraft Limited as per warranty policy.

Jurisdiction: All disputes are subject to Bangalore court's jurisdiction.

Notes:

- This purchase is not contingent upon a product demonstration. The purchaser shall satisfy himself with the product, including any product demonstration or verification of any function, before buying. KisanKraft Limited or its authorized dealers, including online sellers, shall not be liable to give any on-site demonstration after purchase of any of the product.
- Any product once used will not be taken back by KisanKraft Limited.
- Warranty and After Sale Services (including but not limited to installation, Demonstration, Repair, Routine Maintenance etc.), should be done through the Authorized Dealer selling this product.
- Dealers should have their own technician to provide After Sales Services to their Customers. KisanKraft Limited provides free training to Authorized Dealer's technicians at KisanKraft Limited's head office, on request from Authorized Dealer.