

Incidental / Consequential Loss: KisanKraft Limited or its manufacturers will not be liable for general damages, including bodily injuries, or for incidental or consequential damages including, but not limited to, loss of use, loss of profits, loss of production, expense of substitute equipment or other commercial loss or damage.

Limitation of Liability: This limited warranty is in lieu of all other express warranties, obligations, or liabilities. Any implied warranties, obligations or liabilities, including, but not limited to, any implied warranty of merchantability shall be limited in duration to the applicable warranty period. Any action for breach of any warranties hereunder, including, but not limited to, any implied warranty of merchantability must be brought within the applicable warranty period.

Modifications of Warranty: No agent, representative, dealer, or employee of KisanKraft Limited or any of its manufacturers has the authority to increase or alter the obligations of this warranty.

Assignment / Transfer of warranty: The warranty cannot be assigned and shall not transfer if the product is resold by the first buyer. The above warranties are extended to the first end user (original purchaser), and no warranty is made, nor authorized to be made assignable on resale by the first end user.

What you must do to obtain limited warranty service: To obtain performance of any obligation under this warranty for failure during the applicable warranty period, you must deliver the defective product, to the nearest Authorized Dealer, along with proof-of-purchase (invoice/receipt). KisanKraft Limited, its manufacturers and its dealers reserve the right to inspect the claimed defective part(s) to determine if the malfunction is the result of a defect covered by this warranty. Please note that the decision of KisanKraft Limited with respect to any warranty claim is final.

After-sales Service (Including Warranty): KisanKraft Limited does not sell directly to consumers. All sales or supplies are made through Authorized Dealers. It is the responsibility of the Authorized Dealer to provide all after-sales service to consumers. Any warranty claim should be raised by dealer to KisanKraft Limited as per warranty policy.

Jurisdiction: All disputes are subject to Bangalore court's jurisdiction.

Notes:

- This purchase is not contingent upon a product demonstration. The purchaser shall satisfy himself with the product, including any product demonstration or verification of any function, before buying. KisanKraft Limited or its authorized dealers, including online sellers, shall not be liable to give any on-site demonstration after purchase of any of the product.
- Any product once used will not be taken back by KisanKraft Limited.
- Warranty and After Sale Services (including but not limited to installation, Demonstration, Repair, Routine Maintenance etc.), should be done through the Authorized Dealer selling this product.
- Dealers should have their own technician to provide After Sales Services to their Customers. KisanKraft Limited provides free training to Authorized Dealer's technicians at KisanKraft Limited's head office, on request from Authorized Dealer.

This warranty is null & void, if you fail to register the warranty with KisanKraft by sending the KisanKraft Copy with dealer's stamp.

KisanKraft Limited

Product	HEAVY DUTY Petrol Chainsaw	KisanKraft Invoice Date	
Brand	KisanKraft	KisanKraft Invoice No.	
Model	KK-CSP-5720 KK-CSP-8650		
WARRANTY PERIOD	6 MONTHS	FOR THE SPECIFIED PERIOD FROM THE DATE OF SALE OR DELIVERY WHICHEVER IS EARLIER.	
Dealer's Invoice Date		Dealer's Invoice No.	
Buyer's Info (Name, Address, Phone, etc.):		Dealer's Stamp (Address, Phone, TIN, etc.):	
Buyer's Sign		Dealer's Sign	

Warranty Policy

What is covered: KisanKraft Limited and its manufacturers warrant this product to be free from defects in material or workmanship. All parts defective in material and workmanship are covered.

This warranty will only cover defects arising under normal usage.

This warranty is limited to repair or replacement by KisanKraft Limited or its manufacturers of such parts as appear to KisanKraft or its manufacturers, upon inspection, to be defective in material and/or workmanship. KisanKraft or its manufacturers make no warranty with respect to items not manufactured or sold by them. No onsite warranty is provided by KisanKraft Limited or its manufacturers. Defective items must be brought/sent to our Authorized Dealer or KisanKraft Limited's office for service.

What is not covered: The *warranty shall become null and void* and neither KisanKraft Limited nor any of its manufacturers, nor its authorized dealers assumes any responsibility, if the failure was caused by the following:

- (1) Operation of product with incorrect fuel or lubricants, (2) Incorrect usage of machine or misuse, (3) Lack of maintenance, (4) Negligence, (5) Accident or physical damage, (6) Repairs made by unauthorized parties and/or with unauthorized parts, (7) Improper set up, adjustments, tampering or altered products (8) Any modification to the product what-so-ever.

Important: (1) Normal maintenance and adjustments to the product is the responsibility of the customer. (2) Normal wear and tear are not covered under warranty. (3) Rubber/plastic parts and consumables such as blades, clutch and clutch-bell, sparkplugs, nylon line, air-filters, fuel-filters, oil seals and gaskets etc. are not covered under the warranty. (4) Electrical Motor, Electrical Parts, Battery Etc. are not covered under the warranty.

Incidental / Consequential Loss: KisanKraft Limited or its manufacturers will not be liable for general damages, including bodily injuries, or for incidental or consequential damages including, but not limited to, loss of use, loss of profits, loss of production, expense of substitute equipment or other commercial loss or damage.

Limitation of Liability: This limited warranty is in lieu of all other express warranties, obligations, or liabilities. Any implied warranties, obligations or liabilities, including, but not limited to, any implied warranty of merchantability shall be limited in duration to the applicable warranty period. Any action for breach of any warranties hereunder, including, but not limited to, any implied warranty of merchantability must be brought within the applicable warranty period.

Modifications of Warranty: No agent, representative, dealer, or employee of KisanKraft Limited or any of its manufacturers has the authority to increase or alter the obligations of this warranty.

Assignment / Transfer of warranty: The warranty cannot be assigned and shall not transfer if the product is resold by the first buyer. The above warranties are extended to the first end user (original purchaser), and no warranty is made, nor authorized to be made assignable on resale by the first end user.

What you must do to obtain limited warranty service: To obtain performance of any obligation under this warranty for failure during the applicable warranty period, you must deliver the defective product, to the nearest Authorized Dealer, along with proof-of-purchase (invoice/receipt). KisanKraft Limited, its manufacturers and its dealers reserve the right to inspect the claimed defective part(s) to determine if the malfunction is the result of a defect covered by this warranty. Please note that the decision of KisanKraft Limited with respect to any warranty claim is final.

After-sales Service (Including Warranty): KisanKraft Limited does not sell directly to consumers. All sales or supplies are made through Authorized Dealers. It is the responsibility of the Authorized Dealer to provide all after-sales service to consumers. Any warranty claim should be raised by dealer to KisanKraft Limited as per warranty policy.

Jurisdiction: All disputes are subject to Bangalore court's jurisdiction.

Notes:

- This purchase is not contingent upon a product demonstration. The purchaser shall satisfy himself with the product, including any product demonstration or verification of any function, before buying. KisanKraft Limited or its authorized dealers, including online sellers, shall not be liable to give any on-site demonstration after purchase of any of the product.
- Any product once used will not be taken back by KisanKraft Limited.
- Warranty and After Sale Services (including but not limited to installation, Demonstration, Repair, Routine Maintenance etc.), should be done through the Authorized Dealer selling this product.
- Dealers should have their own technician to provide After Sales Services to their Customers. KisanKraft Limited provides free training to Authorized Dealer's technicians at KisanKraft Limited's head office, on request from Authorized Dealer.

Product	HEAVY DUTY Petrol Chainsaw	KisanKraft Invoice Date	
Brand	KisanKraft	KisanKraft Invoice No.	
Model	KK-CSP-5720 KK-CSP-8650		
WARRANTY PERIOD	6 MONTHS	FOR THE SPECIFIED PERIOD FROM THE DATE OF SALE OR DELIVERY WHICHEVER IS EARLIER.	
Dealer's Invoice Date		Dealer's Invoice No.	
Buyer's Info (Name, Address, Phone, etc.):		Dealer's Stamp (Address, Phone, TIN, etc.):	
Buyer's Sign		Dealer's Sign	

Warranty Policy

What is covered: KisanKraft Limited and its manufacturers warrant this product to be free from defects in material or workmanship. All parts defective in material and workmanship are covered.

This warranty will only cover defects arising under normal usage.

This warranty is limited to repair or replacement by KisanKraft Limited or its manufacturers of such parts as appear to KisanKraft or its manufacturers, upon inspection, to be defective in material and/or workmanship. KisanKraft or its manufacturers make no warranty with respect to items not manufactured or sold by them. No onsite warranty is provided by KisanKraft Limited or its manufacturers. Defective items must be brought/sent to our Authorized Dealer or KisanKraft Limited's office for service.

What is not covered: The *warranty shall become null and void* and neither KisanKraft Limited nor any of its manufacturers, nor its authorized dealers assumes any responsibility, if the failure was caused by the following:

- (1) Operation of product with incorrect fuel or lubricants, (2) Incorrect usage of machine or misuse, (3) Lack of maintenance, (4) Negligence, (5) Accident or physical damage, (6) Repairs made by unauthorized parties and/or with unauthorized parts, (7) Improper set up, adjustments, tampering or altered products (8) Any modification to the product what-so-ever.

Important: (1) Normal maintenance and adjustments to the product is the responsibility of the customer. (2) Normal wear and tear are not covered under warranty. (3) Rubber/plastic parts and consumables such as blades, clutch and clutch-bell, sparkplugs, nylon line, air-filters, fuel-filters, oil seals and gaskets etc. are not covered under the warranty. (4) Electrical Motor, Electrical Parts, Battery Etc. are not covered under the warranty.

This warranty is null & void, if you fail to register the warranty with KisanKraft by sending the KisanKraft Copy with dealer's stamp.

KisanKraft Limited

Wide Range of Products for Every Need



For more information give **MISSED CALL: 07676065555**



Many of our products have BIS: ISI certification.



User Manual



KisanKraft Limited

Sri Huchhanna Tower, #4, 1st Main, 7-A Cross, Maruthi Layout, Dasarahalli,
HAF Post, Hebbal, Bangalore 560024, Karnataka, INDIA

- ◆ Bangalore (HO) ◆ Ahmedabad ◆ Bhopal ◆ Coimbatore
- ◆ Guwahati ◆ Hyderabad ◆ Nellore
- ◆ Jaipur ◆ Karnal ◆ Kolkata ◆ Lucknow ◆ Pune ◆ Raipur ◆

KisanKraft has a large range of products to serve the farmers. A list of our products is given below:

<p>Brush Cutters and Accessories</p> <ul style="list-style-type: none"> Brush Cutter/Power Weeder Backpack Brush Cutter Tea Pruner Pole pruner with Engine Reaper Attachment Blades-Circular Blades (2 & 3 points) Baffle Nylon Rope Tap & Go <p>Chainsaws</p> <ul style="list-style-type: none"> Petrol Chainsaw Electric Chainsaw Chain Sharpening Machine <p>Engines and Water Pumps</p> <ul style="list-style-type: none"> Engine –Diesel-(Horizontal) Engine –Diesel(Vertical) Engine-Kerosene Water Pump with Petrol Engine Water Pump with Kerosene Engine Water Pump with Diesel Engine <p>Hand Tools</p> <ul style="list-style-type: none"> Secateurs Folding Saw Garden Rake Garden Shovel Hedge Shear Lopper Telescopic Hedge Shear Telescopic Lopping Shear Tree Pruner Telescopic Steel Pipe & Fruit Picker Bag Sheep Shear <p>Garden Tools</p> <ul style="list-style-type: none"> Electric Pressure Washer Hedge Trimmer Lawn Mower (Electric, Petrol & Manual) Leaf Blower 	<p>Cultivators and Accessories</p> <ul style="list-style-type: none"> Petrol and Diesel <p>Sprayers and Accessories</p> <ul style="list-style-type: none"> Battery Sprayer Portable Power Sprayer Trolley Sprayer Manual Knapsack Sprayer Manual Pressure Sprayer Rose Cans Hose Crimping Machine HTP Sprayer HTP Delivery Hose HTP Hose Reel HTP Stand HTP Gun / Lance(Brass Rod) Knapsack Power Sprayer Mister / Duster / Granuel Spreader HTP Sprayer Set with Diesel Engine HTP Sprayer Set with Kerosene Engine Fogging Machine <p>Milking Machine</p> <ul style="list-style-type: none"> Wood Shredder Fodder Ensiling Chaff Cutter Fodder Grinder Chaff Cutter Fodder Mini Chaff Cutter <p>Harvester</p> <ul style="list-style-type: none"> Maize Sheller Maize Sheller + Dehusker Maize Combine Harvester Onion Digger Carlotti Italy Tea Leaf Harvester Sugarcane Combine Harvester Sugarcane Leaf Stripper <p>Transplanter and Post Hole Digger</p> <ul style="list-style-type: none"> Paddy Transplanter (2 & 8 Rows) Transplanter-Vegetable & Tobacco Post Hole Digger(4" to 14" Augers)
--	---

KK-No	KK-Name	Qty	KK-No	KK-Name	Qty
E-26	Ball Bearing 6202	2	E-59	Bolt Allen M5x16 W/P/S Washer	3
E-27	Oil-Seal 15x28x7	1	E-60	Bolt Allen M6x25	2
E-28	Crank Case(Left)	1	E-61	Bolt Allen M4x8	8
E-29	Crank Case(Right)	1	E-62	Bolt Allen M5x25	4
E-30	Oil-Seal 15x28x5	1	E-63	Bolt Allen M5x8 W/P/S Washer	2
E-31	Pin 8x10	2	E-65	Bar Bolt	2
E-32	Guide Plate	1	E-66	Bolt Allen M4x6	1
E-33	Nut Hex Flanged M8	2	E-67	Bolt Allen M5x35	6
E-34	Gasket Insulator	2	E-68	Bolt Star M5x10	1
E-35	Insulator Spacer	1	E-69	Bolt Allen M4x10	3
E-36	Insulator	1	E-70	Bolt Allen M4x16	2
E-37	Gasket Carburetor	1	E-71	Bolt Allen M5x18 W/P/S Washer	2
E-38	Carburetor	1	E-72	Gasket Crankcase	1
E-39	Air Intake Tube	1	E-73	Ventilate Mouth	1
E-40	Air Cleaner Inside Cover	1	E-74	Bolts For T-Slot M5 x 50	2
E-41	Air Cleaner	1	E-74-1	Bush For Bolt T-Slot	1
E-42	Gasket Heat Insulation	2	E-75	Nut Hex Flanged M5	2
E-43	Clutch Shoe Assy	1			

CONTENTS

BEFORE GETTING STARTED8

SAFETY SYMBOLS8

SAFETY PRECAUTIONS.....10

PARTS OVERVIEW15

INSTALLING GUIDE BAR AND SAW CHAIN16

FUEL AND CHAIN OIL.....17

STARTING AND STOPPING.....20

SAWING21

MAINTENANCE.....24

TROUBLESHOOTING28

TECHNICAL SPECIFICATIONS.....31

PARTS DIAGRAM & LIST- BODY32

2 - STROKE PETROL ENGINE- MANUAL35

PARTS DIAGRAM & LIST- ENGINE46

Product	HEAVY DUTY Petrol Chainsaw	KisanKraft Invoice Date	
Brand	KisanKraft	KisanKraft Invoice No.	
Model	KK-CSP-5720 KK-CSP-8650		
WARRANTY PERIOD	6 MONTHS	FOR THE SPECIFIED PERIOD FROM THE DATE OF SALE OR DELIVERY WHICHEVER IS EARLIER.	
Dealer's Invoice Date		Dealer's Invoice No.	
Buyer's Info (Name, Address, Phone, etc.):		Dealer's Stamp (Address, Phone, TIN, etc.):	
Buyer's Sign		Dealer's Sign	

Warranty Policy

What is covered: KisanKraft Limited and its manufacturers warrant this product to be free from defects in material or workmanship. All parts defective in material and workmanship are covered. This warranty will only cover defects arising under normal usage. This warranty is limited to repair or replacement by KisanKraft Limited or its manufacturers of such parts as appear to KisanKraft or its manufacturers, upon inspection, to be defective in material and/or workmanship. KisanKraft or its manufacturers make no warranty with respect to items not manufactured or sold by them. No onsite warranty is provided by KisanKraft Limited or its manufacturers. Defective items must be brought/sent to our Authorized Dealer or KisanKraft Limited's office for service.

What is not covered: The warranty shall become null and void and neither KisanKraft Limited nor any of its manufacturers, nor its authorized dealers assumes any responsibility, if the failure was caused by the following:

- (1) Operation of product with incorrect fuel or lubricants, (2) Incorrect usage of machine or misuse, (3) Lack of maintenance, (4) Negligence, (5) Accident or physical damage, (6) Repairs made by unauthorized parties and/or with unauthorized parts, (7) Improper set up, adjustments, tampering or altered products (8) Any modification to the product what-so-ever.

Important: (1) Normal maintenance and adjustments to the product is the responsibility of the customer. (2) Normal wear and tear are not covered under warranty. (3) Rubber/plastic parts and consumables such as blades, clutch and clutch-bell, sparkplugs, nylon line, air-filters, fuel-filters, oil seals and gaskets etc. are not covered under the warranty. (4) Electrical Motor, Electrical Parts, Battery Etc. are not covered under the warranty.

This warranty is null & void, if you fail to register the warranty with KisanKraft by sending the KisanKraft Copy with dealer's stamp.

KisanKraft Limited

KK-No	KK-Name	Qty	KK-No	KK-Name	Qty
E-1	Upper Cover	1	E-43-1	N/A	
E-2	Air Filter Cover	1	E-43-2	Retainer	1
E-3	Air Filter Cover Lock	1	E-43-3	Spring-Clutch	1
E-4	Summer and winter switching device	1	E-44	Clutch Adjusting Washer	1
E-5	Pin B3*22	1	E-45	Clutch Drum	1
E-5-1	Spring(Air Filter Cover Lock)	1	E-46	Needle Bearing (Clutch Drum)	1
E-6	Choker Pull rod	1	E-47	Oil Pump Worm Gear	1
E-7	Choker Plug	1	E-48	Oil Pump Cover	1
E-8	Choker Handle	1	E-49	Pipe oil outlet	1
E-9	Switch On/Off	1	E-50	Oil Pump	1
E-10	Cylinder	1	E-51	Pipe oil inlet	1
E-11	Cylinder Lid(Left)	1	E-51-1	Clip fuel Tube	2
E-12	Gasket Cylinder Lid	2	E-52	Oil Filter	1
E-13	Cylinder Lid(Right)	1	E-53	Ignition Coil	1
E-14	Spark Plug	1	E-53-1	Grommet(Ignition Coil)	1
E-15	Gasket Muffler	1	E-53-2	Spring (Spark Plug)	1
E-16	Muffler	1	E-53-3	Cap(Spark Plug)	1
E-17	Piston Pin	1	E-53-4	Dust Cap (Spark Plug)	1
E-18	Gasket Cylinder	2	E-54	Cord Comp-Coil	1
E-19	Bolt Allen M5x20	1	E-55	Fly Wheel Assembly	1
E-20	Piston Ring	2	E-55-1	Claw Spring	2
E-21	Piston	1	E-55-2	Start Claw	2
E-22	Cir clip Piston Pin	2	E-55-3	Screw(Start Claw)	2
E-23	Needle Bearing Piston Pin	1	E-56	Nut M8X1-Flanged Hex	1
E-24	Crank Shaft Assy	1	E-57	Primer Bulb	1
E-25	Key -Crankshaft	1	E-58	Stand(Primer Bulb)	1

PARTS DIAGRAM & LIST- ENGINE

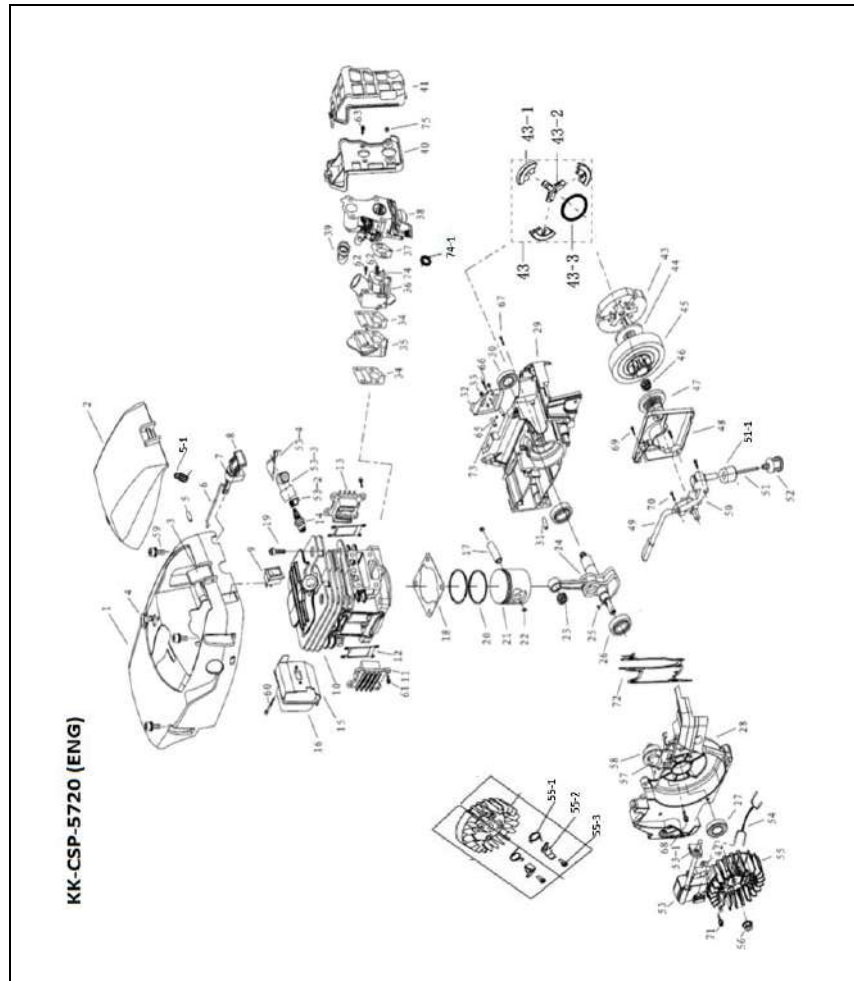

Incidental / Consequential Loss: KisanKraft Limited or its manufacturers will not be liable for general damages, including bodily injuries, or for incidental or consequential damages including, but not limited to, loss of use, loss of profits, loss of production, expense of substitute equipment or other commercial loss or damage.

Limitation of Liability: This limited warranty is in lieu of all other express warranties, obligations, or liabilities. Any implied warranties, obligations or liabilities, including, but not limited to, any implied warranty of merchantability shall be limited in duration to the applicable warranty period. Any action for breach of any warranties hereunder, including, but not limited to, any implied warranty of merchantability must be brought within the applicable warranty period.

Modifications of Warranty: No agent, representative, dealer, or employee of KisanKraft Limited or any of its manufacturers has the authority to increase or alter the obligations of this warranty.

Assignment / Transfer of warranty: The warranty cannot be assigned and shall not transfer if the product is resold by the first buyer. The above warranties are extended to the first end user (original purchaser), and no warranty is made, nor authorized to be made assignable on resale by the first end user.

What you must do to obtain limited warranty service: To obtain performance of any obligation under this warranty for failure during the applicable warranty period, you must deliver the defective product, to the nearest Authorized Dealer, along with proof-of-purchase (invoice/receipt). KisanKraft Limited, its manufacturers and its dealers reserve the right to inspect the claimed defective part(s) to determine if the malfunction is the result of a defect covered by this warranty. Please note that the decision of KisanKraft Limited with respect to any warranty claim is final.

After-sales Service (Including Warranty): KisanKraft Limited does not sell directly to consumers. All sales or supplies are made through Authorized Dealers. It is the responsibility of the Authorized Dealer to provide all after-sales service to consumers. Any warranty claim should be raised by dealer to KisanKraft Limited as per warranty policy.

Jurisdiction: All disputes are subject to Bangalore court’s jurisdiction.

Notes:

- This purchase is not contingent upon a product demonstration. The purchaser shall satisfy himself with the product, including any product demonstration or verification of any function, before buying. KisanKraft Limited or its authorized dealers, including online sellers, shall not be liable to give any on-site demonstration after purchase of any of the product.
- Any product once used will not be taken back by KisanKraft Limited.
- Warranty and After Sale Services (including but not limited to installation, Demonstration, Repair, Routine Maintenance etc.), should be done through the Authorized Dealer selling this product.
- Dealers should have their own technician to provide After Sales Services to their Customers. KisanKraft Limited provides free training to Authorized Dealer’s technicians at KisanKraft Limited’s head office, on request from Authorized Dealer.

This warranty is null & void, if you fail to register the warranty with KisanKraft by sending the KisanKraft Copy with dealer’s stamp.

KisanKraft Limited

BEFORE GETTING STARTED

We wish to thank you for choosing our product. We are confident that the high quality of our product will meet your requirement and will give you long-lasting service. In order to avoid accidents or injury, please read this manual carefully before using the machine. After reading, preserve this manual for further reference.

SAFETY SYMBOLS

Types of Warning Used In the Manual:

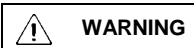

WARNING

This mark indicates instructions which must be followed in order to prevent accidents which could lead to serious bodily injury or death.



IMPORTANT

This mark indicates instructions which must be followed, or it leads to mechanical failure, breakdown, or damage.

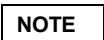

NOTE

This mark indicates hints or directions useful in the use of the product.

Explanation of Symbols and Safety Warnings:

Read operation manual before using this machine	
Wear head, eye and ear protection.	
Warning! Kickback is danger.	
Warning / Attention	

Using a piece of wire, or the likes, pull out the fuel filter and wash with clean white kerosene. When it is fouled heavily, replace the filter and also wash the tank inside.

⚠ Use of fire is strictly prohibited



Carbon removal

Remove carbon from the muffler in-/outlet, cylinder and piston. This work requires engine servicing skill and some tools. Consult the dealer or nearest service center.

⚠ CAUTIONS DURING INSPECTION

- Disconnect the ignition plug wires before inspection or adjustment to prevent unexpected start of engine.
- Do not touch the engine immediately after operation to prevent burn.
- Use of fire is strictly prohibited when handling the fuel (petrol).
- Make sure to clean spilled fuel sufficiently before using the engine.
- Do not wash the engine with water.
- Do not change the setting revolution speed carelessly. (Consult your dealer when changing the revolution speed.)

STORAGE

When releasing the engine from operation for more than 30 days, it must be serviced and stored as follows with care to prevent the starting trouble or malfunction due to degeneration of fuel.

1. Drain the fuel from the fuel tank and start to run the engine till it is stopped due to use-up of fuel.
2. Wash the inside of fuel tank and fuel filter with white kerosene.
⚠ Use of fire is strictly prohibited
3. Removing the ignition plug, inject a small quantity of new engine oil through the plughole. After idling slowly for few revolutions operating the recoil starter, install the ignition plug. Pull the recoil starter again and stop it at the position where it is felt heavy.
4. Clean the external surfaces with soft cloth and store it at a dry place free from fires.

NOTE: If the unit is left over without draining fuel, impurities in the fuel could clog the fuel passages such as the carburetor, fuel filter, or others, and cause engine troubles. Make sure to drain the fuel when storing the unit for a long period of time.

⚠ Sufficient care must be taken not to use fires at the vicinity when handling the fuel.

Inspection, cleaning of ignition plug		✓		
Inspection, cleaning of fuel filter		✓		
Removal of carbon from muffler, cylinder		✓		
Cleaning of spark arrestor		✓		
Replacement of ignition plug			✓	
Replacement of fuel piping (fuel pipe and grommet)				✓

INSPECTION AND SERVICE BEFORE EACH OPERATION

Cleaning of air cleaner

Wash the element with white kerosene and then immerse it in engine oil. Squeeze it tightly with single hand.

 **Use of fire is strictly prohibited**



Cleaning and service at respective sections

- Clean thoroughly around the muffler.
- Clean the cooling fins and the cooling air inlet.
- Inspect and retighten bolts and nuts.
- Inspect the fuel leakage.



INSPECTION AND SERVICE AT EVERY 50-HOUR

Cleaning and adjustment of ignition plug

After removing carbon accumulated on the electrodes and the insulator, adjust the clearance between the electrodes at 0.6 ~ 0.7 mm

 When mounting the plug cap, push it in securely

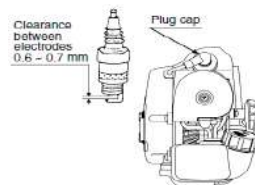







Cleaning of fuel filter

IMPORTANT

If warning seals peel off or become soiled and is impossible to read, you should contact the dealer from which you purchased the product to order new seals and affix the new seal(s) in the required location(s).

Symbols on the Machine:

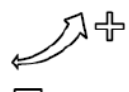
For safe operation and maintenance, symbols are carved on the machine. Follow these indications and please be careful not to make any mistake.

The port to refuel the " MIX PETROL "	
The port to refuel the "CHAIN OIL "	
The indication regarding the choke. Pulling out the choke knob, the choke closes.	
The indication regarding the switch. Flipping the engine switch to the "O" (OFF) direction, the engine stops.	
The indication regarding the chain oil adjuster nut. " - " direction-the oil flow decrease " + " direction-the oil flow increase.	
H: The High-speed adjustment screw. L: The Slow-speed adjustment screw.	

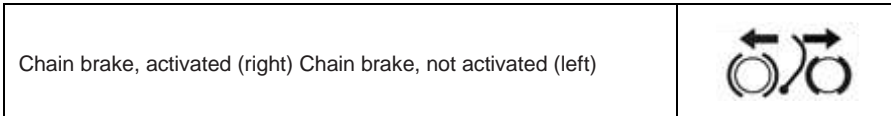

SAFETY PRECAUTIONS

Before Using the Machine:

- a) Read this operation manual carefully to understand how to operate this properly
- b) You should never use the product when under the influence of alcohol, when suffering from exhaustion or lack of sleep, when suffering from drowsiness as a result of having taken cold medicine. or at any other time when a possibility exists that your judgment be might be impaired or that you might not be able to operate the machine properly and in a safe manner
- c) Avoid running the engine indoors. The exhaust gases contain harmful carbon monoxide.
- d) Never use the product under circumstances like those described below:
 1. When the ground is slippery or when other conditions exist which might make it not possible to maintain a steady posture.
 2. At night, at times of heavy fog, or at any other times when your field of vision might be limited and it would be difficult to gain a clear view of the area.
 3. During rainstorms, during lightning storms, at times of strong or gale-force winds, or at any other times weather conditions might make it unsafe to use this product.
- e) When using this product for the first time, before beginning actual work learn to handle it from a skilled worker.
- f) Lack of sleep, tiredness, or physical exhaustion results in lower attention spans, and this in turn leads to accidents and injury.
- g) Limit the amount of time of using the machine continuously to somewhere around 10 minutes per session, and take 10-20minutes of rest between work sessions. Also try to keep the total amount of work performed in a single day under 2 hours or less.
- h) Be sure to keep this manual handy so that you may refer to it later whenever any questions arise.
- i) Always be sure to include this manual when selling, lending, or otherwise transferring the ownership of the product.
- j) Never allow children or anyone unable to fully understand the directions given in this manual to use this product.



- Do not operate the engine while withered grasses, leaves or other inflammable substances are sticking in or around the muffler cover.
- Do not touch the ignition plug cap or high-voltage cord during operation. (There is risk of electric shock or physical injury.)
- Do not operate the engine with the muffler or air cleaner cover removed

ADJUSTING THE CARBURETOR

- ⚠ Engine revolution speed is adjusted at the optimum condition before shipping from the factory. It should be adjusted only when it fails to operate properly. (Consult your dealer when adjustment is necessary.)
 1. Use the slow speed adjusting screw to adjust the slow speed revolutions.
 - Right turns: Increase the revolution speed.
 - Left turns: Slow down the revolution speed.
 - ⚠ Increasing the slow revolution excessively causes the driven equipment unable to stop even if the throttle lever is returned. The revolution speed should not be increased excessively.
 2. In case with the slow speed fuel adjusting screw Normal position is where it is returned by one turn from the fully closed position (right turn).
 - Right turns: Increase the thickness of fuel.
 - Left turns: Decrease the thickness of fuel.
 3. In case with the high speed fuel adjustment screw
 - Right turns: Decrease the thickness of fuel.
 - Left turns: Increase the thickness of fuel.
 - ⚠ Fuel adjustment for the carburetor is completed at the optimum condition before shipping from the factory. When it is necessary to adjust, consult your dealer.
 - ⚠ Do not decrease the thickness of fuel too much. (It could result in the seizure trouble of engine.)

INSPECTION AND SERVICE

Table of regular inspections

Item \ Time	Before Each Operation	At Every 50-hours	At Every 100-hours	2 Years
Inspection and retightening of bolts, nuts	✓			
Inspection of fuel leakage	✓			
Inspection, cleaning of air cleaner	✓			
Cleaning at cooling air inlet, cooling fin and around muffler	✓			

- When there is no subsequent work, drain the fuel from the fuel tank and restart the engine to use up the fuel remaining in the carburetor.

CAUTION

- Place the engine at a horizontal position when the driven equipment is not used at the rest time, or others, in summer season. (If the tank is tilted as much as the inside of fuel cap is submerged in the fuel, the fuel may leak.)
- Do not touch the engine body, especially the muffler, during or immediately after stopping the operation. (There is risk of burn.)

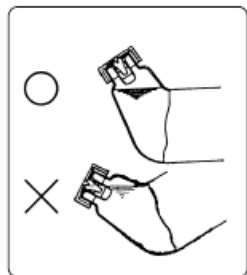

PRECAUTIONS DURING OPERATION

- After starting the engine, set the throttle lever at the slow speed position and warm up the engine for approx. 2~3 minute. As the engine worms up, the engine will be accelerated smoothly.
- Do not attempt to raise the engine speed abruptly immediately after the start because the lubrication oil may not be distributed yet all over the engine.
- If the throttle lever is turned to the fully opened position, the revolution speed picks up to a considerably higher level, which could not only shorten the life of engine but also cause trouble. It should be avoided to race the engine at high speed under no load condition or raise the speed unnecessarily.
- Before starting operation, make sure to inspect the engine in accordance with the "Inspection before starting the engine".
- Do not operate the engine at the indoor or a place with poor ventilation. (Exhaust gas contains odorless and harmful carbon monoxide.)
- Do not insert in or approach hands or foot at the moving or rotating sections.
- Stop the engine immediately if it has been discovered any leakage of fuel or gas from the carburetor, muffler, fuel tank, crankcase, cylinder or mating face at respective sections. (Contact a dealer or service center for repair.)
- Do not change the setting revolution speed of engine unnecessarily.
- Be careful not to touch highly heated muffler or sections on the engine to avoid possible risk of burn.

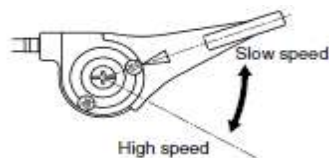

as follows.

- Helmet
- Protection goggles or face Protector
- Thick work gloves
- Non-slip-sole work boots
- Ear protectors



- And you should carry with you the below given things:
 - Attached tools and files.
 - Properly reserved fuel and chain oil.
 - Things to notify your working area (Rope, warning signs)
 - Whistle (for collaboration or emergency)
 - Hatchet or saw (for removal of obstacles)
- Never use the product when wearing pants with loose cuffs, when wearing sandals, or when barefoot.

Warning Considering Handling of Fuel:

- The engine of this product is designed to run on a mixed fuel which contains highly flammable petrol. Never store cans of fuel or refill the fuel tank in any place where there is a boiler stove, wood fire, electrical sparks, welding sparks, or any other source of heat or fire which might ignite the fuel.
- Smoking while operating the product or refilling its fuel tank is extremely dangerous. Always be sure to keep lit cigarettes away from the product at all times.
- When refilling the tank always turn off the engine first and take a careful look round to make sure that there are no sparks or open flames anywhere nearby before refueling.
- If any fuel spillage occurs during refueling, use a dry rag to wipe up spills before turning the engine back on again.
- After refueling, screw the fuel cap back tightly onto the fuel tank and then carry the product to a spot 3m or more away from where it was refueled before turning on the engine.



Before Starting Engine:

- Check working place, the cutting object and cutting direction. If there is obstacle, remove it.
- Never start cutting until you have a clear work area, secure footing and a planned retreat path from the falling tree.

- c) Use caution and keep bystanders and animals out of the working area whose diameter is 2.5 times of the cutting object.
- d) Inspect the machine for worn, loose, or damaged parts. Never operate the machine that is damaged, improperly adjusted, or is not completely and securely assembled. Make sure that the saw chain stops moving when the throttle control trigger is released.

When Starting the Engine:

- a) Always hold the machine firmly with both hands when the engine is running. Use a firm grip with thumb and fingers encircling the handles.
- b) Keep all parts of your body from the machine when the engine is running.
- c) Before starting the engine, make sure the saw chain is not contacting anything.

Operation:

- a) Keep the handle dry, clean and free of oil or fuel mixture.
- b) Never touch the muffler, spark plug or other metallic parts of the engine while the engine is in operation or immediately after stopping the engine. Doing so could result in serious burns or electrical shock.
- c) Use extreme caution when cutting small size brush and saplings because slender material may catch the saw chain and be whipped toward your off balance.
- d) When cutting a limb that is under tension in the wood fibers is released.
- e) Check the tree for dead branches that could fall during the felling operation.
- f) Always shut the engine off, before setting it down.

Kickback Safety Precautions for Chain Saw Users



WARNING

Take care when using your saw and make sure the kickback zone of the bar never touches any object.



1. Kickback may occur when the nose or tip of the guide bar touches an object, or when the wood closes may cause a lightning fast reverse reaction, kicking the guide bar up and back towards the operator. Pinching the saw chain along the top of the guide bar may push the guide bar rapidly back towards the operator. Either of these reactions may cause you to lose control of the saw which could result in serious personal injury.
2. Do not rely exclusively on the safety devices built into your saw. As a chain saw user you should take several steps to keep cutting jobs free from accident or injury.
 - With a basic understanding of kickback you can reduce or eliminate the element of surprise. Sudden surprise contributes to accidents.
 - Keep a good grip on the saw with both hands. The right hand on the rear handle, and the left hand on the front handle, when the engine is running. Use a firm grip

- 6. If you move the throttle lever to the high-speed side a little after the engine has started, the starter lever returns to the operating position. Continue the warm-up operation for 2 to 3 minutes in this condition. Observing the condition of the engine, move the throttle lever to a desired engine speed.

START

⚠ CAUTION

- Before starting the engine, confirm that the area of radius 15 m around the engine is completely evacuated.
- Do not operate the engine when any flammable material (gasoline, volatile chemicals, or others) is present around it.
- Driven equipment may start simultaneously with the start of engine. Carefully read the instruction manual of the equipment and start the engine carefully.
- When a class FC oil is used, a larger resistance may be felt when pulling the recoil starter grip under low temperature condition or at the initial operation at the next season. This is related to the characteristic of the oil and there is no problem on the engine. Once started, it will return to the normal condition.

Concerning New Start System

It can start even if it is pulled slower than normal.

- If the rope is pulled (vigorously) till it will not come out any more, it could damage the recoil mechanism.
- Do not disassemble the recoil. It is dangerous to disassemble the inside of recoil. (Consult your dealer when it is necessary to replace related parts.)
- If the decompression slot of cylinder is clogged, the engine may start slower than normal. Clean the slot to restore the normal condition.

STOP

1. Set the throttle lever at the slow speed position.

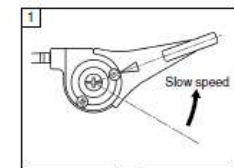

2. Turn the engine switch to the "OFF" position. (Switch position may vary depending on the specifications. Refer to the instruction manual of driven equipment.) In case of a push button type switch, keep pressing the push button till the engine stops completely.
 - Replenish the fuel before using up completely. It will make easier at the next starting.

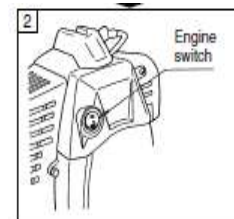

START (STARTER LEVER TYPE UNIT)

1. Turn the engine switch to the "ON" side.

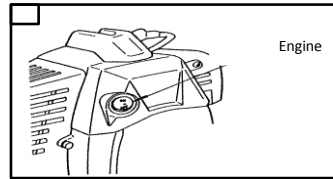

2. Set the throttle lever at the slowest speed position.

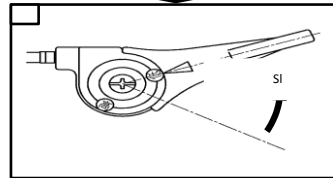

3. Push the priming button repeatedly with finger till it hits the top. (More than 10 times)
Pressing the priming button is necessary to prime the fuel to facilitate the start-up. Since any excess amount of primed fuel returns to the tank, there is no problem of over-priming. Prime the fuel rather more than sufficiently to avoid starting trouble.

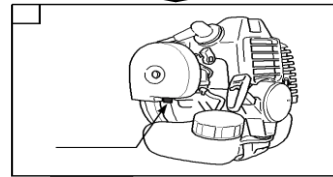

4. Turn down the starter lever of carburetor to set it at the start position.
It is not necessary to operate the starter lever when the engine is warmed up (For about 15 minutes after stopping the engine.)
(To be left in the operating position)
Depending on specifications, the starter lever may be provided at the throttle wire side.

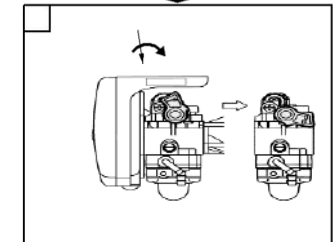

5. While holding down the engine firmly, grasp the recoil starter grip and pull vigorously

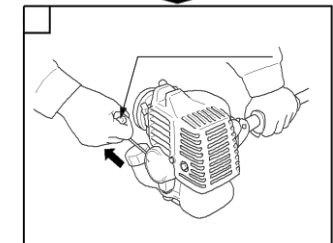

CAUTION:

- a) When the engine stops on the way after starting, or
- b) When the engine fails to start after trying the recoil operation for 7 to 8 times.

Return the starter lever to the operating position and try the recoil operation.

with thumbs and fingers encircling the chain saw handles. A firm grip will help you reduce kickback and maintain control of the saw.

- Make certain that the area in which you are cutting is free from obstructions Do not let the nose of the guide bar contact a log, branch, or any other obstruction which could be hit while you are operating the saw.
- Cut at high engine speeds.
- Do not overreach or cut above shoulder height.
- Follow manufactures sharpening and maintenance instructions for saw chain.
- Only use replacement bars and chains specified by the manufacturer or the equivalent.

Chain Brake and Front Hand Guard

Your chain saw is equipped with a chain brake that is designed to stop the chain if you get a kickback. The chain brake reduces the risk of accidents, but only you can prevent them.

- The chain brake (A) can either be activated manually (by your left hand) or automatically by the inertia release mechanism.
- The brake is applied when the front hand guard (B) is pushed forwards.
- To release the chain brake pull the front hand guard backwards, towards the front handle.
- In the felling position the left hand is in a position that makes manual activation of the chain brake impossible. With this type of grip, that is when the left hand is placed so that it cannot affect the movement of the front hand guard, the chain brake can only be activated by the inertia action.

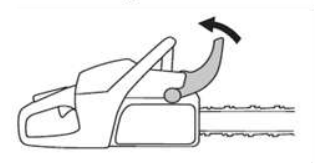
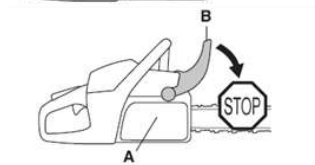
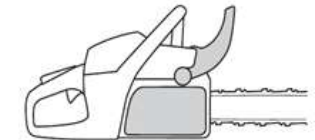

- The way the chain brake is activated, either manually or automatically by the inertia release mechanism, depends on the force of the kickback and the position of the chain saw in relation to the object that the kickback zone of the bar strikes. If you get a violent kickback while the kickback zone of the bar is farthest away from you the chain brake is designed to be activated by the inertia in the kickback direction.
- If the kickback is less violent or the kickback zone of the bar is closer to you the chain brake is designed to be activated manually by the movement of your left hand.



Chain Catcher:

The chain catcher is designed to catch the chain if it snaps or jumps off. This should not happen if the chain is properly tensioned and if the bar and chain are properly serviced and maintained

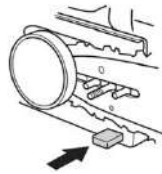

Maintenance:

- In order to maintain your product in proper working order, perform the maintenance and checking operations described in the manual at regular intervals.
- Always be sure to turn off the engine before performing any maintenance or checking procedures.

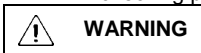

The metallic parts reach high temperatures immediately after stopping the engine.



- Leave all maintenance other than the items listed in the Owner's Manual to your competent servicing dealer.

Transport:



- For longer periods of transport of the chain saw, the fuel and chain oil tanks should be emptied.
- The guide bar cover must always be fitted to the cutting attachment when the machine is being transported or in storage, in order to prevent accident contact with

METHODS OF STARTING & STOPPING THE ENGINE

START (CHOKE TYPE UNIT):

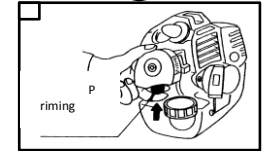
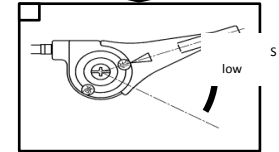
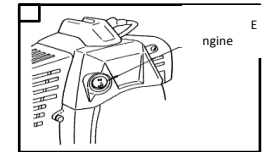
- Turn the engine switch to the "ON" side.
- Set the throttle lever at the slow speed position.
- Push the priming button repeatedly with finger till it hits the top. (More than 10 times) Pressing the priming button is necessary to prime the fuel to facilitate the start-up. Since any excess amount of primed fuel returns to the tank, there is no problem of over-priming. Prime the fuel rather more than sufficiently to avoid starting trouble.



- Turn the choke lever to the fully closed position (at the  Mark).
When sufficient fuel is retained and the engine is warm, set the choke lever at the fully opened position (at the  mark)

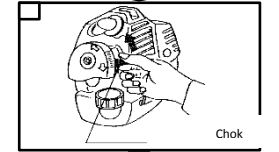

- While holding down the engine firmly, grasp the recoil starter grip and pull vigorously

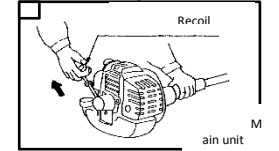

- When the engine has started, return the choke lever gradually to the fully opened position (at the  Mark).
If only exploding sounds are heard, but it does not start, return the choke lever to the fully closed position and pull the starter grip vigorously once again.

- Sufficient care must be taken on the fire not only when replenishing but also handling fuel. It could cause fire or explosion.
- Securely close the oil tank cap. Fuel may leak if the cap is tightened aslant. It will never leak if the cap is tightened properly.
(Excluding: TL tank cap breather type)

Inspection of clogging

- Check the cooling fins, around the muffler and cooling air inlet for trash or withered grasses trapped.
- Remove them if necessary

Inspection of air cleaner

- Is not fouled the air cleaner element?
- When the element is fouled or it is not impregnated with oil, inspect and service it in accordance with "Inspection and servicing before each operation"

Inspection of screws and nuts

- Check respective sections for loose or missing screws or nuts.
- Service them if necessary.

Inspection of fuel pipes

- Check for cracks or fissures on the fuel pipe and grommet, disconnection or fuel leakage from joints on the fuel tank and carburetor.

CAUTION

Cracks, fissures or disconnection from joints could cause fire or explosion by leaked fuel. Service or replace damaged fuel pipe and grommet.

- the sharp chain. Even a non-moving chain can cause serious cuts to yourself or persons you bump into with an exposed chain.
- Secure the machine during transport.

PARTS OVERVIEW

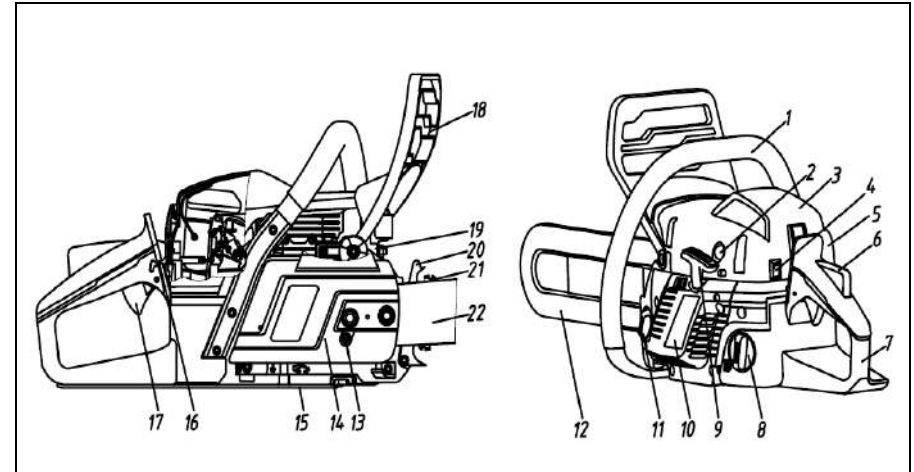

1.	Front handle	12.	Bar protector
2.	Oil cup	13.	Chain tensioning screw
3.	Gland	14.	Clutch cover
4.	Stop switch	15.	Oil pump adjustment screw
5.	Cylinder cover	16.	Choke knob
6.	Throttle control latch	17.	Throttle control
7.	Rear handle	18.	Front hand guard
8.	Fuel tank	19.	Muffler
9.	Starter handle	20.	Bumper spike
10.	Starter	21.	Chain
11.	Chain oil tank	22.	Bar

INSTALLING GUIDE BAR AND SAW CHAIN



WARNING

The saw chain has very sharp edges. Use thick protective gloves for safety.

- 1) Pull the guard towards the front handle to check that the chain brake is not on.
- 2) Loosen the nuts and remove the chain cover.
- 3) Install the bar over the bar bolts. Place the bar in its rearmost position. Place the chain the drive sprocket locate it in the groove on the bar. Begin on the top edge of the bar

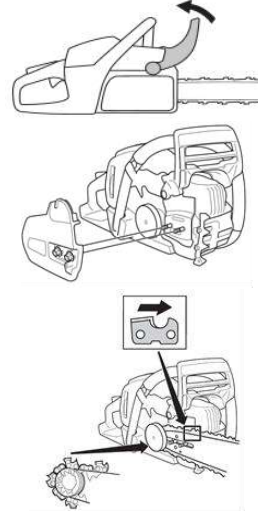

WARNING

Make sure that the edges of the cutting links are facing forward on the top edge of the bar.

- 4) Fit the chain cover and locate the chain adjuster pin in the hole in the bar. Check that the drive links of the chain fit correctly over the drive sprocket and that the chain is correctly located in the groove in the bar. Tighten the bar nuts finger tight.
- 5) Tension the chain by turning the chain tensioning screw clockwise using the combination spanner.

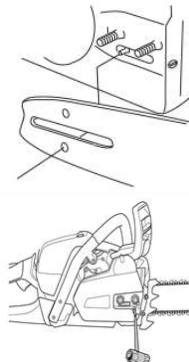

INSPECTION BEFORE OPERATING THE ENGINE

FUEL: Use mixed oil of ordinary regular petrol for vehicle and special 2-cycle engine oil with the proportion as shown by the following table.

Mixing ratio (Volumetric ratio):

Petrol : 2-cycle engine oil
40: 1

- Do not use degenerated oil (with sour smell).
- (It could cause engine trouble such as the starting error, insufficient output, etc.)
- Make sure to clean spilled fuel. It could foul clothes or cause fire.
- Do not use 4-cycle engine oil. (It could cause fouled plug, bound piston ring, clogged muffler, or other problem.)
- Take care while handling petrol. (As there is a risk of explosion.)

ADJUSTMENT OF THROTTLE WIRE:

Adjust the play on the throttle wire to 0.5 ~ 1.0 mm.

LARGER PLAY

- It could cause the starting trouble.
- Revolution speed could rise unexpectedly when the external wire of throttle wire comes off from the position.

NO PLAY

- Driven equipment may fail to stop even if the throttle lever is returned.

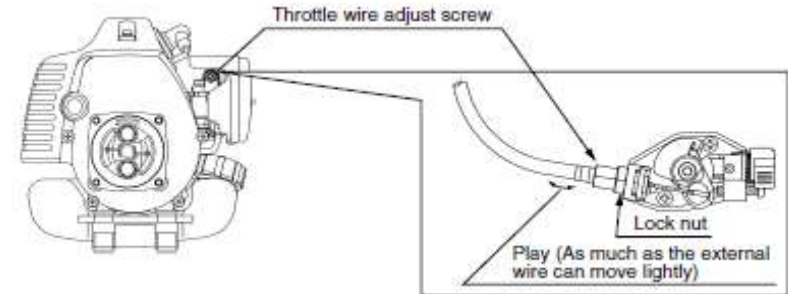

INSPECTION OF RESPECTIVE SECTIONS:

Make sure to inspect these sections before operating the engine.

Inspection of fuel

- Is sufficient quantity of oil reserved?
- Is not the fuel degenerated?
- Use the proper fuel referring to the "Fuel" section.

CAUTION

- Do not operate the engine when grass, leaves or inflammable substances are sticking in or around the muffler.
- Do not touch parts of muffler or engine at high temperatures. (There is risk of burns.)
- Do not touch the ignition plug or high-voltage cord during operation. (There is risk of electric shock or physical injury.)
- Make sure to stop the engine whenever the work is interrupted or moving the engine to another place.
- Do not operate the engine alone. (It must be connected to the driven equipment when it is operated).
- Check frequently the parts used on the fuel line for cracks or leakage, and replace them if necessary.
- Remove dirt, grass or other trash from the cooling fins and the cooling air inlet. (Make sure to stop the engine and the driven equipment before the cleaning.)
- Make sure to use always new petrol. (Old petrol may cause sticky substance adhering at the inside of carburetor causing trouble in operation.)
- Before starting the engine, confirm that the area of radius 15 m around it is evacuated and no tank filled with fuel, or others are not left over.
- Use only genuine parts supplied from the manufacturer. Use of parts other than the genuine parts could cause engine trouble or premature abrasion.

Note: Important safety items quoted in this manual do not necessarily cover all situations or conditions that could occur. Although sufficient care has been taken to assure the safety of the engine, operators or service personnel must observe necessary precautions to operate it safely and protect themselves from possible dangers.

COMPONENTS OVERVIEW

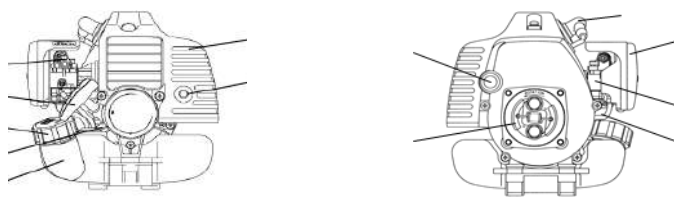

1. Recoil starter grip	8. Engine switch (Types vary depending on the specifications.)
2. Starter lever	9. Clutch
3. Cooling air inlet	10. Ignition plug cap
4. Fuel tank cap	11. Air cleaner
5. Fuel tank	12. Carburetor
6. Muffler	13. Priming button
7. Exhaust outlet (Types vary depending on the specifications.)	

- 6) The chain is correctly tensioned when it does not sag from the underside of the bar, but can still be turned easily by hand. Hold up the bar tip and tighten the bar nuts with the plug wrench.
- 7) When fitting a new chain, the chain tension has to be checked frequently until the chain is run-in. Check the chain tension regularly. A correctly tensioned chain ensures good cutting performance and long life.

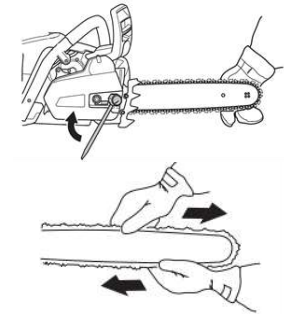

NOTE

A new chain will expand its length in the beginning of use. Check and readjust the tension frequently as a loose chain can easily derail or cause rapid wear of itself and the guide bar.

FUEL AND CHAIN OIL

FUEL

The machine is equipped with a two-stroke engine and must always be run using a mixture of petrol and two-stroke oil. It is important to accurately measure the amount of oil to be mixed to ensure that the correct mixture is obtained. When mixing small amounts of fuel, even small inaccuracies can drastically affect the ratio of the mixture.

Petrol

- Use good quality petrol.
- The lowest recommended octane grade is 90.

Two-stroke oil

- Use two-stroke engine oil, which is specially formulated for our air-cooled two stroke-engines
- Never use oil intended for four-stroke engines

Recommended Mixing Ratio:

Condition	Petrol: oil
Up to 100 hours use	25:1
After 100hours use	30:1



25:1 Mix Chart

Petrol(L)	1	2	3	4	5
2-cycle oil (ml)	40	80	120	160	200

30:1 Mix Chart

Petrol(L)	300	600	900	1200	1500
2-cycle oil (ml)	10	20	30	40	50

WARNING

- Keep open flames away from the area where fuel is handle or stored.
- Mix and store fuel only in an approved gasoline container.

NOTE

Most engine troubles are caused, directly or indirectly, by the fuel used in the machine. Take special care not to mix engine oil used for 4 stroke engines.

CHAIN OIL

Use motor oil SAE # 30- SAE # 40 in summer and SAE # 20 in winter.

NOTE

Do not use wasted or regenerated oil that can cause damage to the oil pump.

FUELING

- Never refuel the machine while the engine is running.
- Make sure there is plenty of ventilation when refueling or mixing fuel (gasoline and 2-stroke oil).
- Move the machine at least 3m from the refueling point before starting it.
- If you have spilled fuel or chain oil on the machine, wipe off the spillage and allow remaining fuel to evaporate.
- If the machine is leaking fuel. Check regularly for leaks from the fuel cap and fuel lines

2 - STROKE PETROL ENGINE- MANUAL

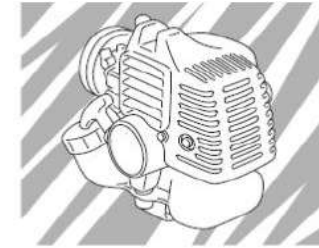

BEFORE GETTING STARTED

This manual describes various cautions necessary to operate the engine properly. Before starting the engine, read the manual and understand the proper method of use. (Improper use of the engine could result in accident or injury.)

Use the engine after reading and understanding also the manual of equipment driven by the engine.

Keep the manual at a safe place where you can refer whenever needed.

SAFETY INSTRUCTIONS

- No person who does not understand the content of this manual should be allowed to operate the engine.
- Engine should not be operated indoors or in places with poor ventilation. (Exhaust gas contains odorless and harmful carbon monoxide.)
- Do not insert in or approach hands or foot near the moving or revolving sections.
- Do not store, spill or use petrol at the vicinity of fire, stove, furnace or devices using the pilot flame or sparks like water heater or others. (There is risk of explosion.)
- Do not refill the fuel indoors or at a place not well ventilated.
- Do not smoke while filling the fuel.
- Do not remove the fuel tank cap or refill the fuel while the engine is still running or immediately after operation when the engine is still hot. (Wait for more than 2 minutes after terminating the operation before refilling the fuel.)
- Do not operate the engine when petrol has spilled, smell of petrol is felt as there is a risk of explosion.
- Do not adjust the setting engine speed unnecessarily.
- Do not check sparks while the ignition plug is removed.
- Do not operate the engine with the muffler or air cleaner cover removed. (Inspect particularly the muffler at regular intervals for loose mounting screws, breakage or leakage, and repair or replace it if any abnormality is observed.)

KK-No	KK-Name	Qty	KK-No	KK-Name	Qty
B-25	Front Handle	1	B-59	Bolt Allen M5x20	2
B-26	Fuel Pipe Short	1	B-60	Bolt Allen M5x20 W/P Washer	4
B-27	Grommet Fuel Pipe	1	B-61	Tapping Screw	2
B-28	Fuel Pipe Long	1	B-62	Screw ST M4. 8 x 12	1
B-29	Fuel Filter	1	B-63	Cushion Board	1
B-30	Throttle Rod	1	B-64	Block Starter Handle	1
B-31	Bedding Spring	2	B-65	N/A	1
B-32	Bedding Spring Seat	2	B-66	Tensioner Pin	1
B-33	Fuel Tank Cap	1	B-67	Screw ST Allen M6x20	4
B-34	Pin B4 x 28-Trigger	1	B-68	Chain Bar 325-58-78DL-20"	1
B-35	Trigger	1	B-69	Chain 325-58-78DL-20"	1

1. Untwist and remove fuel cap. Rest the cap on a dustless place.
2. Put fuel into the tank to 95% of the full capacity.
3. Fasten the fuel cap securely and wipe up any fuel spillage around the unit.

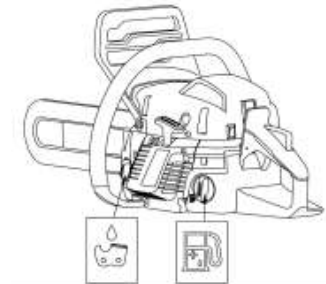

CHECKING OIL SUPPLY

Check the chain lubrication each time you refuel. After starting the engine, run the chain at medium speed and see if chain oil is scattered off as shown in the figure.

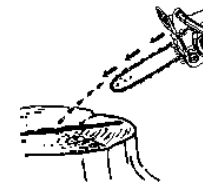

ADJUSTMENT OF THE OIL PUMP

NOTE

The saw chain oil tank and the fuel tank are designed so that the fuel runs out before the saw chain oil.

Adjustments are made by turning the oil pump adjustment screw using a screwdriver or combination spanner. The machine is supplied from the factory with the screw set to middle position. Turning the screw clockwise will reduce the oil flow and turning the screw anti-clockwise will increase the oil flow.

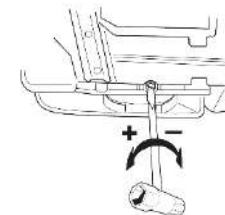

NOTE

Be sure to refill the chain oil tank every time when refueling the unit.

STARTING AND STOPPING

Starting the Engine:

1. The chain brake should be activated when starting the chain saw. Activate the chain brake by pushing the front hand guard forwards.



2. Press the oil cup repeatedly until fuel begins to fill the diaphragm (about 3-6 times). The oil cup need not be completely filled.

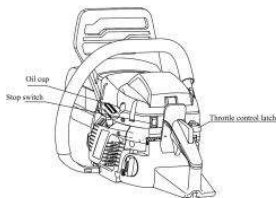

3. Move the switch to "ON" position.

4. Pulling out the choke knob, the choke is closed.

5. Grip the front handle with your left hand. Put your right foot into the boot grip through the lower section of the rear handle pressing the machine against the ground.

6. Pull the starter handle with your right hand and pull out the starter cord slowly (about 3-4 times) until you hear a "puff" sound.



7. By disengaging the throttle latch in order to the choke is opened. Pull the starter handle with your right hand and pull out the starter cord rapidly until the engine starts.



8. Pull the front hand guard back towards the front handle. The chain saw is now ready for use.



KK-No	KK-Name	Qty	KK-No	KK-Name	Qty
B-1	Front Damper (RC)	1	B-36	Trigger Torsion Spring	1
B-2	Washer Guidance Lump	1	B-37	Base	1
B-3	Guidance Lump	1	B-38	Trigger control Rack	1
B-4	Recall Spring	1	B-39	Handle Cover	1
B-5	Dental Plate	1	B-40	Tensioner Cover Plate (RC)	1
B-6	Cylinder Spring Seat	1	B-41	Passive Tension Gear	1
B-7	Cylinder Spring	1	B-42	Active Tension Gear	1
B-8	Chain Catcher	1	B-43	Dust Shield (RC)	1
B-9	Grommet Fuel Pipe(Small)	1	B-44	Brake Spring (RC)	1
B-10	Balancer Pipe	1	B-45	Brake Spring Cover Plate (RC)	1
B-11	Grommet Balancer	1	B-46	Brake Strap (RC)	1
B-12	Balancer Assy	1	B-46-1	Brake Control Rod(RC)	1
B-13	Support Rubber	2	B-47	Right Cover (RC)	1
B-14	Guide Flow Cover	1	B-48	Pin(Main Level)	1
B-15	Bolt Star M5x12	1	B-49	Main Level	1
B-16	Washer (Rope Reel)	1	B-50	Stop ring outer 5	1
B-17	Starter Rope	1	B-51	Bolt Allen M5x10 W/P Washer	2
B-18	Rope Reel	1	B-52	Bolt Allen M5x8 W/P Washer	2
B-19	Gland Recoil Spring	1	B-53	Bolt Allen M4x12	1
B-20	Recoil Spring	1	B-54	Bolt Allen M4x6	1
B-21	Starter Cover	1	B-55	Bolt Allen M5x20	2
B-22	Starter Handle	1	B-56	Screw ST Pan Head M5x20	1
B-23	Oil Tank Cap	1	B-57	Screw (Front Damper (RC))	2
B-24	N/A	1	B-58	Screw ST Pan Head M5x20	3

PARTS DIAGRAM & LIST- BODY

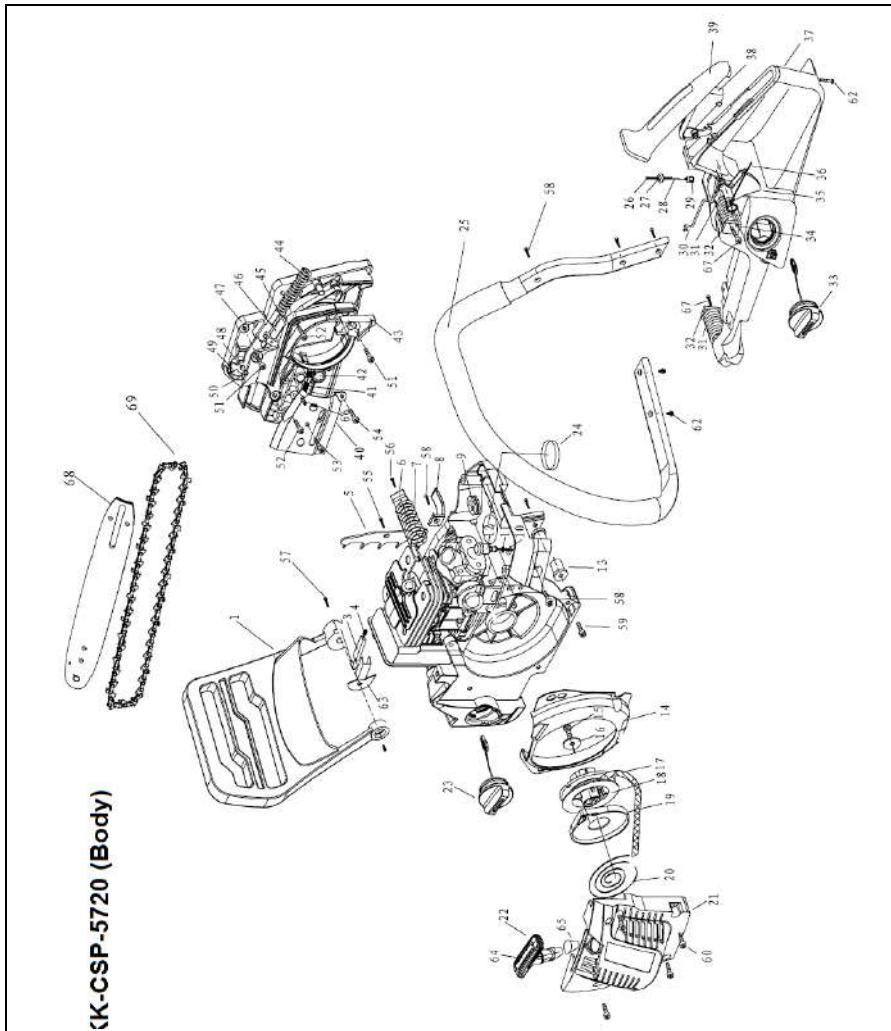

NOTE

When restarting immediately after stopping the engine, leave the choke knob at the open position.

WARNING

Do not start the engine while holding the chainsaw with hand. The saw chain may touch your body and is very dangerous.

Winter Use

The intermediate wall is designed so it can be adjusted for running in cold weather, so that preheated air from the cylinder can pass into the carburetor space preventing icing of the air filter, etc.

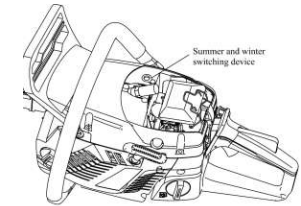

Break

1. Don't accelerate abruptly due to bad lubrication of the engine at the beginning of start-up.
2. Avoid the speedy idle motion and over speed motion. If the engine runs at high speeds, it not only shortens the life of the engine but also causes more problems in the engine.

Stopping the Engine

1. Release the throttle lever to allow the engine to idle.
2. Set the switch to the "OFF" position.

SAWING

WARNING

- Before proceeding to your job, read "Safety Precautions" section it is recommended to first practice sawing easy logs. This also helps you get accustomed to your unit.
- Always follow the safety regulations. The chain saw must only be use for cutting wood. It is forbidden to cut other types of material. Vibrations are not recommended. do not use the chain saw as a lever for lifting moving or splitting objects .Do not lock it over fixed stands ,it is forbidden to hitch tools or applications to the p.t.o that are not specified by the manufacturer.
- It is not necessary to force the saw into the cut. Apply only light pressure while running the engine at full throttle.
- When the saw chain is caught in the cut, do not attempt to pull it out by force, but use a wedge or a lever to open the way.

- Never use a chain saw by holding it with one hand. A chain saw is not safely controlled with one hand. Always have a secure, firm grip around the handles with both hands.
- Always use full throttle when cutting!
- Reduce the speed to idle after every cut (running the engine for too long at full throttle without any load, i.e. without any resistance from the chain during cutting, can lead to serious engine damage)
- After working for a long time, release the throttle lever to allow the engine to idle and run 3~5 minutes, for preventing the machine parts (ignition, carburetor) from overheating.
- Always start a cut with the chain rotating at full speed and bumper spike in contact with the wood.
- Bumper spike as a pivot when chain saw is sawing ,Some of the weight of chain saw and reacting force of sawing have effect on the wood, lighten the intensity of labor.

Guard Against Kickback

1. This saw is equipped with a chain brake that will stop the chain in the event of kickback if operating properly. You must check the chain brake operation before each usage by running the front hand guard forward. The chain should stop immediately with the engine at full speed. If the chain is slow to stop or does not stop, replace the brake band and clutch drum before use.
2. It is extremely important that the chain brake be checked for proper operation before each use and that the chain be sharp in order to maintain the kickback safety level of this saw, removal of the safety devices. Inadequate maintenance, or incorrect replacement of the bar or chain may increase the risk or personal injury due to kickback.

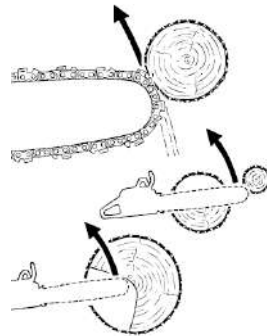

Basic Cutting Technique

Decide the felling direction considering the wind, lean of the tree, location of heavy branches, ease of job after felling and other factors.

- (1) While cleaning the area around the tree, arrange a good foothold and retreat path.
- (2) Make a notch cut one-third of the way into the tree on the felling side.
- (3) Make a felling cut from the opposite side of the notch and at a level slightly higher than the bottom of the notch.



- (1) Notch cut
- (2) Felling cut
- (3) Felling direction

TECHNICAL SPECIFICATIONS

Chain saw Model	KK-CSP-5720	KK-CSP-8650
Guide bar Size (in.)	51cms (20")	46cms (18")
Displacement(cc)	50.8	50
Rated power (kW)	2.2	
RPM	9000	
Fuel	Mixture (Petrol 25:Two-cycle oil 1)	
Fuel tank capacity(ml)	540	600
Chain (Oregon) oil	Motor oil SAE 10W-30	
Oil tank capacity(ml)	280	250
Carburetor	Diaphragm type	
Ignition	C.D.I	
Spark plug	CMR6A	
Oil feeding system	Automatic pump adjuster	
Starting system	Recoil Starter	
Guide bar Type	Sprocket nose	
Saw Chain Pitch(in.)	0.325	
Chain saw without bar or chain, empty tanks, (kg)	5.8	5.8
Idle speed (r/min)	3200±280	
Clutch speed (r/min)	5000±300	
Dimensions(L*W*H)(mm)	430×180×260	
Sound level dB(A)	≤115	
Vibration level (m/s ²)	Front handle	≤5.5
	Rear handle	≤7.5

Problem	Probable Cause	Remedy
	Faulty magneto or internal short	Replace the magnet
Engine doesn't sound right	Overheated cylinders	Replace the cylinder
	Overload operation	Right quantities of petrol and oil should be mixed to enable proper lubrication
	Faulty mixture or incorrect ratio	
	Internal engine damage	Replace the necessary spares/contact service person
Slow acceleration	Carburetor not adjusted properly or faulty compression	Adjust the carburetor gap properly
	Poor gasoline oil quality	Use good quality gasoline-oil mixture.
	Carbon pile up	Clean the carbon

The Engine Suddenly Stopped

Probable Cause	Remedy
Fuel is used up	Add fuel
Spark plug got contaminated with oily deposits	Clean the oily deposits

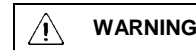

WARNING
When you fell a tree, be sure to warn person of the danger

Bucking and Limbing



- Always ensure your foothold. Do not stand on the log.
 - Be alert to the rolling over of a cut log. Especially when working on a slope, stand on the uphill side of the log.
 - Follow the instructions in "For safe operation" to avoid kick back of the saw.
- Before starting work, check the direction of bending force inside the log to be cut. Always finish cutting from the opposite side of bending direction to prevent the guide bar from being caught in the cut.

A Log lying on the ground

Saw down halfway, then roll the log over and cut from the opposite side.

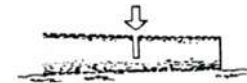

A Log hanging off the ground

In area A, saw up from the bottom one-third and finish by sawing down from the top. In area B, saw down from the top one-third and finish by sawing up from the bottom

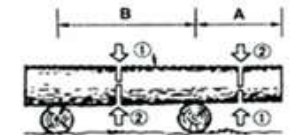

Cutting Limbs of Fallen Tree

First check to which side the limb is bent. Then make the initial cut from the bent side and finish by sawing from the opposite side.

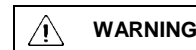
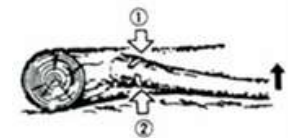

WARNING
Be alert to the springing back of a cut limb.

Pruning of Standing Tree

Cut up from the bottom, finish down from the top.

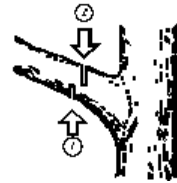

MAINTENANCE

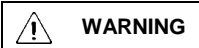

WARNING

Before cleaning, inspecting, or repairing your unit, make sure that engine has stopped and is cool. Disconnect the spark plug to prevent accidental starting.

Maintenance after Each Use

1. Air filter and Gland



WARNING

The air filter and gland must be regularly cleaned to remove dust and dirt in order to avoid Carburetor malfunctions.

- Remove the air filter after taking off the Cylinder cover, Split the air filter into halves. When refitting make sure that the air filter seals tightly against the filter holder. Clean the filter by brushing or shaking it.
- The filter can be cleaned more thoroughly by washing it in water and detergent.
- An air filter that has been in use for a long time cannot be cleaned completely. The filter must therefore be replaced with a new one at regular intervals. A damaged air filter must always be replaced.

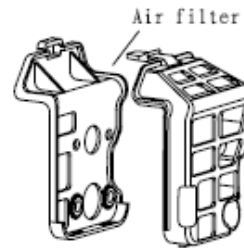

No fuel in the carburetor	No fuel in the tank	Fill the tank with fuel
	Fuel valve is faulty or fuel tank air vent is plugged.	Clear air vent hole
	Lines are bent	Replace lines

2. Engine Fails To Run Smooth:

Problem	Probable Cause	Remedy
No power	Air cleaner element is plugged up.	Clean or replace air cleaner if necessary
	Air has entered fuel line joints.	Clear the fuel line
	Faulty choke lever	Replace choke lever
	Carbon build up on cylinder muffler.	Clean the muffler
Compression is bad	Burnt spark plugs	Replace the spark plug
	Short in cable	Replace the cable
	Bad mixture or piston ring wear.	Replace the piston ring
Engine overheated	Marks on cylinder. Cracks in the piston head	Replace the piston
	Fuel is too low (mixture is too thin).	Engine over oiling.
	Faulty mixture, not enough mixture.	Clear the lines
	Carbon piled up, overloaded operation.	Clean the carbon
	Faulty spark plugs.	Replace the spark plugs
Inaccurate explosion	Plugged cylinder or coolant lines	Clean the coolant lines
	Carburetor not adjusted properly.	Adjust the carburetor gap properly
	Faulty spark plugs.	Replace the spark plug

After every cutter has been set, check the depth gauge and file it to the proper level as illustrated.



WARNING

Be sure to round off the front edge to reduce the chance of kickback or tie-strap breakage.

Use the flat file to file off the tip of the depth gauge that protrudes through the depth gauge tool. The depth gauge setting is correct when you no longer feel resistance as you draw the file along the depth gauge tool.

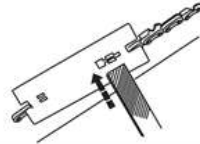

TROUBLESHOOTING

1. When Engine Fails To Start:

Problem		Probable Cause	Remedy
There is fuel, but spark plugs fail to ignite.	There is power at the terminal.	Drawing too much fuel	Tuning the carburetor
		Faulty spark plug gap.	Adjust the spark plug gap
	No power at the terminal	Faulty spark plug insulation.	Replace the spark plug
		Faulty TCI unit or broken wire	Replace the ignition coil.
There is fuel and spark plug ignites	A break or short in the ignition coil.	Tighten the spark plug	
	Compression is good		Adjust the carburetor
	Compression is bad		Faulty packing
Spark plugs not tightened properly		Tighten the spark plug	
Piston rings are sticking		Replace the piston ring	

2. Guide bar

When the guide bar is dismantled, remove Saw dust in the bar groove and the oiling port.

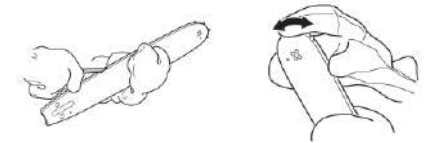

Grease the nose sprocket from the feeding port on the tip of the bar.



To prolong the life of the bar you should turn it over daily.



3. Oiling Port

Remove the guide bar and check the oiling port for clogging.



4. Chain Brake

Brush off any wood dust, resin and dirt from the chain brake and clutch drum. Dirt and wear can impair operation of the brake.

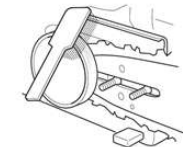

Periodical Service Points:

1. Cooling System

Dust clogging between the cylinder fins will cause overheating. Removing the Starter and the cylinder cover. Clean the cooling system with a brush once two week.

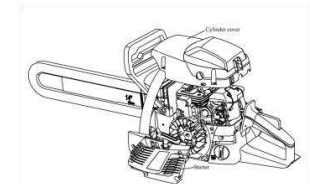

2. Spark Plug

Clean the electrodes with a wire brush and reset the gap to 0.5~0.65mm as necessary.

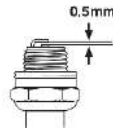

3. Sprocket

Check for cracks and for excessive wear interfering with the chain drive. If the crack is obvious, replace it with new one. Never fit a new chain on a worn sprocket, or a worn chain on a new sprocket.

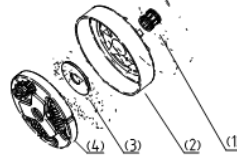

(1) Needle bearing (2) Sprocket
(3) Spacer (4) Clutch

Sprockets have a needle bearing on the drive shaft, which has to be greased regularly (once a week). Use only high quality bearing grease or engine oil

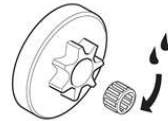

4. Chain Catcher

Check that the chain catcher is not damaged and is firmly attached to the body of the chain saw.



5. Muffler

- Regularly check if the muffler is securely attached to the machine.
- Some mufflers are equipped with a special spark arrestor screen. If your machine has this type of muffler, you should clean the screen at least once a week. This is best done with a wire brush. A blocked screen will cause the engine to overheat and may lead to serious damage



6. Saw Chain

WARNING

It is very important for smooth and safe operation to keep the cutters always sharp.

The chain needs sharpening if you observe any of the below mentioned:

- Sawdust becomes powder-like.
- You need extra force to saw in.
- The cut way does not go straight
- Vibration increases
- Fuel consumption increases

Cutter Setting Standards:

WARNING

Be sure to wear safety gloves.

When you sharpen a cutting tooth there are four important factors to remember.

- Filing angle

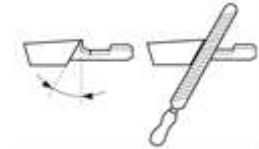

- Cutting angle



- File position



- Round file diameter



Always file cutting teeth from the inside face. Reduce the pressure on the return stroke. File all the teeth on one side first, then turn the chain saw and file the teeth on the other side.

