

Important: (1) Normal maintenance and adjustments to the product is the responsibility of the customer. (2) Normal wear and tear is not covered under warranty. (3) Rubber/plastic parts and consumables such as blades, clutch and clutch-bell, spark-plugs, nylon line, air-filters, fuel-filters, oil seals etc. are not covered under the warranty.

No Warranty On Electrical Motor / Electrical Parts / Battery Etc.

Incidental / Consequential Loss: KisanKraft Limited or its manufacturers will not be liable for general damages, including bodily injuries, or for incidental or consequential damages including, but not limited to, loss of use, loss of profits, loss of production, expense of substitute equipment or other commercial loss or damage.

Limitation of Liability: This limited warranty is in lieu of all other express warranties, obligations, or liabilities. Any implied warranties, obligations or liabilities, including, but not limited to, any implied warranty of merchantability shall be limited in duration to the applicable warranty period. Any action for breach of any warranty hereunder, including, but not limited to, any implied warranty of merchantability must be brought within the applicable warranty period.

Modifications of Warranty: No agent, representative, dealer, or employee of KisanKraft Limited or any of its manufacturers has the authority to increase or alter the obligations of this warranty.

Assignment / Transfer of warranty: The warranty cannot be assigned and shall not transfer if the product is resold by the first buyer. The above warranties are extended to the first end user (original purchaser), and no warranty is made, nor authorized to be made assignable on resale by the first end user.

What you must do to obtain limited warranty service: To obtain performance of any obligation under this warranty for failure during the applicable warranty period, deliver the defective product, to the nearest Authorized Dealer. KisanKraft Limited, its manufacturers and its dealers reserve the right to inspect the claimed defective part(s) to determine if the malfunction is the result of a defect covered by this warranty. Please note that the decision of KisanKraft Limited with respect to any warranty claim is final.

Receipt is required for availing warranty services

Jurisdiction: All disputes are subject to Bangalore court's jurisdiction.

Our Products

- ◆Chainsaws◆Brush Cutters and Accessories◆Harvesters◆
- ◆Engines and Water Pumps◆Hand Tools◆Garden Tools◆
- ◆Cultivators and Accessories◆Sprayers and Accessories◆
- ◆Transplanter and Post Hole Digger ◆Milking Machines◆

This warranty is null & void, if you fail to register the warranty with KisanKraft by sending the KisanKraft Copy with dealer's stamp.

KisanKraft Limited (formerly known as KisanKraft Machine Tools P Ltd)

🌐: www.kisankraft.com ✉: info@kisankraft.com ☎: +91.80.22178200

Product	Pole Pruner/ Palm Harvester	KisanKraft Invoice Date	
Brand	KisanKraft	KisanKraft Invoice No.	
Model	<input type="checkbox"/> KK-PP2-8627 <input type="checkbox"/> KK-PH2-215		
WARRANTY PERIOD	6 MONTHS	FOR THE SPECIFIED PERIOD FROM THE DATE OF SALE OR DELIVERY WHICHEVER IS EARLIER.	
Dealer's Invoice Date		Dealer's Invoice No.	
Buyer's Info (Name, Address, Phone, etc.):		Dealer's Stamp (Address, Phone, TIN, etc.):	
Buyer's Sign		Dealer's Sign	

What is covered: KisanKraft Limited and its manufacturers warrant this product to be free from defects in material or workmanship. All parts defective in material and workmanship are covered.

This warranty will only cover defects arising under normal usage.

This warranty is limited to repair or replacement by KisanKraft Limited or its manufacturers at the premises of Authorized Dealers, of such parts as appear to KisanKraft or its manufacturers, upon inspection, to be defective in material and/or workmanship. KisanKraft or its manufacturers make no warranty with respect to trade accessories not manufactured or sold by them.

What is not covered: The *warranty shall become null and void* and neither KisanKraft Limited nor any of its manufacturers, nor its authorized dealers assumes any responsibility, if the failure was caused by the following:

- (1) Operation of product with incorrect fuel or lubricants,
- (2) Incorrect usage of machine or misuse,
- (3) Lack of maintenance,
- (4) Negligence,
- (5) Accident or physical damage,
- (6) Repairs made by unauthorized parties and/or with unauthorized parts,
- (7) Improper set up, adjustments, tampering or altered products

Note: *The purchase is not contingent upon a product demonstration. The purchaser shall satisfy himself with the product, including any product demonstration or verification of any function, before buying. KisanKraft Limited or its authorized dealers, including online sellers, shall not be liable to give any on-site demonstration after purchase of any of the product.*

This warranty is null & void, if you fail to register the warranty with KisanKraft by sending the KisanKraft Copy with dealer's stamp.

KisanKraft Limited (formerly known as KisanKraft Machine Tools P Ltd)

🌐: www.kisankraft.com ✉: info@kisankraft.com ☎: +91.80.22178200

Important: (1) Normal maintenance and adjustments to the product is the responsibility of the customer. (2) Normal wear and tear is not covered under warranty (3) Rubber/plastic parts and consumables such as blades, clutch and clutch-bell, spark-plugs, nylon line, air-filters, fuel-filters, oil seals etc. are not covered under the warranty.

No Warranty On Electrical Motor / Electrical Parts / Battery Etc.

Incidental / Consequential Loss: KisanKraft Limited or its manufacturers will not be liable for general damages, including bodily injuries, or for incidental or consequential damages including, but not limited to, loss of use, loss of profits, loss of production, expense of substitute equipment or other commercial loss or damage.

Limitation of Liability: This limited warranty is in lieu of all other express warranties, obligations, or liabilities. Any implied warranties, obligations or liabilities, including, but not limited to, any implied warranty of merchantability shall be limited in duration to the applicable warranty period. Any action for breach of any warranties hereunder, including, but not limited to, any implied warranty of merchantability must be brought within the applicable warranty period.

Modifications of Warranty: No agent, representative, dealer, or employee of KisanKraft Limited or any of its manufacturers has the authority to increase or alter the obligations of this warranty.

Assignment / Transfer of warranty: The warranty cannot be assigned and shall not transfer if the product is resold by the first buyer. The above warranties are extended to the first end user (original purchaser), and no warranty is made, nor authorized to be made assignable on resale by the first end user.

What you must do to obtain limited warranty service: To obtain performance of any obligation under this warranty for failure during the applicable warranty period, deliver the defective product, to the nearest Authorized Dealer. KisanKraft Limited, its manufacturers and its dealers reserve the right to inspect the claimed defective part(s) to determine if the malfunction is the result of a defect covered by this warranty. Please note that the decision of KisanKraft Limited with respect to any warranty claim is final.

Receipt is required for availing warranty services

Jurisdiction: All disputes are subject to Bangalore court's jurisdiction.

Our Products	<ul style="list-style-type: none"> ◆Chainsaws◆Brush Cutters and Accessories◆Harvesters◆ ◆Engines and Water Pumps◆Hand Tools◆Garden Tools◆ ◆Cultivators and Accessories◆Sprayers and Accessories◆ ◆Transplanter and Post Hole Digger ◆Milking Machines◆
---------------------	--

This warranty is null & void, if you fail to register the warranty with KisanKraft by sending the KisanKraft Copy with dealer's stamp.

KisanKraft Limited (formerly known as KisanKraft Machine Tools P Ltd)

🌐: www.kisankraft.com ✉: info@kisankraft.com ☎: +91.80.22178200

Product	Pole Pruner/ Palm Harvester	KisanKraft Invoice Date	
Brand	KisanKraft	KisanKraft Invoice No.	
Model	<input type="checkbox"/> KK-PP2-8627 <input type="checkbox"/> KK-PH2-215		
WARRANTY PERIOD	6 MONTHS	FOR THE SPECIFIED PERIOD FROM THE DATE OF SALE OR DELIVERY WHICHEVER IS EARLIER.	
Dealer's Invoice Date		Dealer's Invoice No.	
Buyer's Info (Name, Address, Phone, etc.):		Dealer's Stamp (Address, Phone, TIN, etc.):	
Buyer's Sign		Dealer's Sign	

What is covered: KisanKraft Limited and its manufacturers warrant this product to be free from defects in material or workmanship. All parts defective in material and workmanship are covered.

This warranty will only cover defects arising under normal usage.

This warranty is limited to repair or replacement by KisanKraft Limited or its manufacturers at the premises of Authorized Dealers, of such parts as appear to KisanKraft or its manufacturers, upon inspection, to be defective in material and/or workmanship. KisanKraft or its manufacturers make no warranty with respect to trade accessories not manufactured or sold by them.

What is not covered: The *warranty shall become null and void* and neither KisanKraft Limited nor any of its manufacturers, nor its authorized dealers assumes any responsibility, if the failure was caused by the following:

- (1) Operation of product with incorrect fuel or lubricants,
- (2) Incorrect usage of machine or misuse,
- (3) Lack of maintenance,
- (4) Negligence,
- (5) Accident or physical damage,
- (6) Repairs made by unauthorized parties and/or with unauthorized parts,
- (7) Improper set up, adjustments, tampering or altered products

Note: *The purchase is not contingent upon a product demonstration. The purchaser shall satisfy himself with the product, including any product demonstration or verification of any function, before buying. KisanKraft Limited or its authorized dealers, including online sellers, shall not be liable to give any on-site demonstration after purchase of any of the product.*

This warranty is null & void, if you fail to register the warranty with KisanKraft by sending the KisanKraft Copy with dealer's stamp.

KisanKraft Limited (formerly known as KisanKraft Machine Tools P Ltd)

🌐: www.kisankraft.com ✉: info@kisankraft.com ☎: +91.80. 22178200



Wide Range of Products for Every Need



For more information give **MISSED CALL: 07676065555**



Many of our products have BIS: ISI certification.



User Manual

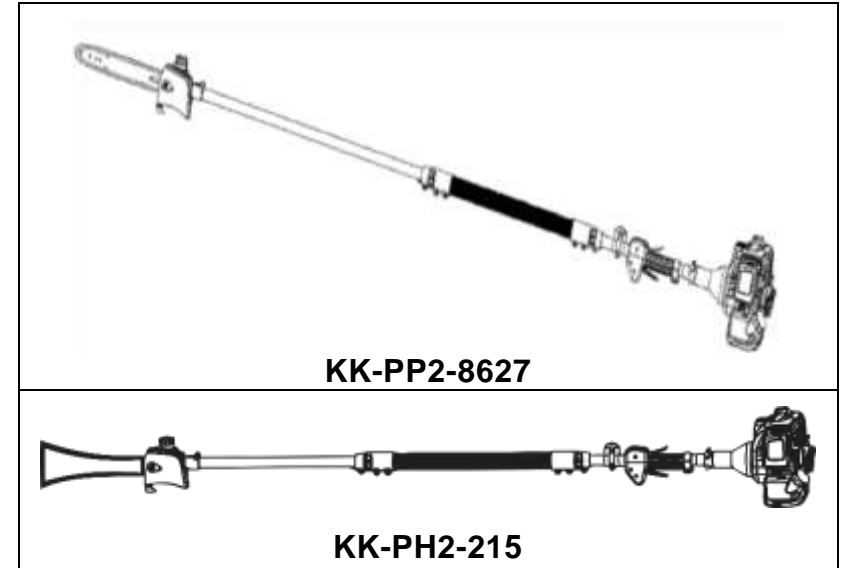

KisanKraft Limited

(Formerly known as KisanKraft Machine Tools Pvt Ltd)

Sri Huchhanna Tower, #4, 1st Main, 7-A Cross, Maruthi Layout, Dasarahalli,
 HAF Post, Hebbal, Bangalore 560024, Karnataka, INDIA

- ◆ Bangalore (HO) ◆ Ahmedabad ◆ Bhopal ◆ Bhubaneswar ◆ Coimbatore ◆
- ◆ Ernakulam ◆ Guwahati ◆ Patna ◆ Hinudpur ◆ Hubli ◆ Hyderabad ◆
- ◆ Jaipur ◆ Karnal ◆ Kolkata ◆ Lucknow ◆ Nagpur ◆ Pune ◆ Raipur ◆ Shimla ◆

CONTENTS

Before Getting Started7

Application7

Safety Instructions8

Main Parts14

Using the Unit14

Mounting the Bar and Chain..... 16

Adjusting the Throttle Cable 17

Fuel and Oil Mixture..... 17

Chain Lubricant..... 18

Preparing for Operations19

Operating Instructions22

Taking Care of the Guide.....23

Engine Management23

Storage and Transportation27

Checking and Replacing the Chain Sprocket28

Maintaining and Sharpening the Saw Chain28

Inspections and Maintenance31

Troubleshooting.....32

Technical Specifications33

Engine Parts Diagram & List-KK-PP2-862734

Body Parts Diagram & List-KK-PP2-862736

Body Parts Diagram & List- KK-PH2-21541

2 Stroke Petrol Engine- Manual.....45



KisanKraft has a large range of products to serve the farmers. A list of our products is given below:

<p>Brush Cutters and Accessories</p> <ul style="list-style-type: none"> Brush Cutter/Power Weeder Backpack Brush Cutter Tea Pruner Pole pruner with Engine Reaper Attachment Blades-Circular Blades (2 &3 points) Baffle Nylon Rope Tap & Go <p>Chainsaws</p> <ul style="list-style-type: none"> Petrol Chainsaw Electric Chainsaw Chain Sharpening Machine <p>Engines and Water Pumps</p> <ul style="list-style-type: none"> Engine –Diesel-(Horizontal) Engine –Diesel(Vertical) Engine-Kerosene Water Pump with Petrol Engine Water Pump with Kerosene Engine Water Pump with Diesel Engine <p>Hand Tools</p> <ul style="list-style-type: none"> Secateurs Folding Saw Garden Rake Garden Shovel Hedge Shear Lopper Telescopic Hedge Shear Telescopic Lopping Shear Tree Pruner Telescopic Steel Pipe & Fruit Picker Bag Sheep Shear <p>Garden Tools</p> <ul style="list-style-type: none"> Electric Pressure Washer Hedge Trimmer Lawn Mower (Electric, Petrol & Manual) Leaf Blower 	<p>Cultivators and Accessories</p> <ul style="list-style-type: none"> Petrol and Diesel <p>Sprayers and Accessories</p> <ul style="list-style-type: none"> Battery Sprayer Portable Power Sprayer Trolley Sprayer Manual Knapsack Sprayer Manual Pressure Sprayer Rose Cans Hose Crimping Machine HTP Sprayer HTP Delivery Hose HTP Hose Reel HTP Stand HTP Gun / Lance(Brass Rod) Knapsack Power Sprayer Mister / Duster / Granuel Spreader HTP Sprayer Set with Diesel Engine HTP Sprayer Set with Kerosene Engine Fogging Machine <p>Milking Machine</p> <ul style="list-style-type: none"> Wood Shredder Fodder Ensiling Chaff Cutter Fodder Grinder Chaff Cutter Fodder Mini Chaff Cutter <p>Harvester</p> <ul style="list-style-type: none"> Maize Sheller Maize Sheller + Dehusker Maize Combine Harvester Onion Digger Carlotti Italy Tea Leaf Harvester Sugarcane Combine Harvester Sugarcane Leaf Stripper <p>Transplanter and Post Hole Digger</p> <ul style="list-style-type: none"> Paddy Transplanter (2 & 8 Rows) Transplanter-Vegetable & Tobacco Post Hole Digger(4” to 14”Augers)
---	--

Cleaning of fuel filter

Using a piece of wire, or the likes, pull out the fuel filter and wash with clean white kerosene. When it is fouled heavily, replace the filter and also wash the tank inside.

⚠ Use of fire is strictly prohibited

Carbon removal

Remove carbon from the muffler in-/outlet, cylinder and piston. This work requires engine servicing skill and some tools. Consult the dealer or nearest service center.

⚠ CAUTIONS DURING INSPECTION

- Disconnect the ignition plug wires before inspection or adjustment to prevent unexpected start of engine.
- Do not touch the engine immediately after operation to prevent burn.
- Use of fire is strictly prohibited when handling the fuel (petrol).
- Make sure to clean spilled fuel sufficiently before using the engine.
- Do not wash the engine with water.
- Do not change the setting revolution speed carelessly. (Consult your dealer when changing the revolution speed.)

STORAGE

When releasing the engine from operation for more than 30 days, it must be serviced and stored as follows with care to prevent the starting trouble or malfunction due to degeneration of fuel.

1. Drain the fuel from the fuel tank and start to run the engine till it is stopped due to use-up of fuel.
2. Wash the inside of fuel tank and fuel filter with white kerosene.
⚠ Use of fire is strictly prohibited
3. Removing the ignition plug, inject a small quantity of new engine oil through the plughole. After idling slowly for few revolutions operating the recoil starter, install the ignition plug. Pull the recoil starter again and stop it at the position where it is felt heavy.
4. Clean the external surfaces with soft cloth and store it at a dry place free from fires.

NOTE: If the unit is left over without draining fuel, impurities in the fuel could clog the fuel passages such as the carburetor, fuel filter, or others, and cause engine troubles. Make sure to drain the fuel when storing the unit for a long period of time.

⚠ Sufficient care must be taken not to use fires at the vicinity when handling the fuel.

Product	Pole Pruner/ Palm Harvester	KisanKraft Invoice Date	
Brand	KisanKraft	KisanKraft Invoice No.	
Model	<input type="checkbox"/> KK-PP2-8627 <input type="checkbox"/> KK-PH2-215		
WARRANTY PERIOD	6 MONTHS	FOR THE SPECIFIED PERIOD FROM THE DATE OF SALE OR DELIVERY WHICHEVER IS EARLIER.	
Dealer's Invoice Date		Dealer's Invoice No.	
Buyer's Info (Name, Address, Phone, etc.):		Dealer's Stamp (Address, Phone, TIN, etc.):	
Buyer's Sign		Dealer's Sign	

What is covered: KisanKraft Limited and its manufacturers warrant this product to be free from defects in material or workmanship. All parts defective in material and workmanship are covered.

This warranty will only cover defects arising under normal usage.

This warranty is limited to repair or replacement by KisanKraft Limited or its manufacturers at the premises of Authorized Dealers, of such parts as appear to KisanKraft or its manufacturers, upon inspection, to be defective in material and/or workmanship. KisanKraft or its manufacturers make no warranty with respect to trade accessories not manufactured or sold by them.

What is not covered: The *warranty shall become null and void* and neither KisanKraft Limited nor any of its manufacturers, nor its authorized dealers assumes any responsibility, if the failure was caused by the following:

- (1) Operation of product with incorrect fuel or lubricants,
- (2) Incorrect usage of machine or misuse,
- (3) Lack of maintenance,
- (4) Negligence,
- (5) Accident or physical damage,
- (6) Repairs made by unauthorized parties and/or with unauthorized parts,
- (7) Improper set up, adjustments, tampering or altered products.

Note: *The purchase is not contingent upon a product demonstration. The purchaser shall satisfy himself with the product, including any product demonstration or verification of any function, before buying. KisanKraft Limited or its authorized dealers, including online sellers, shall not be liable to give any on-site demonstration after purchase of any of the product.*

This warranty is null & void, if you fail to register the warranty with KisanKraft by sending the KisanKraft Copy with dealer's stamp.

KisanKraft Limited (formerly known as KisanKraft Machine Tools P Ltd)

Important: (1) Normal maintenance and adjustments to the product is the responsibility of the customer. (2) Normal wear and tear is not covered under warranty.

(3) Rubber/plastic parts and consumables such as blades, clutch and clutch-bell, spark-plugs, nylon line, air-filters, fuel-filters, oil seals etc. are not covered under the warranty.

No Warranty On Electrical Motor / Electrical Parts / Battery Etc.

Incidental / Consequential Loss: KisanKraft Limited or its manufacturers will not be liable for general damages, including bodily injuries, or for incidental or consequential damages including, but not limited to, loss of use, loss of profits, loss of production, expense of substitute equipment or other commercial loss or damage.

Limitation of Liability: This limited warranty is in lieu of all other express warranties, obligations, or liabilities. Any implied warranties, obligations or liabilities, including, but not limited to, any implied warranty of merchantability shall be limited in duration to the applicable warranty period. Any action for breach of any warranty hereunder, including, but not limited to, any implied warranty of merchantability must be brought within the applicable warranty period.

Modifications of Warranty: No agent, representative, dealer, or employee of KisanKraft Limited or any of its manufacturers has the authority to increase or alter the obligations of this warranty.

Assignment / Transfer of warranty: The warranty cannot be assigned and shall not transfer if the product is resold by the first buyer. The above warranties are extended to the first end user (original purchaser), and no warranty is made, nor authorized to be made assignable on resale by the first end user.

What you must do to obtain limited warranty service: To obtain performance of any obligation under this warranty for failure during the applicable warranty period, deliver the defective product, to the nearest Authorized Dealer. KisanKraft Limited, its manufacturers and its dealers reserve the right to inspect the claimed defective part(s) to determine if the malfunction is the result of a defect covered by this warranty. Please note that the decision of KisanKraft Limited with respect to any warranty claim is final.

Receipt is required for availing warranty services

Jurisdiction: All disputes are subject to Bangalore court's jurisdiction.

Our Products	♦Chainsaws♦Brush Cutters and Accessories♦Harvesters♦ ♦Engines and Water Pumps♦Hand Tools♦Garden Tools♦ ♦Cultivators and Accessories♦Sprayers and Accessories♦ ♦Transplanter and Post Hole Digger ♦Milking Machines♦
---------------------	--

This warranty is null & void, if you fail to register the warranty with KisanKraft by sending the KisanKraft Copy with dealer's stamp.

KisanKraft Limited (formerly known as KisanKraft Machine Tools P Ltd)

🌐: www.kisankraft.com ✉: info@kisankraft.com ☎: +91.80. 22178200

INSPECTION AND SERVICE

Table of regular inspections

Item \ Time	Before Each Operation	At Every 50-hours	At Every 100-hours	2 Years
Inspection and retightening of bolts, nuts	✓			
Inspection of fuel leakage	✓			
Inspection, cleaning of air cleaner	✓			
Cleaning at cooling air inlet, cooling fin and around muffler	✓			
Inspection, cleaning of ignition plug		✓		
Inspection, cleaning of fuel filter		✓		
Removal of carbon from muffler, cylinder		✓		
Cleaning of spark arrestor		✓		
Replacement of ignition plug			✓	
Replacement of fuel piping (fuel pipe and grommet)				✓

INSPECTION AND SERVICE BEFORE EACH OPERATION

Cleaning of air cleaner

Wash the element with white kerosene and then immerse it in engine oil. Squeeze it tightly with single hand.



⚠ Use of fire is strictly prohibited

Cleaning and service at respective sections

- Clean thoroughly around the muffler.
- Clean the cooling fins and the cooling air inlet.
- Inspect and retighten bolts and nuts.
- Inspect the fuel leakage.

INSPECTION AND SERVICE AT EVERY 50-HOUR

Cleaning and adjustment of ignition plug

After removing carbon accumulated on the electrodes and the insulator, adjust the clearance between the electrodes at 0.6 ~ 0.7 mm

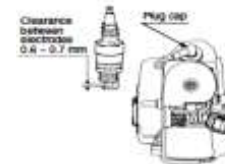

⚠ When mounting the plug cap, push it in securely

3. In case with the high speed fuel adjustment screw
- Right turns: Decrease the thickness of fuel.
 - Left turns: Increase the thickness of fuel.

 Fuel adjustment for the carburetor is completed at the optimum condition before shipping from the factory. When it is necessary to adjust, consult your dealer.

 Do not decrease the thickness of fuel too much. (It could result in the seizure trouble of engine.)

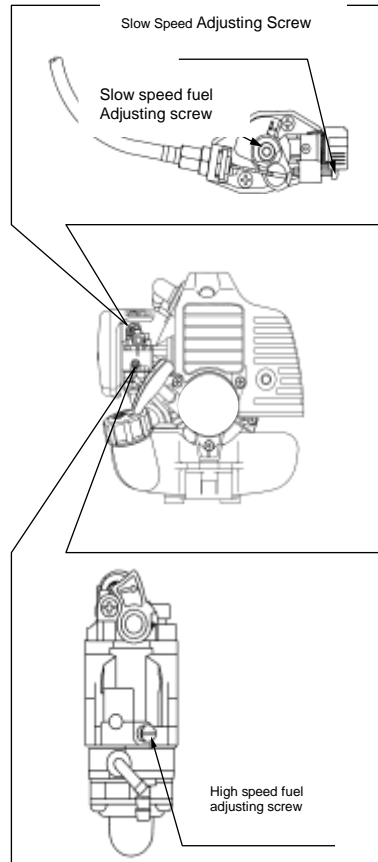

Before Getting Started

Before using the machine please read this operator's manual carefully, operate the machine correctly and engage in your task with safety. Please preserve this manual properly so that it can provide you with information whenever necessary.

Application



Pole Pruner: This is used to prune (trim) tall branches and stems which are hard to reach. This is a power tool driven by a 2-stroke petrol engine and has a telescopic pole which is extendable. It uses a small chainsaw as a cutting head.







Palm Harvester: This is specially designed to harvest palm fruit bunches and pruning fronds. Our Palm Harvester is a power tool having either a chisel or saw cutting head as attachment. It is driven by a 2-stroke petrol engine and has a telescopic pole which is extendable. Use of this harvester can increase the productivity by 3 times when compared to manual sickle by reducing manpower and operational expenditure. This harvester is light in weight and have a stiff pole for easier handling and better control especially when harvesting tall palms. Other significant features of this machine include its swift and smooth harvesting, durability, less vibration and low maintenance.

Note: Any other purpose not specified and permitted in this manual may damage device and cause serious injury to the user. Do not use this device to cut thorn, shrub or bush. The manufacturer shall not be responsible for damage caused by wrong operation.

Safety Symbols on the Machine

Important: Some of the following symbols may be used on your tool. Please study them and learn their meaning. Proper interpretation of these symbols will allow you to operate the tool better and more safely.

SYMBOLS	NAME	EXPLANATION
	Safety Alert Symbol	Indicates danger, warning or caution. It means attention!!! Your safety is involved.
	Read Your Operator's Manual	Your manual contains special messages to bring attention to potential safety concerns as well as operating and servicing information. Please read all the information carefully to ensure satisfaction and safe use.
	Appropriate ear, eye, and head protection must be worn	Depiction of human head (front view) wearing ear, eye, and head protective equipment.

	gloves	Wear non-slip, heavy-duty gloves.
	boots	Wear non-slip safety footwear when using this equipment.
	Keep bystanders away	Keep all bystanders at least 15m (50 ft.) away. Keep the machine a sufficient distance away from electrical power lines.
	No Smoking	Do not smoke when mixing fuel or filling fuel tank.
	Oil	Use 2-stroke oil for air cooled engines.
	Beware of chain saw kickback and avoid contact with bar tip	Movement of chain saw upward from log
<p>WARNING  DANGER: The engine exhaust from this product contains chemicals which may cause cancer, birth defects or other reproductive harm.</p>		

Note: Specifications, descriptions and illustrative material in this manual are as accurate as known at the time of publication, but are subject to change without notice. Illustrations may include optional equipment and accessories, and may not include all standard equipment

Safety Instructions

Proper and safety precautions must be observed. Like all power equipment this unit must be handled carefully. **DO NOT EXPOSE YOURSELF OR OTHERS TO DANGER.** Follow these general rules. Do not permit others to use this machine unless they are thoroughly responsible and have read, and understand the machine manual and are trained in its operation



Please pay attention to safety instructions when using machine.

1. Before you use this machine, check all the operating parts, to ensure safe use. You shall practice to use this machine and let skilled person or professional instruct its functions, operational mode and operating skill who shall ensure you

- Stop the engine immediately if it has been discovered any leakage of fuel or gas from the carburetor, muffler, fuel tank, crankcase, cylinder or mating face at respective sections. (Contact a dealer or service center for repair.)
- Do not change the setting revolution speed of engine unnecessarily.
- Be careful not to touch highly heated muffler or sections on the engine to avoid possible risk of burn.
- Do not operate the engine while withered grasses, leaves or other inflammable substances are sticking in or around the muffler cover.
- Do not touch the ignition plug cap or high-voltage cord during operation. (There is risk of electric shock or physical injury.)
- Do not operate the engine with the muffler or air cleaner cover removed

ADJUSTING THE CARBURETOR

 Engine revolution speed is adjusted at the optimum condition before shipping from the factory. It should be adjusted only when it fails to operate properly. (Consult your dealer when adjustment is necessary.)

1. Use the slow speed adjusting screw to adjust the slow speed revolutions.
 - Right turns: Increase the revolution speed.
 - Left turns: Slow down the revolution speed.



Increasing the slow revolution excessively causes the driven equipment unable to stop even if the throttle lever is returned. The revolution speed should not be increased excessively.

2. In case with the slow speed fuel adjusting screw Normal position is where it is returned by one turn from the fully closed position (right turn).
 - Right turns: Increase the thickness of fuel.
 - Left turns: Decrease the thickness of fuel.

- Turn the engine switch to the "OFF" position. (Switch position may vary depending on the specifications. Refer to the instruction manual of driven equipment.)
In chase of a push button type switch, keep pressing the push button till the engine stops completely.
 - Replenish the fuel before using up completely. It will make easier at the next starting.
 - When there is no subsequent work, drain the fuel from the fuel tank and restart the engine to use up the fuel remaining in the carburetor.

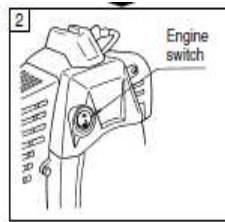

CAUTION

- Place the engine at a horizontal position when the driven equipment is not used at the rest time, or others, in summer season. (If the tank is tilted as much as the inside of fuel cap is submerged in the fuel, the fuel may leak.)
- Do not touch the engine body, especially the muffler, during or immediately after stopping the operation. (There is risk of burn.)

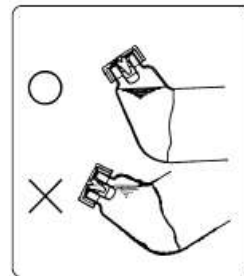

PRECAUTIONS DURING OPERATION

- After starting the engine, set the throttle lever at the slow speed position and warm up the engine for approx. 2~3 minute. As the engine warms up, the engine will be accelerated smoothly.
- Do not attempt to raise the engine speed abruptly immediately after the start because the lubrication oil may not be distributed yet all over the engine.
- If the throttle lever is turned to the fully opened position, the revolution speed picks up to a considerably higher level, which could not only shorten the life of engine but also cause trouble. It should be avoided to race the engine at high speed under no load condition or raise the speed unnecessarily.
- Before starting operation, make sure to inspect the engine in accordance with the "Inspection before starting the engine".
- Do not operate the engine at the indoor or a place with poor ventilation. (Exhaust gas contains odorless and harmful carbon monoxide.)
- Do not insert in or approach hands or foot at the moving or rotating sections.

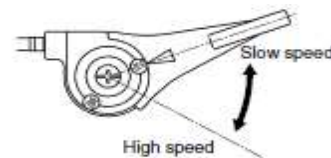

can immediately stop the device in case of an emergency. Using this machine against the instructions given may result in serious injury.

2. **Wear proper protective suit:**

- Put on protection goggles and hearing protection devices and safety helmet.
- Wear your protection gloves
- Wear safety shoes with strong soles.



- Dress properly, do not wear loose clothing or jewellery that could become caught in moving parts of the unit. Safe, sturdy, nonskid footwear should always be worn. Long hair should be tied back. It is recommended that legs and feet be covered to protect from flying debris during operation.
- Inspect the entire machine for loose parts (nuts, bolts, screws, etc.) and any damage. Repair or replace as necessary before using the machine.
- DO NOT USE any attachment with this power head other than the ones recommended by our company. Serious injury to the operator or bystanders could result as well as damage to the machine.
- Keep the handles free from oil and fuel.
- Always use proper handles and shoulder strap when cutting.
- Do not smoke while mixing fuel or filling tank.
- Do not mix fuel in an enclosed room or near open flames. Assure adequate ventilation.
- Always mix and store the fuel in a properly marked container that is approved by local codes and ordinances for such usage.
- Never remove the fuel tank cap while the engine is running.
- Need to keep the machine in good working condition, as well as the cutting attachment and the cutting attachment guard.
- Never use of non-conformant replacement components, or the removal or modification of safety components.
- Never start or run the engage inside a closed room or building. Fumes from the exhaust contain dangerous carbon monoxide.
- Never attempt to make engine adjustments while the unit is running and strapped to the operator. Always make engine adjustments with the unit resting on a flat, clear surface.
- Do not use the unit if it is damaged or poorly adjusted. Never remove the machine's guard. Serious injury to the operator or bystanders could result as well as damage to the machine.
- Inspect the area to be cut and remove all debris that could become entangled in the nylon cutting head. Also remove any objects that the unit may throw during cutting.
- Keep all bystanders, especially children and pets, from the work area, at least 15 METER (50 FEET) from the operating area.
- Never leave the machine unattended.
- Do not use this unit for any job other than those for which it is intended as described in this manual.
- Do not overreach. Keep proper footing and balance at all times. Do not run the unit while standing on a ladder or on any other unstable footing location.

22. Do not use the unit when you are tired, ill or under the influence of medication, drugs or alcohol.
23. FOLLOW INSTRUCTION FOR CHANGING ACCESSORIES.
 - Do not store in a closed area where fuel vapors can reach an open flame from hot water heaters, heaters, furnaces, etc. Store in a locked, well ventilated area only.
 - Ensure safe and proper performance of your product. Use genuine spare parts provided by our company.
 - The use of any other accessories or attachments may cause a potential hazard or injury to the user, damage to the machine and void this warranty.
24. Clean the machine completely, especially, the fuel tank, its surroundings, and the air cleaner.
25. When refueling, be sure to stop the engine and confirm that it is cooled down. Never refuel when the engine is running or hot. When petrol spills, be sure to wipe it up completely and properly dispose of those materials before starting the engine.
26. Whenever approaching an operator of the machine, carefully call his attention and confirm that the operator stops the engine. Be careful not to distract the operator which can cause an unsafe situation.
27. Pay attention to loosening and overheating of parts. If there is any abnormality of the machine, stop operation immediately and check the machine carefully. If necessary, have the machine serviced by an authorized dealer. Never continue to operate a machine which may be malfunctioning.
28. In start-up or during operation of the engine, never touch hot parts such as the muffler, the high voltage wire or the spark plug.
29. This power tool should be carried only in a horizontal position. Grip the shaft in a manner that the machine is balanced horizontally. Keep the hot muffler away from your body and the cutting attachment behind you. Accidental acceleration of the engine can cause the chain to rotate and cause serious injuries.

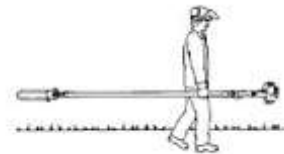

30. Always switch off the engine and fit the scabbard over the cutting attachment before transporting the power tool over long distances. When transporting it in a vehicle, properly secure it to prevent turnover, fuel spillage and damage to the unit.
31. After the engine has stopped, the muffler is still hot. Never place the machine in any places where there are flammable materials (dry grass, etc.), combustible gases or combustible liquids.
32. Pay special attention to operation in the rain or just after the rain as the ground may be slippery.
33. If you slip or fall to the ground or into a hole, release the throttle lever immediately.
34. Be careful not to drop the machine or hit it against obstacles.
35. Before proceeding to adjust or repair the machine, be sure to stop the engine and detach the spark plug cap from the spark plug.
36. When the machine is placed in storage for a long time, drain fuel from the fuel tank and carburetor, clean the parts, move the machine to a safe place and confirm that the engine is cooled down.

6. If you move the throttle lever to the high-speed side a little after the engine has started, the starter lever returns to the operating position. Continue the warm-up operation for 2 to 3 minutes in this condition. Observing the condition of the engine, move the throttle lever to a desired engine speed.

START

⚠ CAUTION

- Before starting the engine, confirm that the area of radius 15 m around the engine is completely evacuated.
- Do not operate the engine when any flammable material (petrol, volatile chemicals, or others) is present around it.
- Driven equipment may start simultaneously with the start of engine. Carefully read the instruction manual of the equipment and start the engine carefully.
- When a class FC oil is used, a larger resistance may be felt when pulling the recoil starter grip under low temperature condition or at the initial operation at the next season. This is related to the characteristic of the oil and there is no problem on the engine. Once started, it will return to the normal condition

Concerning New Start System

It can start even if it is pulled slower than normal.

- If the rope is pulled (vigorously) till it will not come out any more, it could damage the recoil mechanism.
- Do not disassemble the recoil. It is dangerous to disassemble the inside of recoil. (Consult your dealer when it is necessary to replace related parts.)
- If the decompression slot of cylinder is clogged, the engine may start slower than normal. Clean the slot to restore the normal condition.

STOP

1. Set the throttle lever at the slow speed position.

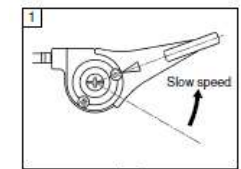

START (STARTER LEVER TYPE UNIT)

1. Turn the engine switch to the "ON" side.

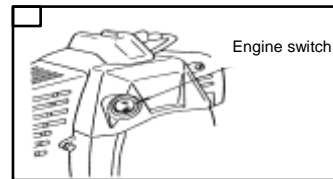

2. Set the throttle lever at the slowest speed position.

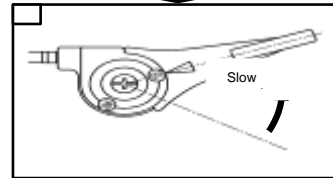

3. Push the priming button repeatedly with finger till it hits the top. (More than 10 times)
Pressing the priming button is necessary to prime the fuel to facilitate the start-up. Since any excess amount of primed fuel returns to the tank, there is no problem of over-priming. Prime the fuel rather more than sufficiently to avoid starting trouble.

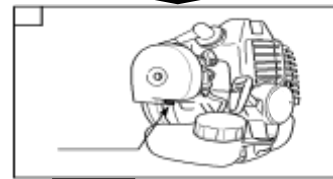

4. Turn down the starter lever of carburetor to set it at the start position.
It is not necessary to operate the starter lever when the engine is warmed up (For about 15 minutes after stopping the engine.)
(To be left in the operating position)
Depending on specifications, the starter lever may be provided at the throttle wire side.

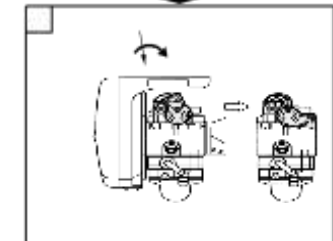

5. While holding down the engine firmly, grasp the recoil starter grip and pull vigorously

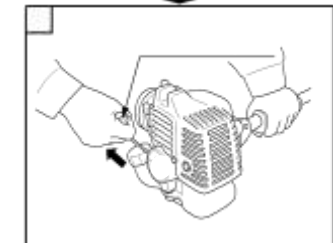

CAUTION:

- a) When the engine stops on the way after starting, or
- b) When the engine fails to start after trying the recoil operation for 7 to 8 times.

Return the starter lever to the operating position and try the recoil operation.

37. Make periodic inspections to assure safe and efficient operation. For a thorough inspection of your machine, please contact a dealer.

38. Keep the machine away from fire or spark.



39. It is believed that a condition called Raynaud's phenomenon, which affects the fingers of certain individuals may be brought about by exposure to vibration and cold. Exposure to vibration and cold may cause tingling and burning sensations followed by loss of color and numbness in the fingers. The following precautions are strongly recommended because the minimum exposure which might trigger the ailment is unknown.

40. Check for fuel leakage while refueling and during operation. If fuel leakage is found, do not start or run the engine until the leak is fixed and any spilled fuel has been wiped away. Take care not to get fuel on your clothing. If this happens, change your clothing immediately.



41. It is needed for daily inspection before use and after dropping or other impacts in order to identify any significant damage or defects

42. Unit vibrations can cause an improperly tightened fuel filler cap to loosen or come off and spill quantities of fuel. In order to reduce the risk of fuel spillage and fire, tighten the fuel filler cap by hand as securely as possible.



43. To reduce the risk of fire and burn injuries, start the engine at least 10 feet (3 m) from the fueling spot, outdoors only. Start and operate your machine without assistance. For specific starting instructions, see the appropriate section of your manual. Proper starting methods reduce the risk of injury. Place the machine on firm ground or other solid surface in an open area or, in the alternative, as shown in the above picture. Maintain good balance and secure footing.



44. Always hold the unit firmly with both hands on the handles while you are working. Wrap your fingers and thumbs around the handles. Place your left hand on the shaft and your right hand on rear grip and throttle trigger. Left-handers should follow these instructions, too. Keep your hands in this position to have your machine under control at all times.



45. Never attempt to operate your power tool with one hand. Loss of control of the power tool resulting in serious or fatal injury may result.

46. Danger! Your power tool is not insulated against electric shock. To reduce the risk of electrocution, never operate this power tool in the vicinity of any wires or cables (power, etc.) which may be carrying electric current.



47. The power tools are equipped with a catalytic converter, which is designed to reduce the exhaust emissions of the engine by a chemical process in the muffler. Due to this process, the muffler does not cool down as rapidly as conventional mufflers when the engine returns to idle or is shut off. To reduce the risk of fire and burn injuries, the following specific safety precautions must be observed.



48. To reduce the risk of severe or even fatal injury from falling objects do not cut vertically above your body. Hold the pole pruner at an angle of not more than 60° from the horizontal level (see picture). Objects may fall in unexpected directions.

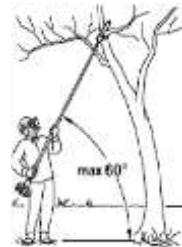

Do not stand directly underneath the limb being cut!

49. Kickback may occur when the moving saw chain near the upper quadrant of the bar nose contacts a solid object or is pinched. The reaction of the cutting force of the chain causes a rotational force on the chainsaw in the direction opposite to the chain movement. This may cause the bar to move upward.

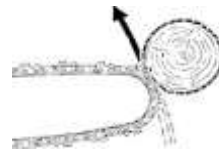

50. **To Avoid Kickback:** The best protection from kickback is to avoid kickback situations:

- Be aware of the location of the guide bar nose at all times.
- Never let the nose of the guide bar contact any object. Do not cut limbs with the nose of the guide bar. Be especially careful near wire fences and when cutting small, tough limbs, which may easily catch the chain.
- Cut only one limb at a time.

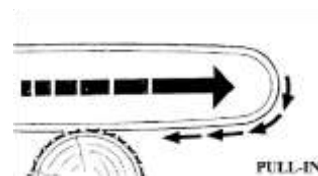

51. **Pull-in:** Pull-in occurs when the chain on the bottom of the bar is suddenly stopped when it is pinched, caught or encounters a foreign object in the wood. The reaction of the chain pulls the saw forward. Pull-in frequently occurs when the chain is not rotating at full speed before it contacts the wood.



OPERATION INSTRUCTIONS

Methods of starting & stopping the engine

START (CHOKE TYPE UNIT):

1. Turn the engine switch to the "ON" side.
2. Set the throttle lever at the slow speed position.
3. Push the priming button repeatedly with finger till it hits the top. (More than 10 times) Pressing the priming button is necessary to prime the fuel to facilitate the start-up. Since any excess amount of primed fuel returns to the tank, there is no problem of over-priming. Prime the fuel rather more than sufficiently to avoid starting trouble.
4. Turn the choke lever to the fully closed position (at the  Mark). When sufficient fuel is retained and the engine is warm, set the choke lever at the fully opened position (at the  mark).
5. While holding down the engine firmly, grasp the recoil starter grip and pull vigorously
6. When the engine has started, return the choke lever gradually to the fully opened position (at the  Mark). If only exploding sounds are heard, but it does not start, return the choke lever to the fully closed position and pull the starter grip vigorously once again.

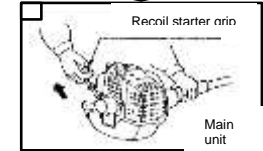
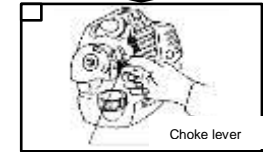
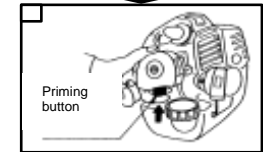
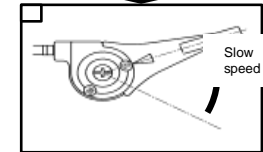
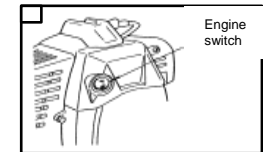

INSPECTION OF RESPECTIVE SECTIONS:

Make sure to inspect these sections before operating the engine.

Inspection of fuel

- Is sufficient quantity of oil reserved?
- Is not the fuel degenerated?
- Use the proper fuel referring to the "Fuel" section.

CAUTION

- Sufficient care must be taken on the fire not only when replenishing but also handling fuel. It could cause fire or explosion.
- Securely close the oil tank cap. Fuel may leak if the cap is tightened aslant. It will never leak if the cap is tightened properly. (Excluding: TL tank cap breather type)

Inspection of clogging

- Check the cooling fins, around the muffler and cooling air inlet for trash or withered grasses trapped.
- Remove them if necessary

Inspection of air cleaner

- Is not fouled the air cleaner element?
- When the element is fouled or it is not impregnated with oil, inspect and service it in accordance with "Inspection and servicing before each operation"

Inspection of screws and nuts

- Check respective sections for loose or missing screws or nuts.
- Service them if necessary.

Inspection of fuel pipes

- Check for cracks or fissures on the fuel pipe and grommet, disconnection or fuel leakage from joints on the fuel tank and carburetor.

CAUTION

Cracks, fissures or disconnection from joints could cause fire or explosion by leaked fuel. Service or replace damaged fuel pipe and grommet.

To Avoid Pull-in: 1. Be alert to forces or situations that may cause material to pinch the chain at the bottom of the bar. 2. Always start a cut with the chain rotating at full speed.

52. **Pushback:** Pushback occurs when the chain on the top of the bar is suddenly stopped when it is pinched, caught or encounters a foreign object in the wood. The reaction of the chain may drive the saw rapidly straight back toward the operator. Pushback frequently occurs when the top of the bar is used for cutting.

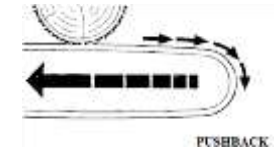
**To Avoid Pushback:**

- Be alert to forces or situations that may cause material to pinch the chain at the top of the bar.
 - Do not cut more than one limb at a time.
 - Do not twist the bar when withdrawing it from an under buck cut because the chain can pinch.
53. Keep the chain, bar and sprocket clean; replace worn sprockets or chains. Keep the chain sharp. You can spot a dull chain when easy-to-cut wood becomes hard to cut or burn marks appear on the wood. Keep chain at proper tension. Tighten all nuts, bolts and screws except the carburetor adjustment screws after each use. For maintenance items please also refer to the maintenance chart in this manual. Do not clean your machine with a pressure washer. The solid jet of water may damage parts of the machine. Store the power tool in a dry and high or locked location out of reach of children. Before storing for longer than a few days, always empty the fuel tank. See chapter "Storing the machine" in this manual. Store fuel and chain oil in approved and properly labeled safety-type canisters only. Take care when handling petrol! Avoid direct contact with the skin and avoid inhaling fuel vapor!
54. **Noise and Vibration**
- The running at low speed can reduce the noise and quiver.
 - In order to reduce noise, the pole saw should be operated at an open environment.
 - The vibration can be lowered if the handle is grasped firmly.
 - In order to avoid disturbing others, the machine should be operated in daytime.
 - Dress personal protective equipment, such as gloves and ear protection during the operation.
 - The machine is not for professional work and not for long time operation.
 - In order to keep the user's fit and prolong the machine's life, please do not work more than 2 hours in a whole day and don't keep working more than 10 minutes and often changing working positions.

Main Parts

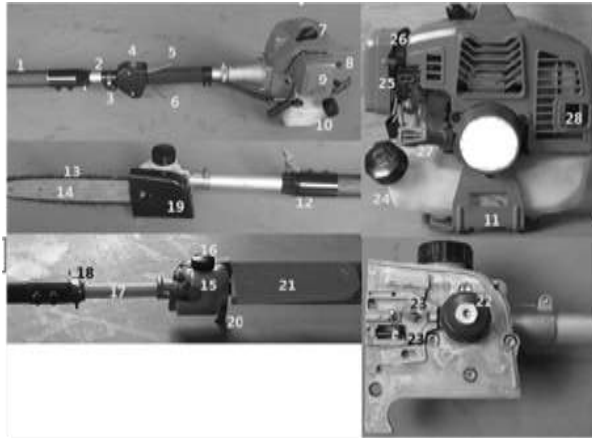

- | | |
|-----------------------------|---|
| 1. Handle Hose | 15. Oil Tank |
| 2. Fixed Drive Tube | 16. Oil Filler Cap |
| 3. Carrying Ring | 17. Telescopic Drive Tube (Shaft) |
| 4. Slide Control | 18. Clamp Screw |
| 5. Throttle Trigger Lockout | 19. Chain Sprocket Cover |
| 6. Throttle Trigger | 20. Hook |
| 7. Spark Plug Boot | 21. Chain Guard (Scabbard) |
| 8. Choke Knob | 22. Chain Sprocket |
| 9. Air Filter Cover | 23. Chain Tensioner |
| 10. Fuel Tank | 24. Fuel Filler Cap |
| 11. Machine Support | 25. Carburetor Adjusting Screws |
| 12. Clamp | 26. Fuel Pump |
| 13. Saw Chain | 27. Starter Grip |
| 14. Guide Bar | 28. Muffler (with Spark Arresting Screen) |

Using the Unit

Preparation:

- Wear suitable protective clothing, observe safety precautions.
- Adjust telescoping shaft to the required length.
- Start the engine.
- Put on the shoulder strap.

Cutting Sequence:

To allow branches a free fall, always cut the lower branches first. Prune heavy branches (large diameter) in several controllable pieces.

INSPECTION BEFORE OPERATING THE ENGINE

NOTE: In 2 Stroke engine the petrol and engine oil are mixed and poured together.

FUEL: Use mixed oil of ordinary regular petrol for vehicle and special 2-cycle engine oil with the proportion as shown by the following table.

Mixing ratio (Volumetric ratio):

Petrol : 2-cycle engine oil
40: 1

- Do not use degenerated oil (with sour smell).
- (It could cause engine trouble such as the starting error, insufficient output, etc.)
- Make sure to clean spilled fuel. It could foul clothes or cause fire.
- Do not use 4-cycle engine oil. (It could cause fouled plug, bound piston ring, clogged muffler, or other problem.)
- Take care while handling petrol. (As there is a risk of explosion.)

ADJUSTMENT OF THROTTLE WIRE:

Adjust the play on the throttle wire to 0.5 ~ 1.0 mm.

LARGER PLAY

- It could cause the starting trouble.
- Revolution speed could rise unexpectedly when the external wire of throttle wire comes off from the position.

NO PLAY

- Driven equipment may fail to stop even if the throttle lever is returned.

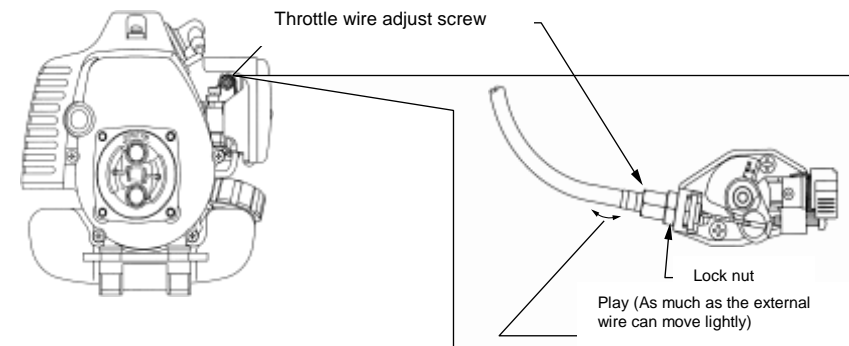

- Do not operate the engine when grass, leaves or inflammable substances are sticking in or around the muffler.
- Do not touch parts of muffler or engine at high temperatures. (There is risk of burns.)
- Do not touch the ignition plug or high-voltage cord during operation. (There is risk of electric shock or physical injury.)
- Make sure to stop the engine whenever the work is interrupted or moving the engine to another place.
- Do not operate the engine alone. (It must be connected to the driven equipment when it is operated).
- Check frequently the parts used on the fuel line for cracks or leakage, and replace them if necessary.
- Remove dirt, grass or other trash from the cooling fins and the cooling air inlet. (Make sure to stop the engine and the driven equipment before the cleaning.)
- Make sure to use always new petrol. (Old petrol may cause sticky substance adhering at the inside of carburetor causing trouble in operation.)
- Before starting the engine, confirm that the area of radius 15 m around it is evacuated and no tank filled with fuel, or others are not left over.
- Use only genuine parts supplied from the manufacturer. Use of parts other than the genuine parts could cause engine trouble or premature abrasion.

Note: Important safety items quoted in this manual do not necessarily cover all situations or conditions that could occur. Although sufficient care has been taken to assure the safety of the engine, operators or service personnel must observe necessary precautions to operate it safely and protect themselves from possible dangers.

 Never stand directly underneath the branch you are cutting – be wary of falling branches.
Note that a branch may spring back at you after it hits the ground – risk of injury.

Disposal:

Do not throw cuttings into the garbage can – they can be composted.

Working Techniques:

Hold the control handle with your right hand, and the shaft with your left hand. Your left arm should be extended to the most comfortable position. Always hold the shaft with your left hand in the area of the handle hose. The shaft should always be held at an angle of 60° or less. The least tiring working position is a tool angle of 60°. Any lesser angle may be used to suit the situation concerned.

WARNING!

When you use the machine, if the saw chain is locked by the branch, you must move over the saw and then saw the branch over again.



Cross-cut:

To avoid pinching the bar in the cut, position the cutting attachment with the hook against the branch and then perform the cross-cut from the top downwards.



Relieving cut:

To avoid tearing the bark on thick branches, always start by performing a relieving cut (1) on the underside of the branch:

- To do this, apply the cutting attachment and pull it across the bottom of the branch in an arc as far as the bar nose.
- The hook against the branch and then perform the crosscut.

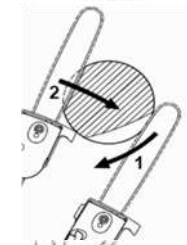

Flushing-cutting thick branches:

If branch diameter is more than 4 in (10 cm), first perform undercut (3) and then cross-cut at a distance of about 8 in. /20 cm (A) from the final cut. Then carry out the flush-cut (4), starting with a relieving cut and finishing with a cross-cut.

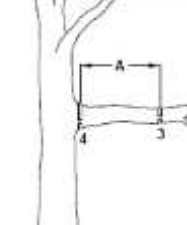

Cutting above obstacles:

The unit's long reach makes it possible to prune branches that are overhanging obstacles, such as rivers or lakes. The tool angle in this case depends on the position of the branch.



Cutting from a lift bucket:

The unit's long reach enables cutting to be performed next to the trunk without the risk of the lift bucket damaging other branches. The tool angle in this case depends on the position of the branch.



Mounting the Bar and Chain

Removing the chain sprocket cover:

- Unscrew the nut and remove the cover.
- Turn the screw (1) counterclockwise until the tensioner slide (2) butts against the left end of the housing slot, then back it off 5 full turns.

⚠ Guide-bar and chain adjustments can only be made with the engine stopped.

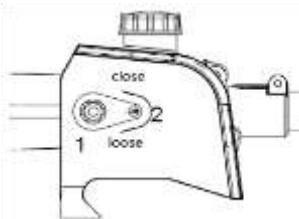

Fitting the chain:

⚠ Wear work gloves to protect your hands from the sharp cutters.
Fit the chain – start at the bar nose.
Fit the guide bar over the screw (3) and engage peg of tensioner slide in the hole (4) – place the chain over the sprocket (5) at the same time.
Turn the tensioning screw (1) clockwise until there is very little chain sag on the underside of the bar – and the drive link tangs are engaged in the bar groove.
Refit the cover and screw on the nut finger tight and refer to "Tensioning the Saw Chain".

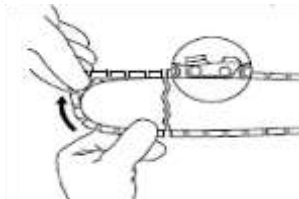

2 Stroke Petrol Engine- Manual



BEFORE GETTING STARTED

This manual describes various cautions necessary to operate the engine properly. Before starting the engine, read the manual and understand the proper method of use. (Improper use of the engine could result in accident or injury.)







Use the engine after reading and understanding also the manual of equipment driven by the engine.

Keep the manual at a safe place where you can refer whenever needed.

SAFETY INSTRUCTIONS

	You have to observe the descriptions indicated with this mark because they contain very important information to assure the safety
--	--

- No person who does not understand the content of this manual should be allowed to operate the engine.
- Engine should not be operated indoors or in places with poor ventilation. (Exhaust gas contains odorless and harmful carbon monoxide.)
- Do not insert in or approach hands or foot near the moving or revolving sections.
- Do not store, spill or use petrol at the vicinity of fire, stove, furnace or devices using the pilot flame or sparks like water heater or others. (There is risk of explosion.)
- Do not refill the fuel indoors or at a place not well ventilated.
- Do not smoke while filling the fuel.
- Do not remove the fuel tank cap or refill the fuel while the engine is still running or immediately after operation when the engine is still hot. (Wait for more than 2 minutes after terminating the operation before refilling the fuel.)
- Do not operate the engine when petrol has spilled, smell of petrol is felt as there is a risk of explosion.
- Do not adjust the setting engine speed unnecessarily.
- Do not check sparks while the ignition plug is removed.
- Do not operate the engine with the muffler or air cleaner cover removed. (Inspect particularly the muffler at regular intervals for loose mounting screws, breakage or leakage, and repair or replace it if any abnormality is observed.)

Part No		Part Name
GB-17		Screw-Spl-for Blade
GB-18		Connecting Sleeve Ass'y
GB-19		Gear Case Assy
20		Back shaft
21		Front Pipe
22		Front Shaft

Tensioning the Chain:

- Re-tensioning during cutting work:
- Stopping the engine
- Loosen the nut.
- Hold the bar nose up.
- Use a screwdriver to turn the tensioning screw (1) clockwise until the chain fits snugly against the underside of the bar.
- While still holding the bar nose up, tighten down the nut firmly.
- Refer to "Checking Chain Tension". A new chain has to be re-tensioned more often than one that has been in use for some time.
- Check chain tension frequently –refer to "Operating Instructions".

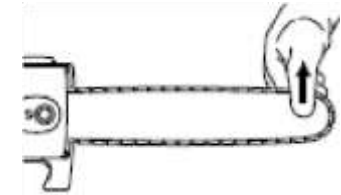

Adjusting the Throttle Cable

A properly adjusted throttle cable is the precondition for correct operation in the full throttle, starting throttle and idle positions.

- Adjust the throttle cable only when the unit is completely and properly assembled.
- Press down the throttle trigger lockout (1) and squeeze the throttle trigger (2) (full throttle) – this sets the throttle cable correctly.

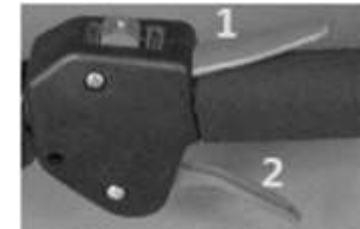

Fuel and Oil Mixture



WARNING!

- Never fill the fuel tank to the very top.
- Never add fuel to the tank in a closed non-ventilated area.
- Do not add fuel to this unit close to an open fire or sparks.

- Be sure to wipe off spilled fuel before attempting to start engine.
- Do not attempt to refuel a hot engine.
- Filling of fuel and oil, especially concerning fire precautions

Fuel used for this model is a mixture of unleaded petrol and approved engine lubricant. When mixing petrol with two-cycle engine oil, use only petrol which contains NO ETHANOL or METHANOL (Types of Alcohol) Use Branded 89 octane or higher unleaded petrol known to be of good quality. This will help to avoid possible damage to engine fuel lines and other engine parts.

MIXTURE RATIO is 40:1

PETROL: OIL	40:1
-------------	------

Fuel mixture at the rate other than 40:1 may cause damage to the engine, Ensure mixture ratio is correct.

Fuel

The engine uses two-stroke fuel, a mixture of petrol and 2-stroke lubricant 40:1.

IMPORTANT

Two-stroke fuel may separate. Shake fuel container thoroughly before each use. Stored fuel ages. Do not mix more fuel than you expect to use within a month.

Fuel and oil mixture

Inspect fuel tank making sure that it is clean and fill with fresh fuel. Use a mixture of 40:1.

Petrol

Use branded 90 octane or higher no lead petrol known to be of good quality.

Storing fuel

Store fuel only in a clean, safe, approved container. Check and follow local ordinances on type and location of storage container.

⚠ CAUTION:

The engine exhaust from this product contains chemicals known to cause cancer, birth defects, or other reproductive harm.

Chain Lubricant

For automatic and reliable lubrication of the chain and guide bar – use only an environmentally compatible quality chain and bar lubricant.

⚠ Biological chain oil must be resistant to aging, since it will otherwise quickly turn to resin. This results in hard deposits that are difficult to remove, especially in the area of the chain drive and chain.

It may even cause the oil pump to seize.

The service life of the chain and guide bar depends on the quality of the lubricant. It is therefore essential to use only a specially formulated chain lubricant.

⚠ Do not use waste oil. Renewed contact with waste oil can cause skin cancer. Moreover, waste oil is environmentally harmful.

⚠ Waste oil does not have the necessary lubricating properties and is unsuitable for chain lubrication.

⚠ A full chain oil tank is sufficient for only half a tankful of fuel. Check the oil level regularly during cutting work. Never allow the oil tank to run dry.







Preparations





- Thoroughly clean the oil filler cap and the area around it to ensure that no dirt falls into the tank.
- Position the machine so that the filler cap is facing up.

Opening the filler cap

The bayonet-type oil tank filler cap with hinged grip can be opened and closed without tools.

- To open the tank, swing the grip to the vertical position.
- Turn the filler cap counterclockwise as far as stop and remove.

Part No		Part Name
GB-11		Bearing Big-Connecting Rod
GB-12		Bearing Small-Connecting Rod
GB-13		Saw Blade
GB-14		Holder- Chisel
GB-15		Chisel
GB-16		Sickle

Part No		Part Name
GB-6		Connecting Rod
GB-7		Pinion
GB-8		Nut Oil Drain
GB-9		Pin 7x11
GB-10		Bearing

Filling up with chain oil

- Filling up with chain oil
- Take care not to spill chain oil while refilling and do not overfill the tank.

Closing the filler cap

To close the oil tank, place the filler cap in position with the grip upright, making sure the recesses are in alignment.

- Turn the filler cap clockwise as far as stop.
- Fold the grip down so that it is flush with the top of the cap.

If the oil level in the tank does not go down, the reason may be a fault in the oil supply system: Check chain lubrication, clean the oilways, contact your dealer for assistance if necessary. We recommend you have servicing and repair work carried out exclusively by our servicing centers.

Checking Chain Lubrication

The saw chain must always throw off a small amount of oil.

 Never operate your saw without chain lubrication. If the chain runs dry, the whole cutting attachment will be irretrievably damaged within a very short time. Always check chain lubrication and the oil level in the tank before starting work. Every new chain has to be broken in for about 2 to 3 minutes. After breaking in the chain, check chain tension and adjust if necessary – see "Checking Chain Tension".

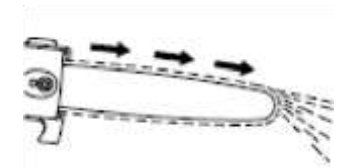

Preparing for Operations

Adjusting the Telescoping Shaft

 Always shut off the engine and fit the chain guard.

- Loosen the screw.
- Adjust shaft to the required length.
- Tighten down the screw firmly.

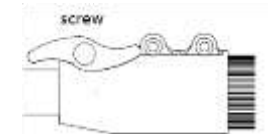

Fitting the Harness

- The type and style of the harness depend on the market.
- Put on the shoulder strap (1).
- Adjust the length of the strap.
- With the power tool attached, the carabiner (2) must be at about the same height as your right hip.



⚠ WARNING! To quickly detach the pole saw from the shoulder strap, pull the quick-release latch tab upward.

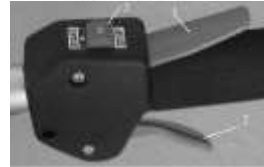

Controls

1. Throttle trigger lockout
2. Throttle
3. Slide control

Starting

- Press down the trigger lockout lever and squeeze the throttle trigger.
- Hold them in that position.
- Move the slide control to START and hold it there.
- Now release the throttle trigger, slide control and trigger lockout in that order. This is the starting throttle position.
- Set the choke knob (4): If the engine is cold and for warm start – also use this position if the engine has been running but is still cold.
- Press the fuel pump bulb (5) at least five times – even if the bulb is already filled with fuel.

Starting method 1:

- Remove the blade scabbard. Check that the chain is not touching the ground or any other obstacles.
- Place the unit on the ground: It must rest securely on the engine support and the hook. If necessary, rest the hook on a raised support (e.g. a branch, mound or something).
- Make sure you have a safe and secure footing.
- Hold the unit with your left hand on the fan housing and press it down firmly – your thumb should be under the fan housing.

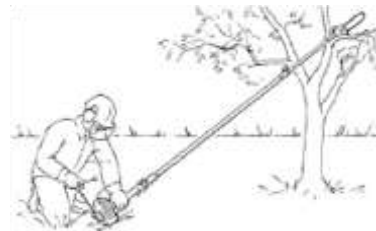

⚠ Check that nobody is standing within the working range of the machine.
Ⓜ Do not stand or kneel on the drive tube. This will bend the drive tube and may result in permanent

Body Parts Diagram & List- KK-PH2-215

Part No		Part Name
GB-1		Gear Case Big
GB-2		Gear Case Small
GB-3		Packing-Gear case
GB-4		Shaft -Blade Fixing
GB-5		Gear With Cam shaft

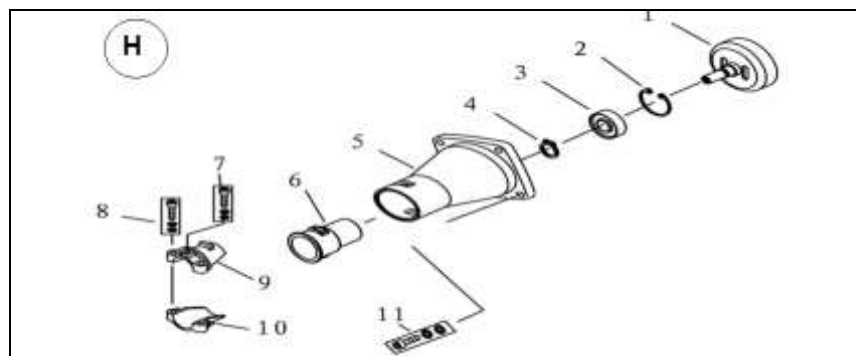

Part. No	Part Name	Part. No	Part Name
B-H	Clutch Comp.	BH-06	Rubber Cover(Linker)
BH-01	Clutch Drum	BH-07	Screw M5X12 (Allen)
BH-02	Stop Ring 35 (Inner)	BH-08	Screw M5X25 (Allen)
BH-03	Bearing 6202-2RZ/PE	BH-09	Clamp A
BH-04	Stop Ring 15(Outer)	BH-10	Clamp B
BH-05	Linker	BH-11	Screw M6X20 (Allen)

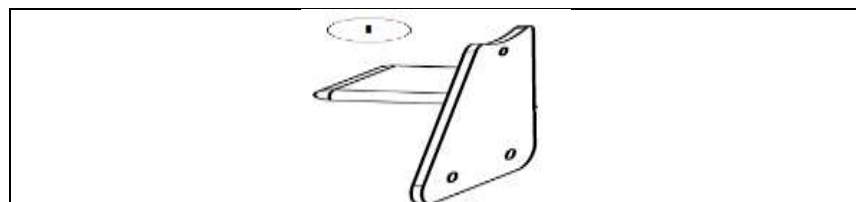

Part. No	Part Name
B-I	Bracket Engine (Small)

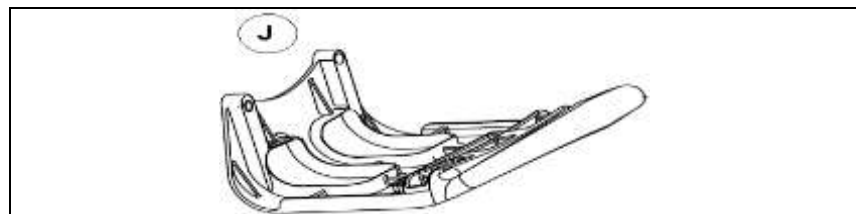

Part. No	Part Name
B-J	Bracket Engine (Big)

Starting method 2:

- Remove the chain guard. Position the shaft on a branch so that it is held by the hook.
- Hold the unit firmly with your left hand on the fan housing - your thumb should be under the fan housing.
- Hold the starter grip with your right hand.
- Pull the starter grip slowly until you feel it engage and then give it a brisk strong pull.
- Do not let the starter grip snap back. Guide it slowly back into the housing so that the starter rope can rewind properly.
- Crank the engine until it begins to fire. After no more than five attempts, turn the choke knob to ☐.
- Continue cranking.



☑ Do not pull out the starter rope all the way - it might otherwise break.

As soon as the engine runs:

⚠ Make sure the carburetor is correctly adjusted. The saw chain must not rotate when the engine is idling.
Your machine is now ready for operation.

Shut off the engine:

⚠ Push the slide control in the direction of the arrow on the stop symbol to STOP.

At very low outside temperatures:

As soon as the engine runs:

- Blip the throttle trigger to disengage the starting throttle position. The slide control moves to the normal run position and the engine settles down to idle speed.
- Open the throttle slightly.
- Warm up the engine for a short period.

If the engine does not start:

Choke knob: If you did not turn the choke knob to ☐ quickly enough after the engine began to fire, the combustion chamber is flooded.

- Turn the choke knob to ☐.
- Set the slide control, lockout lever and throttle trigger to the starting throttle position.
- Start the engine by pulling the starter rope briskly - 10 to 20 pulls may be necessary.

Fuel tank run until completely dry:

- After refueling, press the fuel pump bulb at least five times - even if the bulb is filled with fuel.
- Set the choke knob according to engine temperature.
- Start the engine.

Operating Instructions

During break-in period:

A factory-new machine should not be run at high revs (full throttle off load) for the first three tank fillings. This avoids unnecessary high loads during the break-in period. As all moving parts have to bed in during the break-in period, the frictional resistances in the engine are greater during this period. The engine develops its maximum power after about 5 to 15 tank fillings.

Do not make the mixture leaner to achieve an apparent increase in power – this could damage the engine – see "Adjusting the Carburetor".

- Check chain tension frequently: A new chain has to be re-tensioned more often than one that has been in use for some time.
- Chain cold: Tension is correct when the chain fits snugly against the underside of the bar and can still be pulled along the bar by hand. Re-tension if necessary – see "Tensioning the Saw Chain".
- Chain at operating temperature: The chain stretches and begins to sag. The drive links must not come out of the bar groove – the chain may otherwise jump off the bar. Re-tension the chain – see "Tensioning the Saw Chain".
- After long period of full throttle operation: Allow engine to run for a short while at idle speed so that engine heat can be dissipated by the flow of cooling air. This protects engine-mounted components (ignition, carburetor) from thermal overload.

The chain contracts as it cools down. If it is not slackened off, it can damage the gear shaft and bearings.

After Finishing Work:

- Slacken off the chain if you have re-tensioned it at operating temperature during cutting work.
- Storing your saw for a short period Wait for the engine to cool down. Drain the fuel tank. Store the machine in a dry location. Check the tightness of all accessible screws and nuts (not adjusting screws) at regular intervals and retighten if necessary.
- Storing for a long period See chapter on "Storing the Machine"

Always slacken off the chain after finishing work. The chain contracts as it cools down. If it is not slackened off, it can damage the gear shaft and bearings.

Part. No	Part Name	Part. No	Part Name
B-E	Lever Assy	BE-10	N/A
BE-01	Clamp	BE-11	N/A
BE-02	N/A	BE-12	N/A
BE-03	N/A	BE-13	Stop Switch
BE-04	Spring(Tine)	BE-14	N/A
BE-05	Spring(Safety Lever)	BE-15	N/A
BE-06	Spring(Throttle Lever)	BE-16	N/A
BE-07	N/A	BE-17	Rubber Cover(Thin Pipe)
BE-08	N/A	BE-18	N/A
BE-09	Throttle cable	BE-19	N/A

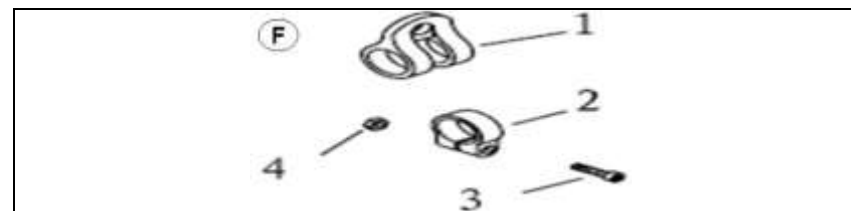

Part. No	Part Name	Part. No	Part Name
B-F	Holder Assy	BF-03	N/A
BF-01	N/A	BF-04	N/A
BF-02	N/A		

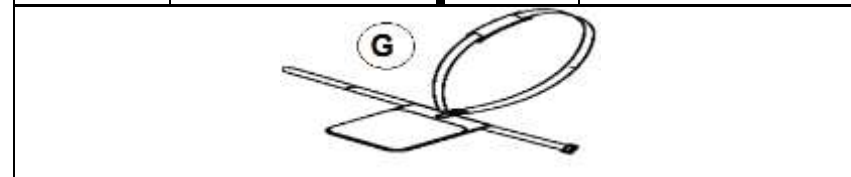

Part. No	Part Name
B-G	Harness Assy

Part No	Part Name	Part No	Part Name
B-C	Connecting Sleeve Assy	BC-02	Handle(Connecting Sleeve)
BC-01	N/A	BC-03	Screw M5X20 (Allen)

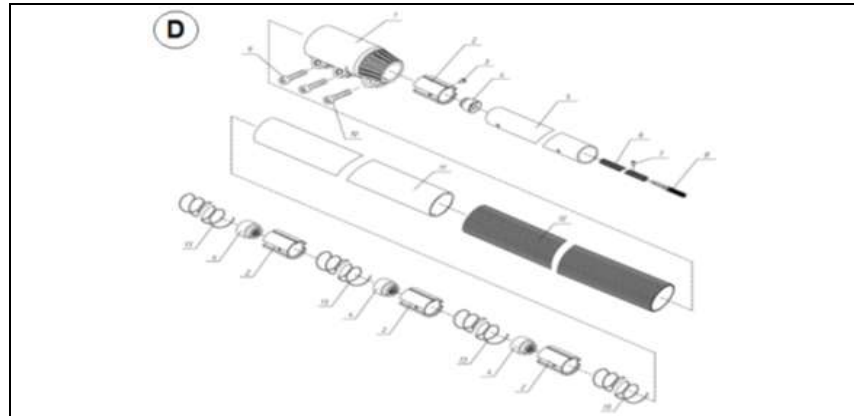

Part. No	Part Name	Part. No	Part Name
B-D	N/A	BD-07	Screw ST2. 9 X 6. 5
BD-01	N/A	BD-08	Joint(Back Shaft)
BD-02	Bearing Assy (Back Shaft)	BD-09	Screw M5X20(Allen)
BD-03	Rivet 4X8 (Back Shaft)	BD-10	Screw M6X20(Allen)
BD-04	Shaft Sleeve (2)	BD-11	Thick Pipe
BD-05	Thin Pipe	BD-12	Rubber Cover (Thick pipe)
BD-06	Back Shaft	BD-13	Spring (Thick pipe)

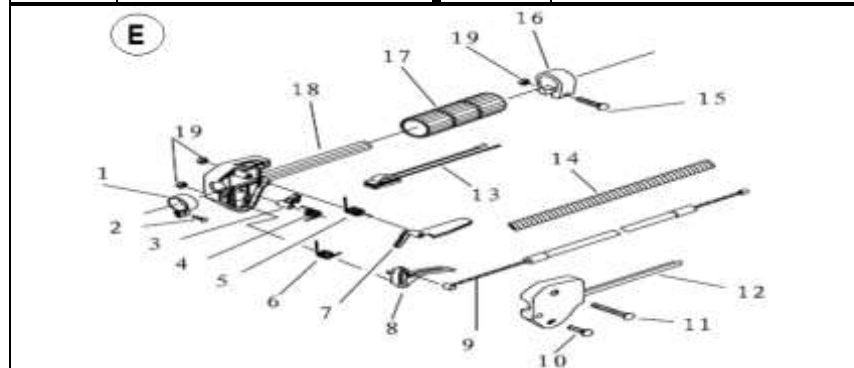

Taking Care of the Guide

- Turn the bar over – every time you sharpen the chain and every time you replace the chain – this helps avoid one-sided wear, especially at the nose and underside of the bar.
- Regularly clean the oil inlet hole (1), the oilway (2) and the bar
If groove depth is less than specified: Replace the guide bar. The drive link tangs will otherwise scrape along the bottom of the groove – the cutters and tie straps will not ride on the bar rails groove (3).
- Measure the groove depth – with the scale on the filing gauge (special accessory) – in the area used most for cutting. If groove depth is less than specified:
- Replace the guide bar. The drive link tangs will otherwise scrape along the bottom of the groove – the cutters and tie straps will not ride on the bar rails.



WARNING! It is routine for checking that the cutting attachment stops turning when the engine idles.

Chain type	Chain pitch	Minimum groove depth
Picco	3/8" P	0.20"(5.0 mm)
Rapid	1/4"	0.16"(4.0 mm)

Engine Management

Cleaning the Air Filter:

If there is a noticeable loss of engine power

- Turn the choke knob to \bar{I}
- Take out the screw (1) and remove the filter cover (2).
- Clean away loose dirt from around the filter.
- Grip the filter element (3) at the cutout (arrow) in the filter housing (4) and remove it.
- Fit a new filter element. As a temporary measure you can knock it out on the palm of your hand or blow it out with compressed air. Do not wash.
- Replace damaged parts. Installing the filter
- Install the filter element in the filter housing and fit the cover.
- Insert the screw and tighten it down firmly.



Adjusting the Carburetor:

The carburetor comes from the factory with a standard setting. This setting provides an optimum fuel-air mixture under most operating conditions. With this carburetor it is only possible to adjust the high speed and low speed screws within fine limits. Standard Setting

- Stopping the engine
- Check chain tension
- Check the air filter and clean or replace as necessary. Check that the throttle cable is properly adjusted - readjust if necessary - see chapter on "Adjusting the Throttle Cable".
- Check the spark arresting screen (not in all versions) and clean or replace as necessary.
- Carefully turn both adjusting screws counterclockwise as far as stop: - The high speed screw (H) is 3/4 turn open. - The low speed screw (L) is 3/4 turn open.
- Start and warm up the engine.
- Adjust idle speed with the idle speed screw (LA) so that the chain does not run.



WARNING! Do not adjust the carburetor by yourself. Contact our company service center for adjusting the carburetor.

Fine Tuning:

A slight correction of the setting of the high speed screw (H) may be necessary if engine power is not satisfactory when operating at high altitude or at sea level.

Rule of thumb: Turn the high speed screw (H) about one quarter of a turn for every 1000 m change in altitude. Conditions for adjustment:

- Carry out the standard setting without disturbing the high speed screw (H).
- Warm up the engine for about 3 minutes.
- Open the throttle wide. At high altitude
- Turn the high speed screw (H) clockwise (leaner), no further than stop, until there is no noticeable increase in engine speed. At sea level
- Turn the high speed screw (H) counterclockwise (richer), no further than stop, until there is no noticeable increase in engine speed. It is possible that maximum engine speed may be reached with the standard setting.

Adjusting Idle Speed:

It is usually necessary to change the setting of the idle speed screw (LA) after every correction to the low speed screw 27 (L).

- Warm up the engine for about 3 minutes. Engine stops while idling
- Turn the idle speed screw (LA) slowly clockwise until the engine runs smoothly - the chain must not rotate.
- Chain rotates when engine is idling
- Turn the idle speed screw (LA) counterclockwise until the chain stops rotating and then turn the screw about another 1/2 to 3/4 turn in the same direction.

Part No	Part Name	Part No	Part Name
BA-08	Fixed Block	BA-30	Right pinion(Big)
BA-09	Gear(Adjust Pin)	BA-31	Bearing 627-Z
BA-10	Screw M6X30(ALLEN)	BA-32	Grease Nipple / Oil Cup
BA-11	BOLT M5X14 (Star)	BA-33	Gear case
BA-12	Connecting oil pipe	BA-34	Left pinion (Small)
BA-13	Protection Block	BA-35	Bearing
BA-14	Screw SPL(Sprocket)	BA-36	Stop ring 26 (Inner)
BA-15	Washer SPL(Sprocket)	BA-37	Stop ring
BA-16	Baffle (Sprocket)	BA-38	Oil Tank Lid Assy
BA-17	Chain wheel / Sprocket	BA-39	N/A
BA-18	Washer/Spacer	BA-40	Gasket (Fuel tank Lid)
BA-19	Screw M4X 12 (Star)	BA-41	N/A
BA-20	Screw M5X 12 (Allen)	BA-42	N/A
BA-21	Oil Pump Assy		

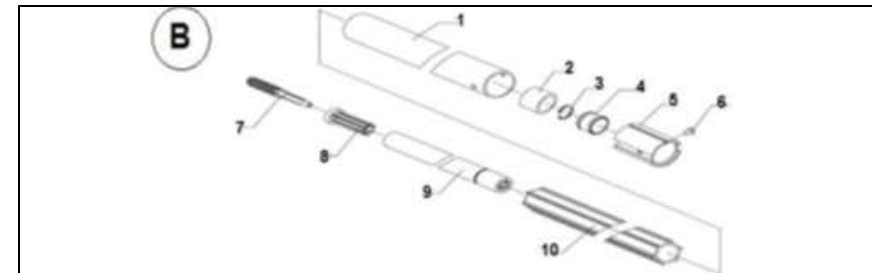

Part No	Part Name	Part No	Part Name
B-B	N/A	BB-06	Rivet 4X8
BB-01	Front Pipe	BB-07	Joint (Front Shaft)
BB-02	Lip Block	BB-08	Rubber Plug (Front Shaft)
BB-03	Stop ring 15	BB-09	Front Shaft
BB-04	Shaft Sleeve (1)	BB-10	Front Shaft

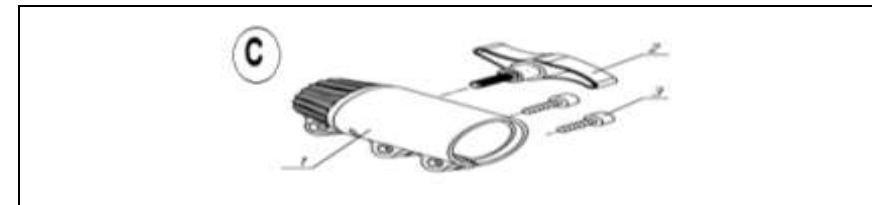

Body Parts Diagram & List-KK-PP2-8627

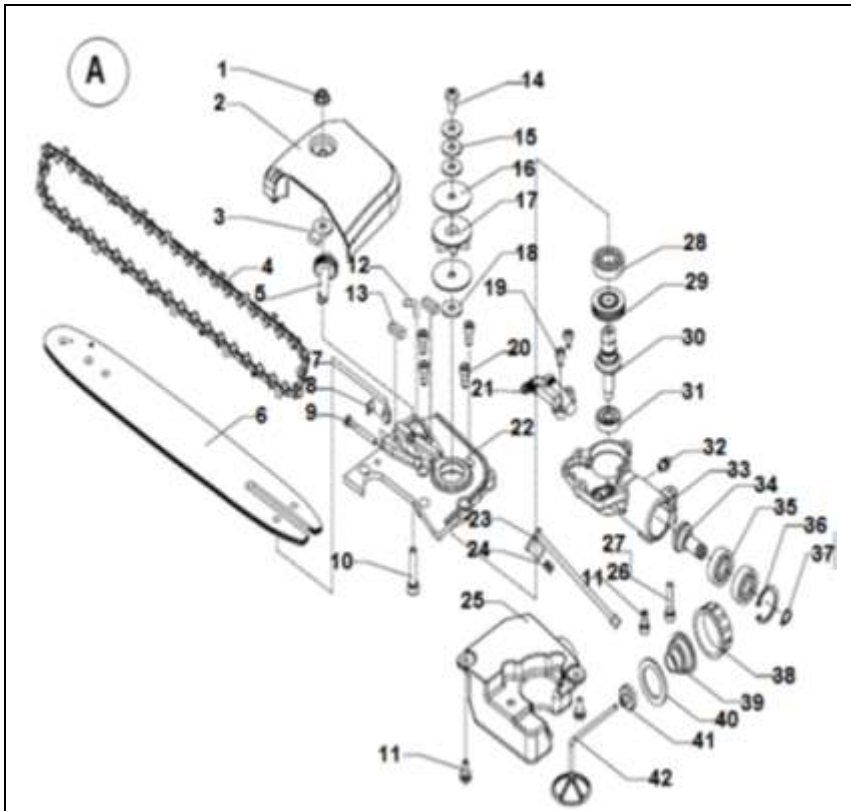

Part No	Part Name	Part No	Part Name
B-A	N/A	BA-22	Box cover (Gear Case)
BA-01	Screw M 6x25 (Allen)	BA-23	Oil Pipe
BA-02	Cover Board Comp	BA-24	Oil Filter
BA-03	Chain wheel adjuster Cover	BA-25	Oil Tank
BA-04	ChainJL9-3	BA-26	Screw M5X25(Allen)
BA-05	Gear(Adjusting)	BA-27	Washer 5 Spring
BA-06	Chain Bar	BA-28	Bearing 6001-2RS/P5
BA-07	Adjust pin	BA-29	Worm

Erratic idling behavior, engine stops even though setting of LA-screw has been corrected, poor acceleration. Idle setting is too lean

- Turn the low speed screw (L) counterclockwise, no further than stop, until the engine runs and accelerates smoothly. Idle setting is too rich
- Turn the low speed screw (L) clockwise, no further than stop, until the engine runs and accelerates smoothly.

⚠ If the chain continues moving when the engine is idling, have your saw machine and repaired by your servicing dealer.

Spark Arresting Screen in Muffler:

If the engine is down on power, check the spark arresting screen in the muffler.

- Wait for the muffler to cool down.
- Move the slide control to STOP.
- Take out the screw (1).
- Take out the screw (2) and remove the shroud (3).
- Take out the screws (4).
- Lift the spark arresting screen (5) and pull it out.
- Clean the spark arresting screen. If the screen is damaged or heavily carbonized, fit a new one.
- Refit the spark arresting screen.
- Insert the screw and tighten it down firmly.
- Fit the shroud.

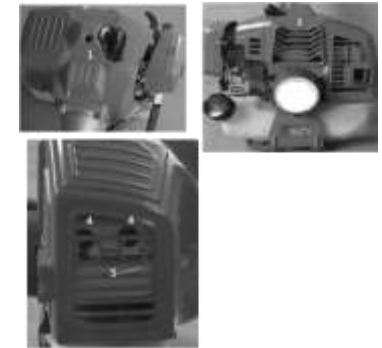

Spark Plug:

If engine is down on power, difficult to start or runs poorly at idling speed, first check the spark plug. Fit a new spark plug after approx. 100 operating hours or earlier if the electrodes are badly eroded. Wrong fuel mix (too much engine oil in the petrol), a dirty air filter and unfavorable running conditions (mostly at throttle part etc.) affect the condition of the spark plug. These factors cause deposits to form on the insulator nose which may result in trouble in operation.

Removing the spark plug:

- Move the slide control to STOP.
- Pull off the spark plug boot (1).
- Unscrew the spark plug.



Checking the Spark Plug:

- Clean dirty spark plug.
- Check electrode gap (A) and readjust if necessary - see "Specifications".
- Use only resistor type spark plugs of the approved range. Rectify problems which have caused fouling of spark plug: - Too much oil in fuel mix. - Dirty air filter. - Unfavorable running conditions, e.g. operating at part load.

⚠WARNING! To reduce the risk of fire and burn injury, use only spark plugs authorized by our company. Always press spark plug boot (1) snugly onto spark plug terminal (2) of the proper size. (Note: If terminal has detachable SAE adapter nut, it must be attached.) A loose connection between spark plug 29 boot and ignition wire connector in the boot may create arcing that could ignite combustible fumes and cause a fire. Installing the spark plug: Screw the spark plug (2) into the cylinder and fit the boot (1) (press it down firmly).



Replacing the Starter Rope and Rewind Spring:

Replacing the Starter Rope:

Push the slide control in direction of arrow to STOP. Take out the screws (1). Remove the starter cover (2) from the housing. Ease the nut (3) off the starter post. Remove the rope rotor with washer (4) and pawl (5). Remove the remaining rope from the rotor and starter grip. Tie a simple overhand knot in the new rope and then thread it through the top of the grip and the rope bushing (6). Thread the rope through the rotor and secure it with a simple overhand knot. Coat the rope rotor bearing bore with non-resinous oil. Slip the rotor over the starter post - turn it back and forth to engage the anchor loop of the rewind spring. Refit the pawl (5) in the rotor. Fit the washer (4) on the starter post.



Part No	Part Name	Part No	Part Name
E-01	Screw(Air Filter)	E-39	Ball Bearing 6001/P6
E-02	Air Cleaner Outside Cover	E-40	Gasket Crank Case
E-03	Air Cleaner Sponge	E-41	Crank Case (Big)
E-04	Baffle (Big)	E-42	Pin 4 H8x10 (Fan Cover)
E-05	Screw M5x60 (Allen)	E-43	Screw M4x20 (Allen)
E-06	Screw M5x12 (Allen)	E-44	Oil Seal (Crank Shaft)
E-07	Baffle (Small)	E-45	Fly Wheel
E-08	Air Cleaner Inside Cover	E-46	Nut M8 (Flanged)
E-09	Carburetor	E-47	Ignition Coil
E-10	Gasket (Carburetor)	E-48	Screw M5x20 (Allen)
E-11	Screw M5x25 (Allen)	E-49	Fan Cover
E-12	Pipe (Breather)	E-50	Screw M5x18 (Allen)
E-13	Insulator	E-51	Washer-B
E-14	Gasket (Insulator)	E-52	Clutch Shoe Assy
E-15	Reed Valve	E-53	Washer -A
E-16	Screw M5x14 (Allen)	E-54	Clutch Bolt
E-17	Gasket (Guide Cover)	E-55	Petrol Filter
E-18	Guide Cover Assy	E-56	Fuel Pipe Grommet
E-19	Screw M5x18 (Allen)	E-57	Fuel Pipe (Big)
E-20	Cylinder	E-58	Fuel Pipe (Small)
E-21	Spark Plug	E-59	Fuel Tank
E-22	Gasket (Cylinder)	E-60	Screw M5x16 (Allen)
E-23	Piston Ring	E-61	N/A
E-24	Piston	E-62	Fuel Tank Lid Assy
E-25	Gasket (Muffler)	E-63	Gasket (Fuel Tank Lid)
E-26	Muffler	E-64	Buy # 62
E-27	Screw M5x65 (Allen)	E-65	
E-28	Screw M4x20 (Allen)	E-66	
E-29	Starter Assy	E-67	
E-30	Start Reel	E-68	Starter Cover
E-31	Crank Case (Small)	E-69	Recoil Spring
E-32	Piston Pin Circlip	E-70	Rope Reel
E-33	Piston Pin	E-71	Ratchet Spring
E-34	Needle Bearing (Piston Pin)	E-72	Ratchet Starter
E-35	Pin 4 H8x10 Crankcase)	E-73	Screw -Ratchet
E-36	Crank Shaft Assy	E-74	Starter Rope
E-37	Clap Board	E-75	Starter Handle
E-38	Screw M5x12 (Allen)		

Engine Parts Diagram & List-KK-PP2-8627

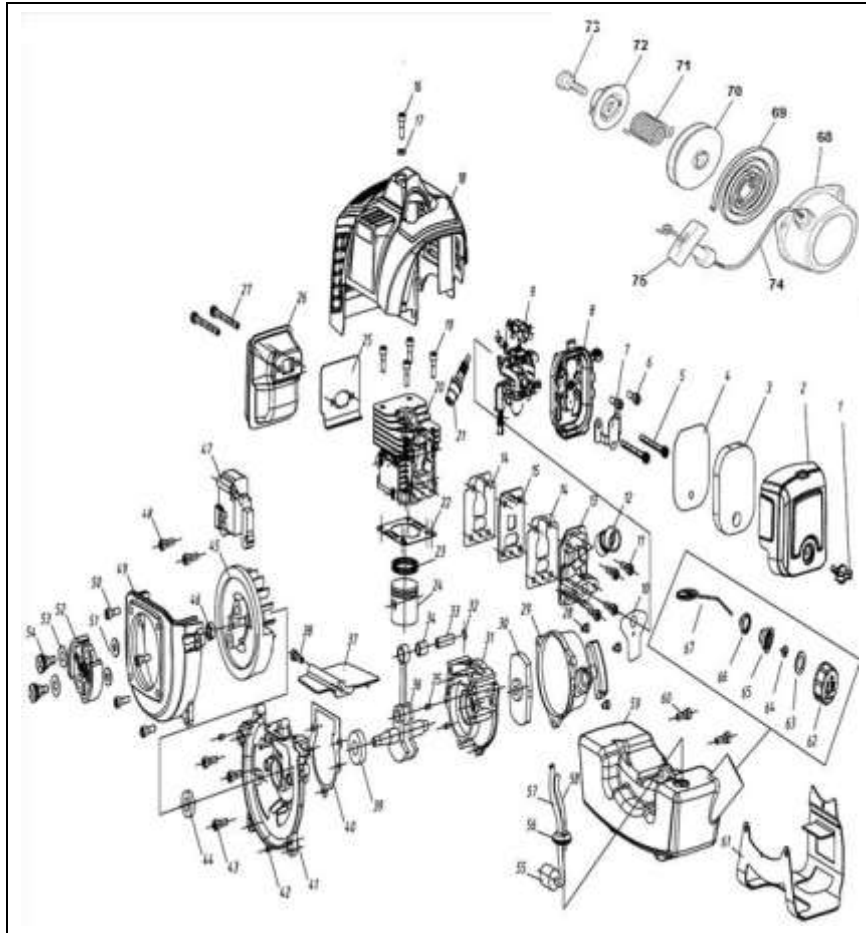

Use a screwdriver or suitable pliers to fit the spring clip (3) on the starter post and over the pawl's peg - the spring clip must point counterclockwise - as shown in the illustration.

Refer to "Tensioning the Rewind Spring".

Replacing a broken rewind spring:

- Remove the rope rotor as described in chapter on "Replacing the starter rope".
- Remove the spring housing and pieces of spring.
- Lubricate the new spring with a few drops of non-resinous oil.
- Position the new spring housing, bottom plate facing up, against the cutouts (arrows).
- Push the spring housing into the starter cover.
- Reinstall the rope rotor - then go to "Tensioning the Rewind Spring".
- If the spring pops out of the spring housing and uncoils: Refit it counterclockwise, starting outside and working inwards.

⚠ The bits of spring may still be under tension and could fly apart when you take them out of the housing. To reduce the risk of injury, wear face protection and work gloves.

Tensioning the rewind spring:

- Make a loop in the unwound starter rope and use it to turn the rope rotor six full revolutions in the direction of the arrow.
- Hold the rotor steady. Pull out and straighten the twisted rope.
- Let go of the rotor.
- Release the rope slowly so that it winds onto the rotor. The starter grip must locate firmly in the rope bushing. If the grip droops to one side: Add one more turn on the rope rotor to increase spring tension.
- When the starter rope is fully extended it must still be possible to rotate the rotor another half turn. If this is not the case, the spring is over tensioned and could break.
- Take one turn of the rope off the rotor.
- Fit the starter cover on the housing.
- Tighten down the screws firmly.

Storage and Transportation

For periods of 3 months or longer

- Drain and clean the fuel tank in a well ventilated area.
- Dispose of fuel properly in accordance with local environmental requirements.
- Run the engine until the carburetor is dry - this helps prevent the carburetor diaphragms sticking together.
- Remove the saw chain and guide bar, clean them and spray with corrosion inhibiting oil.
- Thoroughly clean the machine - pay special attention to the cylinder fins and air filter.
- If you use a biological chain and bar lubricant, completely fill the chain oil tank.
- Transportation guard the machine in a dry, high or locked location, out of the reach of children and other unauthorized persons.

Checking and Replacing the Chain Sprocket

Remove the chain sprocket cover, chain and guide bar.

Replace the chain sprocket

- After using two saw chains or sooner
- If the wear marks (a) are deeper than 0.02 in (0.5 mm) since this would reduce the life of the chain. Use a gauge (special accessory) to check the depth of the wear marks. It is best to use two saw chains in rotation with one sprocket.



We recommend the use of original KisanKraft chain sprockets. The chain sprocket is driven via a friction clutch. Have the chain sprocket replaced by a servicing dealer. We recommend that you have servicing and repair work carried out exclusively by an authorized dealer or KisanKraft service center.

Maintaining and Sharpening the Saw Chain

Cutting effortlessly with a correctly sharpened chain

A properly sharpened chain slices through wood effortlessly and requires very little feed pressure. Do not work with a dull or damaged chain as it will increase the physical effort required, produce unsatisfactory results and a higher rate of wear.

- Clean the chain.
- Check the chain for cracks in the links and damaged
- Replace any damaged or worn parts of the chain and match the new parts to the shape and size of the original parts. Carbide-tipped saw chains are particularly wear resistant. KisanKraft recommends you have your chain sharpened by our servicing dealer. The saw chain cannot be locked in place on the guide bar. Therefore, it is best to remove the chain from the bar and resharpen it on a workshop sharpening tool.



The chain pitch (a) is marked on the new depth gauge end of each cutter

Mark (a)	Chain pitch
P, PM or 6	3/8" P (9.32 mm)
1/4 or 1	1/4" (6.35mm)



A-Filling angle
B-Side plate angle

It is absolutely essential to comply with the angles and dimensions specified below. If the saw chain is incorrectly sharpened – and in particular if the depth gauge is set too low – there is an increased risk of kickback, with resulting risk of injury. Use only special saw chain sharpening files. Other files have the wrong shape and cut. Select file diameter according to chain pitch – see table "Sharpening Tools". You must observe certain angles when re sharpening the chain cutter

Problem	Probable cause	Action to be taken
Too much exhaust gas/fuel dust	Carburetor mixed fuel adjustment error	Adjust carburetor by authorized service personnel
	Fuel mix error	Use 2-stroke mixed fuel in 40:1 mixture ratio

Technical Specifications

Main unit	Remote type	Automatic centrifugal clutch
	Idle speed/clutch speed(min-1)	4200±350 RPM
	Reduction ratio	18:17
	Length of main pipe section(mm)	2900—4250
	Weight when dry(kg)	8.3
Engine	Type	Air-cooled; 2 cycle; vertical; piston valve; petrol
	Displacement(cm ³)	27 cc
	Max Power(kW)	0.75(1hp)
	Rated / Max RPM	7500 RPM
	Maximum output(kW/min ⁻¹)	0.70/7500
	Carburetor	Diaphragm-type
	Ignition	Non-contact electronic ignition
	Starting method	Recoil type
	Fuel used	Petrol mixed with lubricating oil(ratio of 40:1)
	Fuel tank capacity(l)	0.7
Cutting Attachment	Dry weight(kg)	3.1
	Fuel Consumption	600ml/hr
	Cutting length	255
	Nose sprocket	7-teeth
	Oil tank capacity(l)	0.2
	Length (m)	2.9-4.25
	Saw size (cm)	25.4(10 inches)
Drive shaft (mm)	8mm	

Technical data is subject to change without prior notice.

The following intervals apply to normal operating conditions only. If your daily workingtime is longer or operating conditions are difficult (very dusty work area, etc.) shorten the specified intervals accordingly.

		before starting work	after finishing work or daily	after each refueling stop	daily maintenance	weekly	monthly	every 12 months	if problem	if damaged	if required
Guide bar	Check (wear, damage)	x									
	Clean and trim over					x			x		
	Deburr					x					
Chain sprocket	Replace								x	x	
	Check				x	x					
Safety labels	Have replaced by dealer(s)										x
	Remove									x	

NOTE: Daily maintenance, including the checking for loose fasteners, fuel leaks and damaged parts (e.g. cracks in the saw blade).

Troubleshooting

Problem	Probable cause	Action to be taken
Engine does not start.	Start sequence error	Note specification about start machine in this operation instruction.
	Carburetor mixed fuel adjustment error	Adjust carburetor by special repair shop
	Carbon deposit in spark plug	Clean, adjust or replace spark plug
	Fuel filter jam	Replace or clean fuel filter
Engine has started, but the machine does not run in full power.	Choke level position error	Adjust choke level to "Run" position.
	Air filter is dirty	Clean, adjust or replace spark plug
	Carburetor mixed fuel adjustment error	Adjust carburetor by authorized service personnel
Engine trembles and stop.	Carburetor mixed fuel adjustment error	Adjust carburetor by authorized service personnel
	Carbon deposit in spark plug	Clean, adjust or replace spark plug
No power when loading.	Carburetor mixed fuel adjustment error	Adjust carburetor by authorized service personnel

Cutter shapes: Micro = Semi-chisel
The specified angles A and B are obtained automatically if the recommended files or sharpening tools and correct settings are used. The angles must be the same on all cutters. If the angles are uneven: Chain will run roughly, not in a straight line, wear quickly and finally break. As these requirements can be met only after sufficient and constant practice:

- Use a file holder: A file holder must be used for manual re sharpening. The correct filing angles are marked on the file holder.

For checking angles

Use a filing gauge. This is a universal tool for checking the filing and side plate angles, depth gauge setting, cutter length and groove depth. It also cleans the guide bar groove and oil inlet holes.

For checking angles

- Select sharpening tools according to chain pitch.
- If you use an FG 2, HOS or USG sharpener: Remove the chain from the bar and sharpen according to the instructions supplied with the tool.
- Clamp the bar in a vise if necessary.
- Sharpen the chain frequently, take away as little metal as possible - two or three strokes of the file are usually enough.
- Hold the file horizontally (at a right angle to the side of the guide bar) and file according to the angles marked on the file holder. Rest the file holder on the top plate and depth gauge.
- Always file from the inside to the outside of the cutter.
- The file only sharpens on the forward stroke - lift the file off the cutter on the backstroke.
- Avoid touching the tie straps and drive links with the file.
- Rotate the file at regular intervals while filing to avoid one-sided wear.
- Use a piece of hardwood to remove burrs from the cutting edge.
- Check angles with the filing gauge. All cutters must be the same length.

If the cutters are not the same length, they will have different heights. This makes the chain run roughly and can cause it to break.

Find the shortest cutter and then file all other cutters back to the same length. It is best to have this work done in the workshop on an electric grinder.

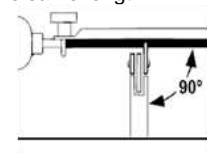
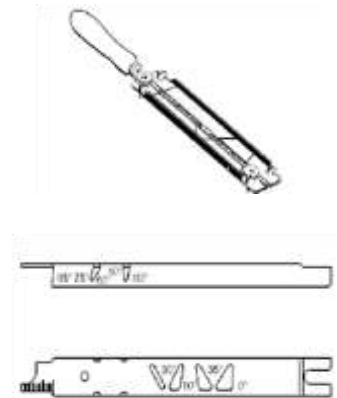

Depth gauge setting

The depth gauge determines the height at which the cutter enters the wood and thus the thickness of the chip removed. (a-Specified distance or setting between depth gauge and cutting edge.) This setting may be increased by 0.2 mm (0.008 in.) for cutting softwood in the mild weather season – no frost.

Chain pitch	Depth gauge setting
3/8" (9.32mm)	0.026" (0.65mm)
1/4" (6.35mm)	0.026" (0.35mm)

Lowering depth gauges

- The depth gauge setting is reduced when the chain is sharpened.
- Use a filing gauge to check the setting every time you sharpen the chain.
- Place a filing gauge (1) that matches the chain pitch on the chain and press it against the cutter – if the depth gauge projects from the filing gauge, the depth gauge has to be lowered.
- File down the depth gauge until it is level with the filing gauge.
- File the top of the depth gauge parallel to the stamped service marking (see arrow) – but do not lower the highest point of the depth gauge in this process. Place the filing gauge on the chain – the highest point of the depth gauge must be level with the filing gauge.

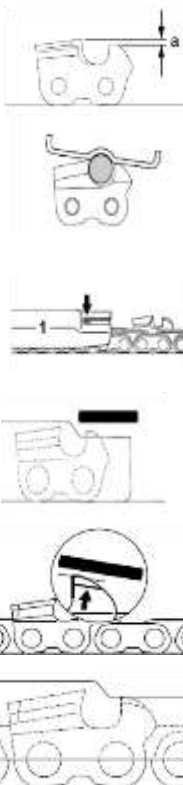

⚠ The kickback tendency of the machine is increased if the depth gauges are too low. PMC3, PMMC3

⚠ The upper part of the humped drive link (with service marking) is lowered along with the depth gauge.

- After sharpening, clean the chain thoroughly, remove filings or grinding dust – lubricate the chain thoroughly.
- Before a long out-of-service period, clean the chain and store it in a well-oiled condition

⚠ The other parts of the humped drive link must not be filed since this may increase the kickback tendency of the power tool.

WARNING!

You must use the saw chain and guide bar, which we are recommended. If you use non approved cutting attachments (saw chain and guide bar), that maybe cause risk of injury.

Inspections and Maintenance

Fuel pickup body in tank:

Have the pickup body in the fuel tank replaced every year. KisanKraft recommends that you have servicing and repair work carried out exclusively by our servicing centers.

Maintenance and Care:

The following intervals apply to normal operating conditions only. If your daily workingtime is longer or operating conditions are difficult (very dusty work area, etc.), shorten the specified intervals accordingly.		work before starting	refueling stop after finishing work or daily	after each	daily maintenance	weekly	monthly	every 12 months	if problem	if damaged	if required
Complete machine	Visual inspection (condition, leaks) Clean	x	x	x							
Control handle	Check operation	x		x							
Air filter	Clean Replace								x	x	x
Pickup body in fuel tank	Check Replace				x			x	x	x	x
Fuel tank	Clean				x				x		x
Carburetor	Check idle adjustment – chain must not rotate Readjust idle	x		x							x
Spark plug	Adjust electrode gap Replace after every 100 operating hours		x						x		
Cooling inlets	Visual inspection Clean										x

The following intervals apply to normal operating conditions only. If your daily workingtime is longer or operating conditions are difficult (very dusty work area, etc.), shorten the specified intervals accordingly.		work before starting	refueling stop after finishing work or daily	after each	daily maintenance	weekly	monthly	every 12 months	if problem	if damaged	if required
Valve clearance	Check and, if necessary, have adjusted by dealer after first 138 hours operation!										x
Combustion chamber	Decoke after first 138 hours of operation, then every 150 hours of operation.										x
Spark arresting screen in muffler	Check Clean or replace		x						x	x	x
All accessible screws and nuts (not adjusting screws)	Tighten										x
Antivibration elements	Check Have replaced by dealer	x							x		x
	Inspect, also check sharpness	x		x							
	Check chain tension	x		x							
	Sharpen										x
Chain lubrication	Check	x			x						