



Wide Range of Products for Every Need



For more information give **MISSED CALL: 07676065555**



Many of our products have BIS: ISI certification.



User Manual



FB - CSP - 8663

All 'FarmBoy' products are sold without any warranty or guarantee. Please satisfy yourself before buying this product. No returns, exchanges or refunds allowed.

Note: The purchase is not contingent upon a product demonstration. The purchaser shall satisfy himself with the product, including any product demonstration or verification of any function, before buying. KisanKraft Limited or its authorized dealers, including online sellers, shall not be liable to give any on-site demonstration after purchase of any of the product.

KisanKraft Limited

(Formerly known as KisanKraft Machine Tools Pvt. Ltd)

Sri Huchhanna Tower, #4, 1st Main, 7-A Cross, Maruthi Layout, Dasarahalli, HAF Post, Hebbal, Bangalore 560024, Karnataka, INDIA

- ◆ Bangalore (HO) ◆ Ahmedabad ◆ Bhopal ◆ Bhubaneswar ◆ Coimbatore ◆
 ◆ Guwahati ◆ Shimla ◆ Hubli ◆ Hyderabad ◆ Jaipur ◆
 ◆ Karnal ◆ Kolkata ◆ Lucknow ◆ Nagpur ◆ Patna ◆ Pune ◆ Raipur ◆

CONTENTS

Before Getting Started3

Safety Symbols3

Safety Precautions5

For Safe Operation8

Installing Guide Bar and Saw Chain12

Fuel and Chain Oil14

Operating the Engine15

Sawing19

Maintenance21

Troubleshooting25

Technical Specification25

KisanKraft has a large range of products to serve the farmers. A list of our products is given below:

<p>Brush Cutters and Accessories</p> <ul style="list-style-type: none"> Brush Cutter/Power Weeder Backpack Brush Cutter Tea Pruner Pole pruner with Engine Reaper Attachment Blades-Circular Blades (2 &3 points) Baffle Nylon Rope Tap & Go <p>Chainsaws</p> <ul style="list-style-type: none"> Petrol Chainsaw Electric Chainsaw Chain Sharpening Machine <p>Engines and Water Pumps</p> <ul style="list-style-type: none"> Engine –Diesel-(Horizontal) Engine –Diesel(Vertical) Engine-Kerosene Water Pump with Petrol Engine Water Pump with Kerosene Engine Water Pump with Diesel Engine <p>Hand Tools</p> <ul style="list-style-type: none"> Secateurs Folding Saw Garden Rake Garden Shovel Hedge Shear Lopper Telescopic Hedge Shear Telescopic Lopping Shear Tree Pruner Telescopic Steel Pipe & Fruit Picker Bag Sheep Shear <p>Garden Tools</p> <ul style="list-style-type: none"> Electric Pressure Washer Hedge Trimmer Lawn Mower (Electric, Petrol & Manual) Leaf Blower 	<p>Cultivators and Accessories</p> <ul style="list-style-type: none"> Petrol and Diesel <p>Sprayers and Accessories</p> <ul style="list-style-type: none"> Battery Sprayer Portable Power Sprayer Trolley Sprayer Manual Knapsack Sprayer Manual Pressure Sprayer Rose Cans Hose Crimping Machine HTP Sprayer HTP Delivery Hose HTP Hose Reel HTP Stand HTP Gun / Lance(Brass Rod) Knapsack Power Sprayer Mister / Duster / Granuel Spreader HTP Sprayer Set with Diesel Engine HTP Sprayer Set with Kerosene Engine Fogging Machine <p>Milking Machine</p> <ul style="list-style-type: none"> Wood Shredder Fodder Ensiling Chaff Cutter Fodder Grinder Chaff Cutter Fodder Mini Chaff Cutter <p>Harvester</p> <ul style="list-style-type: none"> Maize Sheller Maize Sheller + Dehusker Maize Combine Harvester Onion Digger Carlotti Italy Tea Leaf Harvester Sugarcane Combine Harvester Sugarcane Leaf Stripper <p>Transplanter and Post Hole Digger</p> <ul style="list-style-type: none"> Paddy Transplanter (2 & 8 Rows) Transplanter-Vegetable & Tobacco Post Hole Digger(4” to 14”Augers)
---	--

Particulars	Details	
Engine speed	10000 min ⁻¹	
Engine idling speed	3000±300 min ⁻¹	
Maximum chain speed	19.3 m/s	
Spark plug	BOSCH L7T	L7T
Carburetor	Diaphragm type	
Volume of fuel tank	550ml	
Petrol and oil mix ratio	Petrol 25: oil 1	
Volume of oil tank	260ml	
Oil feeding system	Automatic pump with adjuster	
Guide Bar	51 cms (20")	46cm(18")
Saw Chain	20", 325.058*76DL	18",325.058*72DL
Chain pitch	8.25 mm	
Chain gauge	0.058"	
Sprocket	7 Teeth x 8.255 mm	
G.W /N.W	8.4 kg/ 7.4 kg	7.8 kg/6.8 kg
Guaranteed sound power level, L _{WA} (2000/14/EC)	L _{WA} : 117 dB(A)	
Tested sound pressure level, L _{PA} (2000/14/EC)	L _{PA} : 102 dB(A), k=3 dB(A)	
Vibration at Front Handle	A front_hv, eq: 9.41 m/s ² , k=1.5 m/s ²	
Vibration at Rear Handle	A rear_hv, eq: 8.80 m/s ² , k=1.5 m/s ²	
Fuel consumption at max. engine power	1.18 kg/h	

NOTE: Specifications are subject to change without notice.

Before Getting Started

The instructions contained in WARNING within this manual marked with a symbol  concern critical points which must be taken into consideration to prevent possible serious bodily injury and for this reason you are requested to read all such instructions carefully and follow them without fail. After reading, preserve this manual for future reference.

Safety Symbols



This mark indicates instructions which **must** be followed in order to prevent accidents which could lead to serious bodily injury or death.

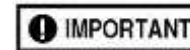











This indicates instructions which must be followed else may lead to mechanical failure, breakdown, or damage.



This indicates hints or directions to use the product.

Warning Labels on the Machine

	Read, understand and follow all warnings.		Keep away from fire
	Read the instruction manual completely and carefully before using the power tool.		Pull to start the engine
	Wear head, eye and ear protection.		The port to refuel the "MIX FUEL"
	Warning! Danger of kickback.		The port to refuel the "OIL"
	Use the chain saw with two hands.		Press the primer bulb several times

	Wear safety footwear		Choke position
	Wear protective gloves		The guaranteed noise level
	With this symbol the manufacturer confirms that this tool is in accordance with applicable European directives.		With this symbol the manufacturer confirms that this tool is in accordance with applicable European directives.





IMPORTANT

If warning seals peel off or become soiled and impossible to read, you should contact the dealer from which you purchased the product to order new seals and affix the new seal(s) in the required location(s).

WARNING

Never remodel the product. We won't warrant the machine, if you use the remodeled product or you don't observe the proper usage written in the manual.

Symbols on the Machine

Symbol	Position	Description
	Fuel Tank Cap	The port to refuel the 'MIX PETROL'
	Oil Cap	The port to refuel the 'CHAIN OIL'
	Rear (back) left of the unit	Setting the switch to the "I" position, the engine starts. Setting the switch to the "O" position, the engine stops immediately.
	Rear (back) right of the unit	Choke will close when pulling the choke knob

Troubleshooting

Case 1. Starting failure

⚠ WARNING

Make sure the icing prevention system is not working.

- | | | |
|------|--|---|
| i. | Check fuel for water or substandard mixture. | Replace with proper fuel |
| ii. | Check for engine flooding. | Remove and dry the spark plug. Then pull the starter again with no choke. |
| iii. | Check spark ignition | Check fuel for water or substandard |

Case 2. Lack of power / Poor acceleration / Rough idling

- | | | |
|------|--|--------------------------------------|
| i. | Check fuel for water or substandard mixture. | Replace with proper fuel. |
| ii. | Check air filter and fuel filter for clogging. | Clean the air filter and fuel filter |
| iii. | Check carburetor for inadequate adjustment. | Readjust speed needles. |

Case 3. Oil does not come out

- | | | |
|-----|---|---------------------------------|
| i. | Check oil for substandard quality. | Replace the oil |
| ii. | Check oil passage and ports for clogging. | Clean the oil passage and ports |

If the unit seems to need further service, please consult your authorized dealer

Technical Specification

Particulars	Details	
Chain saw Model	FB-CSP-8663	FB-CSP-8658
Engine type	Air-cooled, 2-stroke	
Equipment mobility	Hand-held	
Engine displacement	61.5 cc	52 cc
Rated power / rpm	2.4 kW(3.2 hp) / 8500	2.1kW(2.8hp)/8000

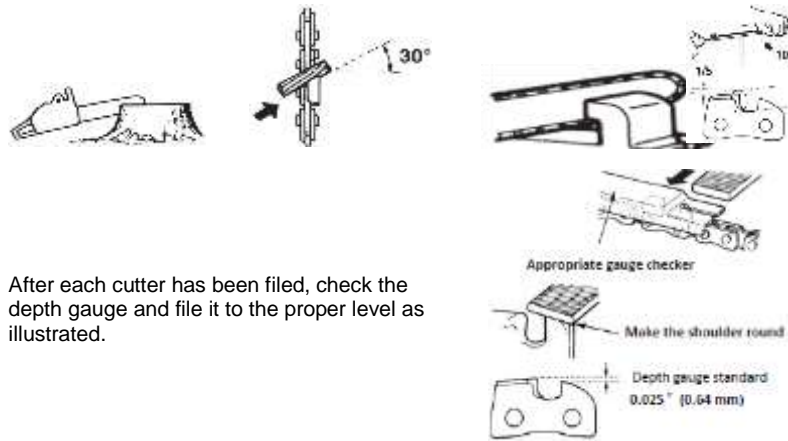

After each cutter has been filed, check the depth gauge and file it to the proper level as illustrated.

⚠ WARNING

Be sure to round off the front edge to reduce the chance of kickback or tie-strap breakage.

Make sure every cutter has the same length and edge angles as illustrated.

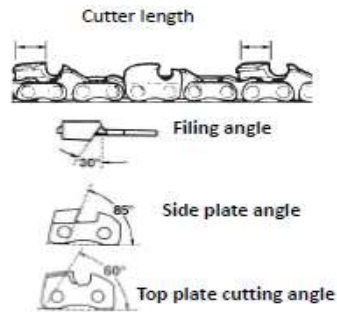

Guide Bar

Reverse the bar occasionally to prevent partial wear.

The bar rail should always be square. Check for wear of the bar rail. Apply a ruler to the bar and the outside of a cutter. If a gap is observed between them, the rail is normal. Otherwise, the bar rail is worn. Such a bar needs to be corrected or replaced.

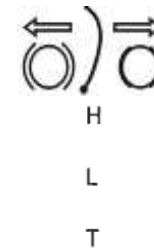
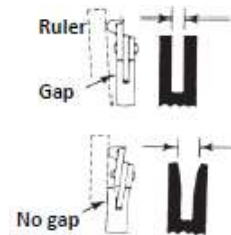

Front of the chain cover

Left side of the rear handle

Shows the directions that the chain brake is released (white arrow) and activated (black arrow)

The screw under the "H" stamp is the High-speed adjustment screw.

The screw under the "L" stamp is the Slow-speed adjustment screw.

The screw at the left of the "T" stamp is the idle adjustment screw.

Safety Precautions

⚠ WARNING - Read Before Operation

A chainsaw is a high-speed, fast cutting power tool and as a result special safety precautions must be taken to reduce the risk of personal injury.

■ Safety Precaution

Please read this manual carefully prior to operating the chain saw. It contains important safety, maintenance and operating instructions. Read these instructions thoroughly even if you are already familiar with chainsaw use.

This product should not be used for any other purpose than described. National regulations can restrict the use of the product.

■ Operator Safety

- Do not operate the chainsaw when you are tired, ill or under the influence of medication, alcohol or drugs. Do not operate the saw if you are fatigued.
- Always wear a safety face shield or goggles.
- Always wear safety protective equipment such as Angus fitting clothing (jacket, trousers) gloves, boots with steel toecaps and non-slip soles. Chainsaw chaps add a layer of safety. Do not wear short, loose clothing such as scarves, jewelry, sandals, or go barefoot. Loose clothing may become tangled in branches or the chainsaw.
- Wear hearing protection. Hearing damage is cumulative.
- Wear non-slip, heavy-duty work gloves to improve your grip on the chainsaw handles. Keep chainsaw handles free of oil and fuel.
- Never let a minor or inexperienced person operate the chainsaw. Bystanders, especially children and animals should be kept out of the area where the chainsaw is in use.
- Never start or run the chainsaw in an enclosed area. The exhaust fumes contain Carbon.
- Keep hands away from the chain cutter. Do not grab or hold the chainsaw by the chain.

- When the chainsaw is turned off, make sure the chain has stopped before placing the unit down.
- Take a break if you have used the chainsaw for a prolonged period of time. Long-term exposure to vibration can result in white-finger disease, a loss of sensation in the hands and the inability to feel and regulate temperature.
- Obey all the local regulations of the cutting area or municipality.

■ Unit/Tool Safety

- Inspect the chainsaw carefully before each use. Replace any damaged parts before use. Check for fuel leaks and tighten any loose fasteners.
- Never modify the chainsaw and use only approved replacement parts for repair work.
- Check chain tension before each use and in between fueling breaks. The chain will lengthen with use especially during the running-in period. A slack chain is dangerous.
- Never let the chain strike anything. If the chain makes contact, stop the chainsaw and inspect for damage.
- Replace any damaged parts before use.
- Make sure the automatic oiler is working. Keep the oil tank filled with clean chain bar oil. Never let the chain run dry on the bar.
- All chainsaw service, other than the items listed in this manual, should be performed by qualified chainsaw service personnel.

■ Chainsaw Use Safety

- Never transport the chainsaw with the chain moving, even for a few steps. Engage the chain brake. For longer distances, shut off the engine, cover the chain with the chain guard (scabbard) and carry the saw in a horizontal position, keeping the hot muffler away from you and the chain facing backwards.
- Do not use the chainsaw to cut any material other than wood or wood objects.
- When cutting wood sprayed with insecticide, use a NIOSH filter mask for respiratory protection. -Stop the chainsaw engine immediately should children, animals, bystanders or helpers enter the cutting hazard zone.
- Hold the chainsaw firmly with both hands with the thumb firmly locked over the front handle. The chainsaw must be held with the right hand on the rear handle and the left hand on the front handle.
- Never cut using one hand.
- While cutting, maintain a firm and balanced footing. Keep your body balanced and never over-reach.
- Keep the muffler and saw chain away from all parts of the body while the engine is running. Keep the bar/chain below waist level.
- Stand to the side of the saw while cutting, never directly behind it.
- Preplan a safe exit from a falling tree before starting the sawing. -Be alert against a kickback. Never cut with the nose of the bar.

5. Spark plug

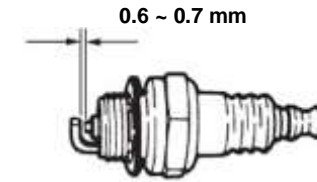

6. Sprocket

Check for cracks and for excessive wear interfering with the chain drive. If the wear is considerable, replace it with new one. Never fit a new chain on a worn sprocket, or a worn chain on a new sprocket.



7. Front and Rear dampers

Replace if adhered part is peeled or crack is observed on the rubber part.

Saw Chain

⚠ WARNING

It is very important for smooth and safe operation to always keep the cutters sharp.

The cutters need to be sharpened when:

1. Sawdust becomes powder-like.
2. You need extra force to saw in.
3. The cut path does not go straight.
4. Vibration increases.
5. Fuel consumption increases.

Cutter Setting Standards:

⚠ WARNING

- Be sure to wear safety gloves.

Before filing:

- Make sure the saw chain is held securely.
- Make sure the engine is stopped.
- Use a round file of proper size for the chain

Place the file on the cutter and push straight forward. Keep the file position as illustrated.

3. Guide bar

When the guide bar is dismantled, remove sawdust in the bar groove and the oiling port. Grease the nose sprocket from the feeding port on the tip of the bar.



4. Others

Check for fuel leakage and loose fastenings and damage to major parts, especially handle joints and guide bar mounting. If any defects are found, make sure to have them repaired before operating the saw again.

Periodical Service Points

1. Cylinder fins

Dust clogging between the cylinder fins will cause overheating of the engine. Periodically check and clean the cylinder fins after removing the air cleaner and the cylinder cover. When installing the cylinder cover, make sure that switch wires and grommets are positioned correctly in place.

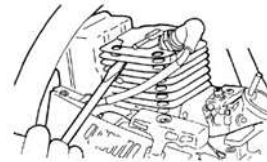

NOTE

Be sure to block the air intake hole.

2. Fuel filter

- Using a wire hook, take out the filter from the filler port.
- Disassemble the filter and wash with gasoline, or replace with a new one if needed.

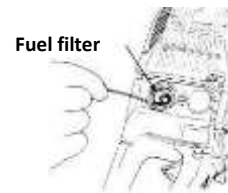

NOTE

- After removing the filter, use a pinch to hold the end of the suction pipe.
- When assembling the filter, take care not to allow filter fibers or dust inside the suction pipe.

3. Oil tank

With a wire hook, take out the oil filter through the filler port and clean in gasoline. When putting the filter back into the tank, make sure that it comes to the front right corner. Also clean off dirt in the tank

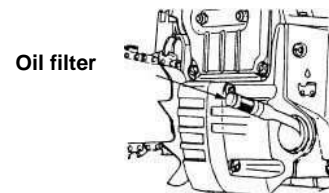

- Only use cutting attachments as listed in the technical data within these instructions. The use of other attachments leads to hazards resulting in personal injuries and damage to property.

■ Fueling Safety

- Mix and pour fuel outdoors in areas free of sparks and flames. Use a container designed for fuel storage.
- Do not smoke or allow smoking near fuel or the chainsaw while in use.
- Wipe up all fuel spills before starting the chainsaw.
- Move 10 feet away from the fuel before starting the chainsaw.
- Stop the engine before removing the fuel tank cap.
- Empty the fuel tank before storing the chainsaw. Store the saw and fuel where fuel vapors cannot reach sparks or open flames appliances or electrical switches/motors.

■ Maintenance Safety

- Maintain the chainsaw according to the recommended schedule listed in the manual.
- Disconnect spark plug before performing maintenance except for carburetor adjustments.
- Keep bystanders away from the saw while adjusting carburetor.
- Use only replacement parts authorized for the chainsaw while making repairs or maintaining the saw.
- Inspect the product before each use, after dropping the products or exposing to other impacts to identify significant defects.
- Secure the product during transport to prevent loss of fuel, damage and injury.
- Clean and maintain the product as described in these instructions before storage. Always use guards on saws when storing.
- Attach the transportation cover for the saw during transport and storage.

■ Transport and Storage Safety

- Always carry the saw with the engine stopped, muffler away from the body and chain facing backwards.
- Allow the engine to cool, empty the fuel tank, cover the chain with the scabbard, and secure the saw before storing or transporting in a vehicle.
- Empty the fuel tank before storing the saw. We recommend emptying the fuel tank after each use.
- If fuel is left in tank, store in a position so as to prevent leakage.
- Always to use guide-bar cover during transport and storage.
- Clean the saw prior to storage and maintenance. Store the unit with chain covered and out of reach of children.

For Safe Operation



1. Never operate a chain saw when you are fatigued, ill, or upset, or under the influence of medication that may make you drowsy, or if you are under the influence of alcohol or drugs.



2. Use safety footwear, snug fitting clothing and eye, hearing and head protection devices. Use the vibration-proof glove.

3. Keep the saw chain sharp and the saw, including the AV system, well maintained. A dull chain will increase cutting time, and pressing a dull chain through wood will increase the vibrations transmitted to your hands. A saw with loose components or with damaged or worn AV buffers will also tend to have higher vibration levels.



4. Always use caution when handling fuel. Wipe up all spills and then move the chain saw at least 3 m from the fueling point before starting the engine.



5. Eliminate all sources of sparks or flame (i.e. smoking, open flames, or work that can cause sparks) in the areas where fuel is mixed, poured, or stored.

6. Do not smoke while handling fuel or while operating the chain saw.



7. Do not allow other persons to be near the chain saw when starting or cutting. Keep bystanders and animals out of the work area. Children, pets and bystanders should be a minimum of 10 m away when you start or operate the chain saw.



8. Never start cutting until you have a clear work area, secure footing, and a planned retreat path from the falling tree.

First check to which side the limb is bent. Then make the initial cut from the bent side and finish by sawing from the opposite side.

Pruning of Standing Tree

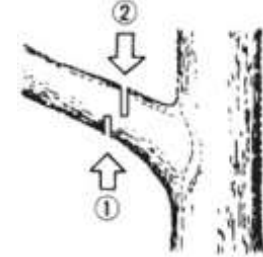

Cut up from the bottom, finish down from the top.

⚠ WARNING

- Be alert to the springing back of a cut limb
- Do not use an unstable foothold or ladder.
- Do not overreach.
- Do not cut above shoulder height.
- Always use both your hands to hold the saw.

Maintenance

⚠ WARNING

Before cleaning, the inspecting or repairing the unit, make sure that engine has stopped and is cool. Disconnect the spark plug to prevent accidental starting.

Maintenance after Each Use

1. Air filter

Dust on the cleaner surface can be removed by tapping a corner of the cleaner against a hard surface. To clean dirt in the meshes, split the cleaner into halves and brush in gasoline. When using compressed air, blow from the inside.



To assemble the cleaner halves, press the rim until it clicks.

📖 NOTE

When installing the main filter, make sure that the grooves on the filter edge are correctly fit with the projections on the cylinder cover.

2. Oiling port

Dismount the guide bar and check the oiling port for clogging.



Felling direction

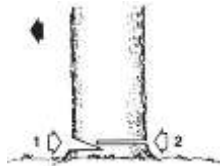

Notch cut

Felling cut

⚠ WARNING

When you fell a tree, be sure to warn neighboring workers of the danger.

Bucking and Limbing

⚠ WARNING

- Always ensure your foothold. Do not stand on the log.
- Be alert to the rolling over of a cut log. Especially when working on a slope, stand on the uphill side of the log.
- Follow the instructions in “For Safe Operation” to avoid kickback of the saw.

Before starting work, check the direction of bending force inside the log to be cut.

Always finish cutting from the opposite side of the bending direction to prevent the guide bar from being caught in the cut.

A log lying off the ground

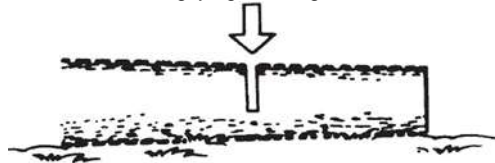

A log hanging off the ground

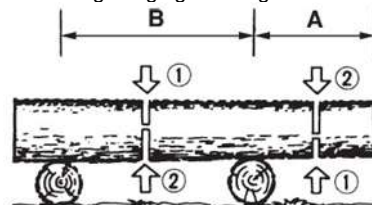

Saw down halfway, then roll the log over and cut from the opposite side.

Cutting the limbs of Fallen Tree

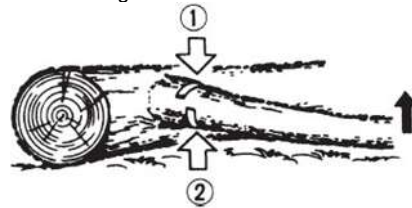

In area A, saw up from the bottom one-third and finish by sawing down from the top. In area B, saw down from the top one-third and finish by sawing up from the bottom.

9. Always hold the chain saw firmly with both hands when the engine is running. Use a firm grip with thumb and fingers encircling the chain saw handles.



10. Keep all parts of your body away from the saw chain when the engine is running.



11. Before you start the engine, make sure the saw chain is not contacting anything.



12. Always carry the chain saw with the engine stopped the guide bar and saw chain to the rear, and the muffler away from your body.



13. Always inspect the chain saw before each use for worn, loose, or dam-aged parts. Never operate a chain saw that is damaged, improperly adjusted, or is not completely and securely assembled. Be sure that the saw chain stops moving when the throttle control trigger is released.

14. All chain saw service, other than the items listed in the Owner's Manual, should be performed by competent chain saw service personnel.



15. Always shut off the engine before setting it down.
16. Use extreme caution when cutting small size brush and saplings because slender material may catch the saw chain and be whipped toward you or pull you off balance.



17. When cutting a limb that is under tension, be alert for spring- back so that you will not be struck when the tension in the wood fibers is released.
18. Never cut in high wind, bad weather, when visibility is poor or in very high or low temperatures. Always



- check the tree for dead branches which could fall during the felling operation.
19. Keep the handles dry, clean and free of oil or fuel mixture
 20. Operate the chain saw only in well ventilated areas. Never start or run the engine inside a closed room or building and potentially explosive atmosphere. Exhaust fumes contain dangerous carbon monoxide.
 21. Do not operate the chain saw in a tree unless specially trained to do so.
 22. Guard against kickback. Kickback is the upward motion of the guide bar which occurs when the saw chain at the nose of the guide bar contacts an object. Kickback can lead to dangerous loss of control of the chain saw.
 23. When transporting your chain saw, make sure the appropriate guide bar scabbard is in place.
 24. Never touch the cover, guide bar, saw chain or nut with bare hands while the engine is in operation or immediately after shutting down the engine. Doing so could result in serious burns because of high temperature.

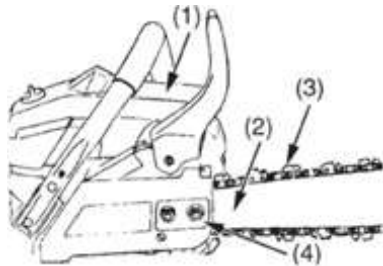

1) Cover (2) Guide bar (3) Saw chain (4) Nut

Sawing

Guard Against Kickback



This saw is equipped with a chain brake that will stop the chain in the event of kickback if operating properly. You must check the chain brake operation before each usage by running the saw at full the throttle for 12 seconds and pushing the front hand guard forward. The chain should stop immediately with the engine at full speed. If the chain is slow to stop or does not stop, replace the brake band and clutch drum before use.

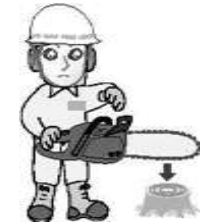

It is extremely important that the chain brake be checked for proper operation before each use and that the chain be sharp in order to maintain the kickback safety level of this saw. Removal of the safety devices, inadequate maintenance, or incorrect replacement of the bar or chain may increase the risk to serious personal injury due to kickback.



Felling a Tree

1. Decide the felling direction considering the wind, lean of the tree, location of heavy branches, ease of completing the task after felling and other factors.
2. While clearing the area around the tree, arrange a good foothold and retreat path.
3. Make a notch cut one-third of the way into the tree on the felling side.
4. Make a felling cut from the opposite side of the notch and at a level slightly higher than the bottom of the notch.

guard toward the front handle till a "click" sound is heard.

⚠️ WARNING

Be sure to confirm brake operation during daily inspection.

How to Confirm:

1. Turn off the engine.
2. Holding the chain saw horizontally, release your hand from the front handle, hit the tip of the guide bar to a stump or a piece of wood, and confirm brake operation. Operating level varies by bar size.

In case the brake is not effective, ask our dealer for inspection and repairs. If the engine keeps rotating at high speed with the brake engaged, the clutch will overheat causing trouble. When the brake engages during operation, immediately release the throttle lever to stop the engine.



Stopping the Engine:

- 1 Release the throttle lever to allow the engine to idle for a few minutes.
- 2 Set the switch to the "O" (STOP) position.



⚠️ WARNING

- Before proceeding to your job, read the section "For Safe Operation". It is recommended to first practice sawing easy logs. This also helps you get accustomed to your unit.
- Always follow the safety regulations. The chain saw must only be used for cutting wood. It is forbidden to cut other types of material.
- Vibrations and kickback vary with different materials and the requirements of the safety regulations would not be respected.
- Do not use the chain saw as a lever for lifting, moving or splitting objects. Do not lock it over fixed stands. It is forbidden to hitch tools or applications to the PTO other than those specified by the manufacturer.
- It is not necessary to force the saw into the cut. Apply only light pressure while running the engine at full throttle.
- When the saw chain is caught in the cut, do not attempt to pull it out by force, but use a wedge or a lever to open the way.



Kickback Safety Precautions for Chain Saw Users



Kickback may occur when the nose or tip of the guide bar touches an object, or when the wood closes in and pinches the saw chain in the cut. Tip contact in some cases may cause a lightning fast reverse reaction, kicking the guide bar up and back towards the operator. Pinching the saw chain along the top of the guide bar may push the guide bar rapidly back towards the operator. Either of these reactions may cause you to lose control of the saw, which could result in serious personal injury.

Do not rely exclusively on the safety devices built into your saw. As a chain saw user you should take several steps to keep cutting jobs free from accident or injury.

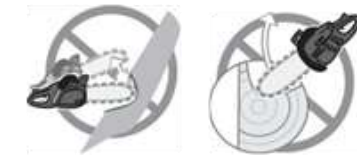

1. With a basic understanding of kick-back you can reduce or eliminate the element of surprise. Sudden surprise contributes to accidents.
2. Keep a good grip on the saw with both hands, the right hand on the rear handle, and the left hand on the front handle, when the engine is running. Use a firm grip with thumbs and fingers encircling the chain saw handles. A firm grip will help you reduce kickback and maintain control of the saw.



3. Make certain that the area in which you are cutting is free from obstructions. Do not let the nose of the guide bar contact a log, branch, or any other obstruction which could be hit while you are operating the saw.



4. Cut at high engine speeds.
5. Do not overreach or cut above shoulder height.
6. Follow the manufacturer's sharpening and maintenance instructions for the saw chain.



- Only use replacement bars and chains specified by the manufacturer or the equivalent.

Worse Effects of Vibration

If you continue to use high-vibration tools these symptoms will probably get worse, for example:

- The numbness in your hands could become permanent and you won't be able to feel things at all;
- You will have difficulty picking up small objects such as screws or nails;
- The vibration white finger could happen more frequently and affect more of your fingers.

For Protecting Your Body from Vibration

Please observe the following matter, in order to protect the health of your body.

- Always use the right tool for each job (to do the job more quickly and expose you to less hand-arm vibration).
- Check tools before using them to make sure they have been properly maintained and repaired to avoid increased vibration caused by faults or general wear.
- Make sure cutting tools are kept sharp so that they remain efficient.
- Reduce the amount of time you use a tool in one go, by doing other jobs in between.
- Avoid gripping or forcing a tool or work piece more than you have to.
- Store tools so that they do not have very cold handles when next used.

Installing Guide Bar and Saw Chain

A standard saw unit package contains the items as illustrated.

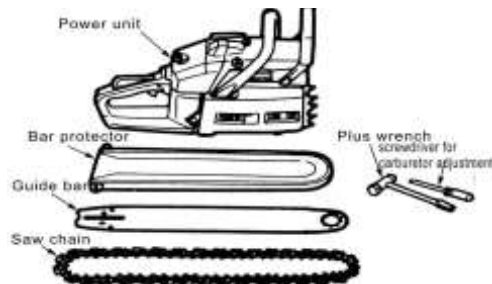

The chain oil flow can be changed by inserting a screw-driver in the hole on bottom of the clutch side. Adjust according to your work conditions.



NOTE

The oil tank should become nearly empty by the time fuel is used up. Be sure to refill the oil tank every time when refueling the saw.

Adjusting the Carburetor

The carburetor on your unit has been factory adjusted, but may require fine tuning due to a change in operating conditions. Before adjusting the carburetor, make sure that the provided air/fuel filters are clean and fresh and the fuel properly mixed. When adjusting, take the following steps:

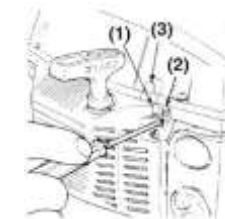

- L needle
- H needle
- Idle adjusting screw

NOTE

Be sure to adjust the carburetor with the bar chain attached.

- H and L needles are restricted within the number of turn as shown below.

H needle	-1/4	-1/4
L needle	-1/4	-1/4
- Start the engine and allow it to warm up in low speed for a few minutes.
- Turn the idle adjusting screw (T) counterclockwise so that the saw chain does not turn. If the idling speed is too slow, turn the screw clockwise.
- Make a test cut and adjust the H needle for best cutting power, not for maximum speed.

Chain Brake

- This machine is equipped with an automatic brake to stop saw chain rotation upon occurrence of kickback during saw cutting. The brake is automatically operated by inertial force, which acts on the weight fitted inside the front guard.
- This brake can also be operated manually with the front guard turned down to the guide bar. To release the brake, pull up the front

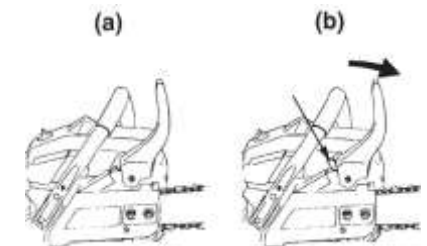

- Set the switch to "I" position

- Pull out the choke knob to the closed position.

NOTE

When restarting immediately after stopping the engine, leave the choke knob at the open position.

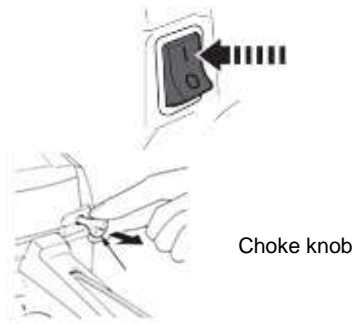

- While holding the saw unit securely on the ground, pull the starter rope vigorously.



WARNING

Do not start the engine while the chain saw hangs in one hand. The saw chain may touch your body. This is very dangerous.

- When engine has ignited first, pull the throttle lever to return the choke knob to the open position and then pull the starter again to start the engine.
- Allow the engine to warm up with the throttle lever pulled slightly

WARNING

Keep clear of the saw chain as it will start rotating upon starting of engine. Checking the Oil Supply

WARNING

Make sure to set up the bar and the chain when checking the oil supply. If not, the rotating parts may be exposed. It is very dangerous.

After starting the engine, run the chain at medium speed and see if chain oil is scattered off as shown in the figure.



Open the box and install the guide bar and the saw chain on the power unit as follows:

WARNING

◆The saw chain has very sharp edges. Use thick protective gloves for safety.

- Pull the guard towards the front handle to check that the chain brake is not engaged.
- Loosen the nuts and remove the chain cover.
- Install the attached spike to the power unit.
- Gear the chain to the sprocket and, while fitting the saw chain around the guide bar, mount the guide bar to the power unit. Adjust the position of chain tensioner nut on the chain cover to the lower hole of guide bar.

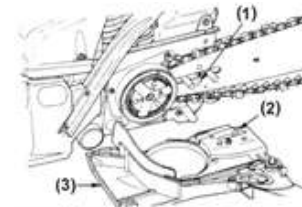

- Hole
- Tensioner nut
- Chain cover

NOTE

Pay attention to the correct direction of the saw chain.

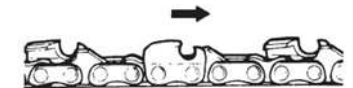

- Fit the chain cover to the power unit and fasten the nuts to finger tightness.
- While holding up the tip of the bar, adjust the chain tension by turning the tensioner screw until the tie straps just touch the bottom side of the bar rail.

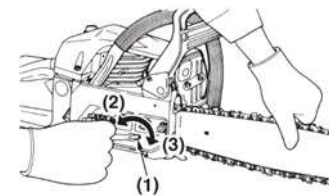

- Tensioner screw
- Loosen
- Tighten

- Tighten the nuts securely with the bar tip held up (12 ~ 15 N.m). Then check the chain for smooth rotation and proper tension while moving it by hand. If necessary, readjust with the chain cover loose.
- Tighten the tensioner screw.



A new chain will expand its length in the beginning of use. Check and readjust the tension frequently as a loose chain can easily derail or cause rapid wear of itself and the guide bar.

Fuel and Chain Oil

■ FUEL

⚠ WARNING

- Petrol is very flammable. Avoid smoking or bringing any flame or sparks near fuel.
- Wipe up all spills before starting the engine.
- Make sure to stop the engine and allow it cool before refueling the unit.
- Keep open flames away from the area where fuel is handled or stored.



❗ IMPORTANT

- Never use oil for 4 cycle engine use or water cooled 2-cycle engine.
- Never use "FUEL WITH NO OIL (PURE PETROL)".
- Never use fuel laced with water.
- Mixed fuels which have been left unused for a period of one month or more may clog the carburetor or result in the engine failing to operate properly. Put remained fuel into an air-tight container and keep it in the dark and cool room.
- Please ask for "mixed petrol for air-cooled 2-cycle engines" at your nearest gas station, or use fuel made by putting unleaded petrol for automobiles and air-cooled 2-cycle engine oil into a mixing container in accordance with the following ratios and then shaking to mix well.

How to Mix Fuel:

1. Measure out the quantities of gasoline and oil to be mixed.
2. Put some of the gasoline into a clean, approved fuel container.
3. Pour in all of the oil and agitate well.
4. Pour in the rest of gasoline and agitate again for at least one minute. As some oils may be difficult to agitate depending on oil ingredients, sufficient agitation is necessary for the engine to last long. Be careful that, if the agitation is insufficient, there is an increased danger of early piston seizing due to abnormally lean mixture.
5. Put a clear indication on the outside of the container to avoid mixing up with gasoline or other containers.
6. Indicate the contents on outside of container for easy identification



**RECOMMENDED MIXING RATIO:
PETROL: OIL = 40:1**

Fueling the Unit:

1. Untwist and remove the fuel cap. Rest the cap on a dustless place.
2. Put fuel into the fuel tank to 80% of the full capacity.
3. Fasten the fuel cap securely and wipe up any fuel spillage around the unit.

⚠ WARNING

1. Select flat and bare ground for fueling.
2. Move at least 10 feet (3 meters) away from the fueling point before starting the engine.
3. Stop the engine before refueling the unit. At that time, be sure to sufficiently agitate the mixed gasoline in the container.
4. In the case of storing the product for a long period of time, clean the fuel tank after rendering it empty. Next, activate the engine and empty the carburetor of the composite fuel.

Chain Oil

Use motor oil SAE #10W-30 all year round or SAE #30 ~ #40 in summer and SAE #20 in winter.



Do not use wasted or regenerated oil that can cause damage to the oil pump.

Operating the Engine

⚠ WARNING

It is very dangerous to run a chainsaw that mounts broken parts or lacks any parts. Before starting engine, make sure that all the parts including bar and chain are installed properly.

Starting the Engine:

1. Fill fuel and chain oil tanks respectively, and tighten the caps securely

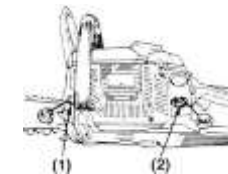

(1) Chain oil
(2) Fuel